



SHENZHEN AVIACONN PRECISION TECHNOLOGY CO. LTD

Web: www.aviaconn.com

Technical email: technical@aviaconn.com

Sales email: sales@aviaconn.com

AEROSPACE-GRADE CONNECTOR





Shenzhen Anknor Technology Co., Ltd. (ANKNOR) is a wholly-owned subsidiary of MOFLON, a global manufacturer of high-end precision rotary connectors. ANKNOR focuses on the research, development, production, and sales of high-precision connector products, committed to providing customized and highly reliable connection solutions for global customers.

MOFLON, with its factory located in Shajing, Shenzhen, employs over 500 people and has an annual sales revenue exceeding 300 million RMB. With a 20,000 square meter high-tech factory, MOFLON is dedicated to high-end manufacturing, driving industry development with high-quality products. Its products are widely exported to developed countries in Europe, America, and Japan, and have entered the European and American aerospace and military industries. MOFLON has established long-term and friendly cooperative relationships with many internationally renowned brands. Over 60% of its products are customized, widely used in robotics, CCTV camera systems, packaging machinery, medical instruments, and automation systems. The company has also obtained ISO 9001, UL, CE, and other relevant certifications.

Leveraging the strong resources of its parent company, ANKNOR can undertake highly demanding and complex special customization needs, continuing the parent company's advantage of over 60% customized product sales. Its products include standard and customized high-precision conductive slip rings and standard and customized industrial connectors, possessing characteristics such as high precision, high stability, and strong adaptability, with performance comparable to international advanced levels.

ANKNOR's products are applied in various high-end fields, including aerospace, marine, military, robotics, automotive, medical instruments, intelligent manufacturing, automation systems, weaponry, railways, oil exploration, wind power generation, and agricultural informatization.

In the future, ANKNOR will use its parent company's technological expertise as a solid foundation, with innovation as its core driving force, to build a benchmark brand in its niche market, creating more valuable connection solutions for global customers and jointly exploring new opportunities in the industry

Office environment



PRECISE

Precise Production Control, High Quality and Efficiency



QUALITY

Rigorous testing ensures product quality

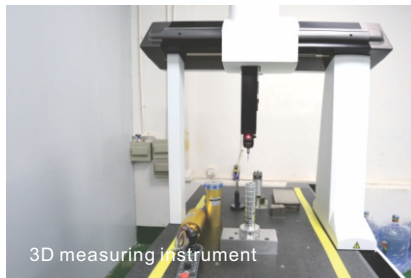
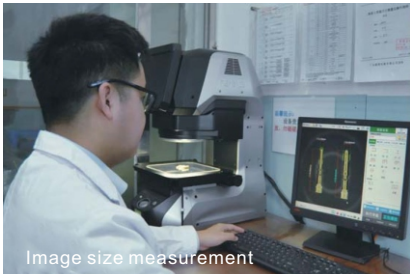



HONOR

Honors and Qualifications



CONTENT

A950 Harsh Environment High-Density Electrical Connector.....	07
GJB599III Series High and Low Frequency Mixed Integrated Marine Environment Electrical Connector.....	25
GJB599III Electrical Connector.....	33
GJB599III Composite Material Electrical Connector.....	39
GJB599 IV Electrical Connector.....	61
GJB599 I Electrical Connector.....	75
GJB599 Rack-Mounted Pneumatic (JYF) Connector.....	103
GJB599 Power Connector.....	109
GJB590 High-Density Miniature (JVS) Connector.....	115
GJB599 Hermetic Electrical Connector.....	120
GJB599 Aerospace-Grade Electrical Connector.....	135

A950 Harsh Environment High-Density Electrical Connector



The pictures are for reference only

A950 Harsh Environment High-Density Electrical Connector

Product Introduction

- The h-end military connector in China.
- Three-head thread connection structure with a unique anti-loosening mechanism.
- Adopts highly reliable hyperbolic spring pin holes.
- Strong salt spray resistance, with aluminum alloy salt spray resistance up to 500 hours.
- 100% anti-misinsertion.
- Excellent EMI/RFI shielding performance.
- Can realize the replacement of RF, differential, and optical fiber contacts in corresponding hole positions to achieve integrated transmission of different signals.
- Contacts adopt the rear-release and rear-pickup mode.
- Termination methods include crimping, welding, and printed board soldering.
- With fireproof shell, aluminum alloy shell, and various coatings.
- Implements the enterprise standard: Q/21EJ950.



Application

- The product is suitable for connection between circuit signals.

Main Technical Performance

[Mechanical Performance]

- Housing: Aluminum alloy, stainless steel
- Plating: W - Aluminum alloy plated with cadmium olive drab;
Z - Aluminum alloy plated with zinc - nickel;
K - Stainless steel passivation
- Vibration:
- Sine: 10 - 2000Hz, 60g
- Random: 10 - 2000Hz, power spectral density is 5g²/Hz at ambient temperature and 1g²/Hz at high temperature
- Shock: 3ms half - sine wave, acceleration peak 300g
- Mechanical Life: 1000 mating cycles

[Mechanical Performance]

Contact Resistance and Rated Current of Contacts:

Contact Specifications	Working Diameter (mm)	Contact Resistance (mΩ)	Contact Resistance (mΩ)
22#	Φ0.76	12.5	12.5
20#	Φ1.00	5	5
16#	Φ1.60	2.5	2.5
12#	Φ2.40	1.5	1.5
10#	Φ3.15	1	1

Contact Matching Wire:

Contact Matching Wire:	Core Wire Cross-Section (mm ²)	Compatible American Wire Gauge (AWG)	Wire (Cable) Outer Diameter (mm)	
			min	max
22#	0.08, 0.13, 0.21, 0.33	28, 26, 24, 22	0.76	1.27
20#	0.21, 0.33, 0.52	24, 22, 20	1.02	2.11
16#	0.52, 0.82, 1.31	20, 18, 16	1.65	2.77
12#	2.08, 3.31	14, 12	2.46	3.61
10#	5.26	10	3.42	4.12

Operating Environment

The product is applied in various military and civilian environments, with performance against humidity, smoke, fungi, rain, and dust. It is particularly suitable for high-vibration and impact environments, such as engine systems.

[Environmental Performance]

- Operating Temperature: Type W, Z: -65°C ~ +175°C; Type K: -65°C ~ +200°C
- Salt Spray Resistance: Type Z: 200h; Type W: 500h; Type K: 1000h
- Damp Heat: According to Method 1002 in GJB1217: 10 cycles of 24 hours
- eachLiquid Resistance: Resistant to various fuels, coolants, and solvents
- Fungus Resistance: According to GJB150.10, test duration 28 days

A950 Harsh Environment High-Density Electrical Connector

- Insulation Resistance: $\geq 5000M\Omega$ at room temperature; $\geq 1000M\Omega$ at high temperature; $\geq 100M\Omega$ in damp heat
- Withstand Voltage: V

Working Grade*	M	I	I	II	N
Sea Level	1300	1800	1800	2300	1000
21336m	350	400	400	500	260

***Note: Different contact arrangements have different working grades. For details, see Contact Arrangement.**

- Electromagnetic Interference Shielding:
At 100MHz-1GHz, the minimum attenuation is 85dB (for types P, W, and Z).
At 1GHz-10GHz, the minimum attenuation is 65dB (for type P), and 50dB (for types W and Z).

[RF Contact Performance]

- 16# Shielded Contacts (Model: Pin—J1216/76-424; Socket—J1216/77-428)
- 12# Shielded Contacts (Model: Pin—J1216/28-211; Socket—J1216/75-416)

Low-level Contact Resistance (Only applicable to internal contacts)

Working Grade*	Maximum Contact Resistance (m Ω)	
	Initial Value	After test
16#	170	204
12#	55	66

Test Current and Voltage Drop:

Contact	Test Current (A)	Voltage Drop (mV)				
		25°C		175°C	200°C	
		Initial	After Test	After Test		
16#	Internal Contact	1	170	204	290	—
12#					—	290
16#	External Contact	12	150	180	255	—
12#					—	255

Withstand Voltage (Between Internal and External Contacts): 750 Vrms at sea level; 250 Vrms at 15240m

- 16# Shielded Contacts (Model: Pin—J1216/76-424; Socket—J1216/77-428)
- 12# Coaxial Contacts (Model: Pin—J1216/102-558; Socket—J1216/103-559)
- Nominal Impedance: 50 Ω
- Operating Frequency: DC0-3GHz
- Low-level Contact Resistance (Only for Internal Contacts): Initial value 55m Ω , 66m Ω after test
- Withstand Voltage: 1000 Vrms at sea level; 250 Vrms at 15240m
- Test Current and Voltage Drop:

Contact	Test Current (A)	Voltage Drop (mV)		
		25°C		94
		Initial	After Test	
Internal Contact	1	55	66	94
External Contact	12	75	90	128

- Voltage Standing Wave Ratio (VSWR):
Within the frequency range of 500MHz~3GHz, the voltage standing wave ratio shall not exceed $1.20 + 0.04f$ (where f is in GHz).
- Insertion Loss: dBmax = $0.11\sqrt{f}$ (where f is in GHz). When measured at 3GHz according to MIL-C-39012, the insertion loss shall not exceed 0.20dB.

A950 Harsh Environment High-Density Electrical Connector

12# Coaxial Contact (40GHz) (Model: Pin—J1216/102-558C; Socket—J1216/103-559C)

- Nominal Impedance: 50Ω
- Operating Frequency: DC0~40GHz
- Voltage Standing Wave Ratio (VSWR): 0~18GHz: ≤1.3; 18~40GHz: ≤1.7
- Withstand Voltage (Between Center Conductor and Outer Conductor): 500 Vrms
- Vibration: 10~2000Hz, power spectral density lg^2/Hz at ambient temperature

8# Twinaxial Contact (Model: Pin—J1216/90-529; Socket—J1216/91-530)

- Low-level Contact Resistance (Only for Center Contacts and Intermediate Contacts): Initial value 55mΩ, 66mΩ
- after test Test Current and Voltage Drop:

Contact	Test Current (A)	Voltage Drop (mV)		
		25°C		175°C
		Initial	After Test	After Test
Center Contact	1.0	55	66	94
Intermediate Contact	1.0	55	66	94
External Contact	12	75	90	28

- Operating Frequency Range: 0~20MHz
- Rated Operating Voltage: 500 Vrms at sea level; 125 Vrms at 21336m
- Withstand Voltage:

Contact	Altitude	Test Voltage (V) rms
Center to Intermediate	Sea Level	1000
Intermediate to Outer		500

[Differential Contact Performance]

- 8# Differential Contact (2-core model: Pin—CF81/211-01; Socket—CF82/211-01)
- 8# Differential Contact (4-core model: Pin—CF81/411-01; Socket—CF82/411-01)
- Withstand Voltage (Vrms)
- Normal condition: 500V AC from center conductor to outer conductor; 1000V AC between center conductors
- Contact Resistance: ≤15mΩ (center conductor only)
- Insulation Resistance (between center contacts): ≥1000MΩ (at 500Vdc)
- Rated Current of Contact: 1A for center conductor
- Transmission Rate: Up to 1.65Gbps

[Differential Contact Performance]

- Insertion Loss:
 - ≤1.1dB (≤4 cores), ≤1.2dB (≤6 cores), ≤1.4dB (≤8 cores), ≤1.6dB (≤16 cores), ≤2dB (≤61 cores)
- Operating Temperature: -40°C ~ +80°C
- Vibration: 10Hz ~ 500Hz, acceleration: 98m/s²
- Shock: 980 m/s²
- Mechanical Life: 500 cycles
- Tensile Force: ≥800N (main cable)

A950 Harsh Environment High-Density Electrical Connector

[Types of Special Contacts]

Contact Specification	Military Standard Model	US Standard Model	US Standard Model	
			Domestic Wire	Foreign Wire
16# Shielded Pin	J1216/76-424	M39029/76-424	SFF-50-1.5-1	M17/113-RG316
16# Shielded Pin	J1216/77-428	M39029/77-428	SFF-75-1.5-1	
12# Shielded Pin	J1216/28-211	M39029/28-211	SFF-50-1.5-1	M17/113-RG316
	J1216/28-412	M39029/28-412	—	M17/173-RG316D
12# Shielded Socket	J1216/75-416	M39029/75-416	SFF-50-1.5-1	M17/113-RG316
	J1216/75-422	M39029/75-422	—	M17/173-RG316D
12# Coaxial Pin (3GHz)	J1216/102-558	M39029/102-558	SFF-50-1.5-1 SFF-50-1.5-1	M17/113-RG316
12# Coaxial Socket (3GHz)	J1216/103-559	M39029/103-559		
12# Coaxial Pin (40GHz)	J1216/102-558C	—	—	UT-085C-AL-TP-LL (MICRO-COAX)
12# Coaxial Socket (40GHz)	J1216/103-559C	—		
8# Twinaxial Shielded Pin	J1216/90-529	M39029/90-529	M39029/90-529	M17/113-RG316
8# Twinaxial Shielded Socket	J1216/91-530	M39029/91-530		
8# Differential 2-core Pin (100Ω)	CF81/211-01	—	—	HDP700001070
8# Differential 2-core Socket (100Ω)	CF82/211-01	—		
8# Differential 4-core Pin (100Ω)	CF81/411-01	—	—	ET2PC236(Nexans)
8# Differential 4-core Socket (100Ω)	CF82/411-01	—		

Note: Special contacts need to be ordered separately. If optical fiber contacts are needed, please contact our company.

Model Nomenclature

Series Main Name	A950/	20	w	B	35	P	N
Type	20 – Square flange socket 24 – Nut-locked socket 26 – Shielded plug						
Housing and Plating	W – Aluminum alloy plated with army green chromate Z – Aluminum alloy plated with zinc-nickel K – Stainless steel passivation						
Housing No.	09	11	13	15	17	19	21 23 25
Index No.	A to J	A	B	C	D	E	F G H J
Contact Arrangement	See “Contact Arrangement Chart” for details						
Contact Category	P – Pin, crimp type PH – Pin, solder type PL – Pin, long printed circuit board type PC – Pin, short printed circuit board type A – Dedicated pin contact S – Socket, crimp type SH – Socket, solder type SL – Socket, long printed circuit board type SC – Socket, short printed circuit board type B – Dedicated socket contact						
Key Position	N – Normal key position; A, B, C, D, E – Variable key positions						

Note: When the contacts (pins or sockets) in the contact arrangement are configured according to the sample brochure, the contact type is marked as P (or S); if it is necessary to specify that the contacts are configured not according to the sample brochure, change P (or S) to A (or B), and note the number of the specified contact model after the product model.

[Model Marking Example]

A950/20KE06PN

A950 series square flange socket, stainless steel passivation, shell E, contact arrangement 06, with pins, key position N.

Change 6 12# power pins in this socket to 6 12# coaxial pins. The ordering model should be: A950/20KE06AN(6-J1216/102-558)

A950 Harsh Environment High-Density Electrical Connector

Key Position

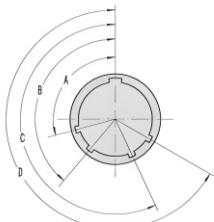
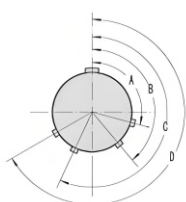
Front View of Socket		Shell Number	Index Number	Angle	N	A	B	C	D	E
Front View of Plug										
		9	A	A°	105	102	80	35	64	91
				B°	140	132	118	140	155	131
				C°	215	248	230	205	234	197
				D°	265	320	312	275	304	240
		11	B	A°	95	113	90	53	119	51
				B°	141	156	145	156	146	141
		13	C	C°	208	182	195	220	176	184
				D°	236	292	252	255	298	242
		15	D	A°	95	113	90	53	119	79
				B°	141	156	145	156	146	153
				C°	208	182	195	220	176	197
				D°	236	292	252	255	298	272
		17	E	A°	80	135	49	66	62	79
				B°	142	170	169	140	145	153
				C°	196	200	200	200	180	197
				D°	293	310	244	257	280	272
		19	F	A°	80	135	49	66	62	79
				B°	142	170	169	140	145	153
				C°	196	200	200	200	180	197
				D°	293	310	244	257	280	272
		21	G	A°	80	135	49	66	62	79
				B°	142	170	169	140	145	153
				C°	196	200	200	200	180	197
				D°	293	310	244	257	280	272
		23	H	A°	80	135	49	66	62	79
				B°	142	170	169	140	145	153
				C°	196	200	200	200	180	197
				D°	293	310	244	257	280	272
		25	J	A°	80	135	49	66	62	79
				B°	142	170	169	140	145	153
				C°	196	200	200	200	180	197
				D°	293	310	244	257	280	272

Contact Arrangement (Mating View of Pin Insulator)

Shell Number	35	M	98	I	02	I	03	I	10	I	11	I		
09 (A)														
11 (B)														
13 (C)														

A950 Harsh Environment High-Density Electrical Connector

15 (D)	19 I 19-20#	02 II 2-12#	03 II 1-16# 2-12#	05 I 5-16#	15 I 1-16# 14-20#	18 I 18-20#	35 M 37-22#
	31 M 1-12# 30-22#	38 II 4-12#	97 I 8-20# 4-16#	14 N 8-22# ; 6-16#	12 M 8-22# ; 2-20# 2-12#		
17 (E)	03 N ★ 1-16# 2-10#	26 I 26-20#	99 I 2-16# 21-20#	06 I 6-12#	08 II 8-16#	35 M 55-22#	
	05 I ★ 5-12#	16 I 3-20# 1-16# ; 2-10#	21 N ★ 4-12# 17-22#	27 I 7-12#	30 N ★ 3-20# 3-10#	39 II ★ 3-TDB4	
	42 M 42-22#	02 I ★ 1-8# Differential 2-core 38-22#	32 I ★ 20-22# 2-8# Differential 2-core	20 I 2-20# 16-22# 2-12# Shielded	22 I ★ 2-8# Double Coaxial	51 I ★ 10-16#	
	24 I 1-16# 2-12# ★ 1-8# Double Coaxial	29 I ★ 6-16# 3-12#	53 I 13-16#	52 I 1-12# ★ 1-8# Double Coaxial	64 I 2-12# ★ 2-8# Double Coaxial		

A950 Harsh Environment High-Density Electrical Connector

19 (F)	32	96	08	39	13	35
	32-20#	★ 9-12#	★ 8-12#	★ 5-TDB4	★ 3-10#	66-22#
	11	28	30	14	10	45
11-16#	2-16# 26-20#	1-16# 29-20#	★ 6-12# 8-20#	2-10#、7-16#	67-22#	
05	93	12	24	53	18	
1-20# 4-10#	2-10# 6-20#、24-22#	1-16# 2-10#、7-20#	★ 4-20# 8-16#、8-22#	★ 53-22#	4-8# Double Coaxial 14-22#	
03	16	19				
★ 3-8# Double Coaxial	2-12# 14-16#	19-16#				
21 (G)	41	16	39	11	35	
	41-20#	16-16#	2-16# 37-20#	11-12#	79-22#	
	25	24	02	27	70	
25-20#	24-20#	65-22#	27_20#	20-16#		

A950 Harsh Environment High-Density Electrical Connector

21 (G)	80 ★ 12-16# 3-12#同轴 ★	05 5-10#	29 ★ 26-20# 3-12#同轴 ★	75 ★ 4-8#双同轴 ★	78 ★ 6-16# 2-8#双同轴 ★	
	55 55-20#	53 53-20#	36 36-20#	35 100-22# M		
23 (H)	32 32-20#	21 21-16#	97 16-16#	34 34-20#		
	2 ★ 85-22#	09 M 2-12# 2-22# 5-10#	99 11-16#	37 ★ 31-20# 6-12#		
	05 ★ 5-8# Double Coaxial ★	04 ★ 4-8# Double Coaxial ★	19 M 4-12# 15-16#			
25 (J)	30 N 16-22# 14-12#	41 ★ 14-22# 24-16# 3-10#	29 29-16#	35 M 128-22#		

A950 Harsh Environment High-Density Electrical Connector

25 (J)	43	19	04	24
	23-20# 20-16#	19-12#	48-20# 8-16#	12-16# 12-12#
	11	12	25	46
2-20# 9-10#	★ 12-10#	★ 8-22# 4-20# 1-16#, 4-12#, 8-10#	40-20# 4-16# 2-8# Double Coaxial	
42	31	07	08	
★ 38-22# 4-8# Double Coaxial	★ 12-20# 5-10# 12-16# 2-8# Double Coaxial	★ 97-22# 2-8# Differential 2-core	★ 8-8# Differential 2-core	
32	37	51	61	
6-10# 16-20# 10-16#	★ 37-16#	★ 4-16# 7-8# Double Coaxial	★ 61-20#	

Note: "★" represents products under development

Contact Specification					
	22#	20#	16#	12#	12# Shielded
	12# Coaxial	10#	8# Double Coaxial	8# Differential 2-core	8# Differential 4-core

- Notes: 1. The 20# hole position can be replaced with a 20# optical fiber contact.
 2. The 16# hole position can be replaced with a 16# shielded or 16# optical fiber contact.
 3. The 12# hole position can be replaced with a 12# shielded, 12# coaxial, or 12# optical fiber contact.
 4. The 8# hole position can be replaced with an 8# double coaxial or 8# differential contact.

A950 Harsh Environment High-Density Electrical Connector

Contact Specification

[Plug A950/26]

	Shell Number	Thread A	Bmax
	09(A)	M12×1-6g	21.5
	11(B)	M15×1-6g	24.5
	13(C)	M18×1-6g	27.5
	15(D)	M22×1-6g	31.5
	17(E)	M25×1-6g	34.5
	19(F)	M28×1-6g	37.5
	21(G)	M31×1-6g	40.5
	23(H)	M34×1-6g	43.5
	25(J)	M37×1-6g	46.5

[Square Flange Socket A950/20]

	Shell Number	A	B	C	Thread D	E	F	G	H	J	d1min	d2min
	09(A)	20.7	10.8	2.5	M12×1-6g	23.8	18.26	15.09	3.25	5.49	16.66	13.11
	11(B)	20.7	10.8	2.5	M15×1-6g	26.2	20.62	18.26	3.25	4.93	20.22	15.88
	13(C)	20.7	10.8	2.5	M18×1-6g	28.6	23.01	20.62	3.25	4.93	23.42	19.05
	15(D)	20.7	10.8	2.5	M22×1-6g	31.0	24.61	23.01	3.25	4.39	26.59	23.01
	17(E)	20.7	10.8	2.5	M25×1-6g	33.3	26.97	24.61	3.25	4.93	30.96	25.81
	19(F)	20.7	10.8	2.5	M28×1-6g	36.5	29.36	26.97	3.25	4.93	32.94	28.98
	21(G)	19.9	11.6	3.2	M31×1-6g	39.7	31.75	29.36	3.25	4.93	36.12	32.18
	23(H)	19.9	11.6	3.2	M34×1-6g	42.9	34.93	31.75	3.91	6.15	39.29	34.93
	25(J)	19.9	11.6	3.2	M37×1-6g	46.0	38.10	34.93	3.91	6.15	42.47	37.69

A950 Harsh Environment High-Density Electrical Connector

[Nut Fastened Socket A950/24]

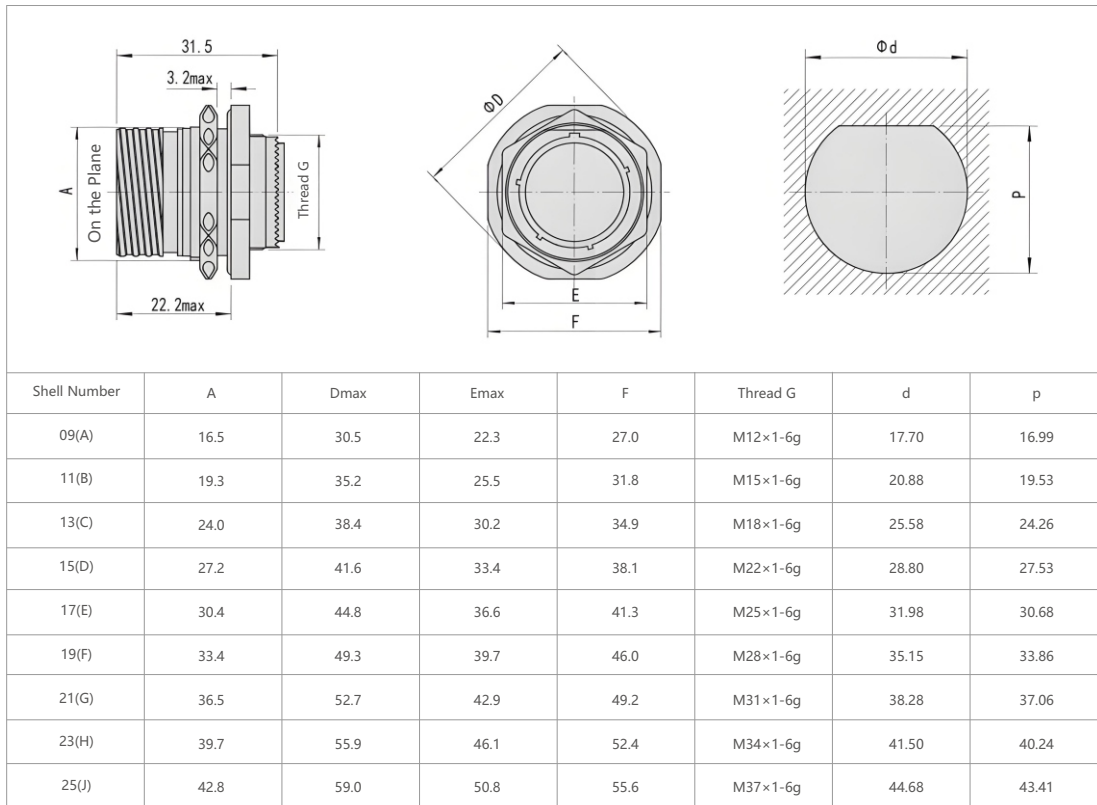

[Nut Fastened Socket A950/24]

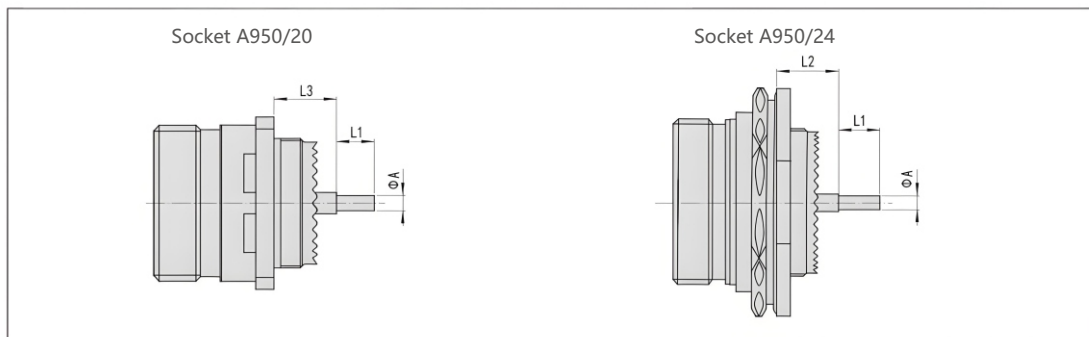

Printed Circuit Board Type Contact Specifications		L1	A
22#	Long-type Printed Circuit Board Contact	8.5	0.7
	Short-type Printed Circuit Board Contact	4.0	
20#	Long-type Printed Circuit Board Contact	8.5	0.7
	Short-type Printed Circuit Board Contact	5.1	
16#	Long-type Printed Circuit Board Contact	8.5	1.15
	Short-type Printed Circuit Board Contact	5.1	

A950 Harsh Environment High-Density Electrical Connector

Dimensions with Different Contact Specifications			Housing No. A-B	Housing No. C-D-E-F-G-H-J
L2	When Installing 22# Pin	min	10.52	10.34
		max	11.46	11.28
	When Installing 22# Socket	min	10.19	10.01
		max	11.46	11.28
	When Installing 20# or 16# Pin, Socket	min	10.69	10.51
		max	11.63	11.45
L3	When Installing 22# Pin	min	9.48	9.48
		max	10.58	10.58
	When Installing 22# Socket	min	9.15	9.15
		max	10.58	10.58
	When Installing 20# or 16# Pin, Socket	min	9.65	9.65
		max	10.75	10.75

[Welded Connector]

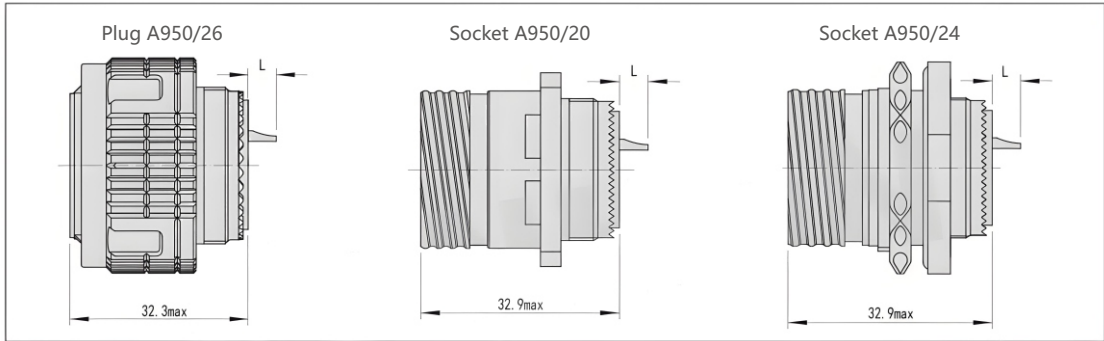

Welded Type Contact Specifications	L	Inner Diameter of Welding Cup	Maximum Compatible Wire Gauge (AWG)
22#	4	φ0.9	22
20#	4	φ1.1	20
16#	4	φ1.9	16
12#	4	φ2.9	12
10#	6	φ3.6	10

Note: Coaxial contacts have no welded-type contacts. (Provided as loose pieces for 28# contacts.)

Dimension After Plug and Socket Mating

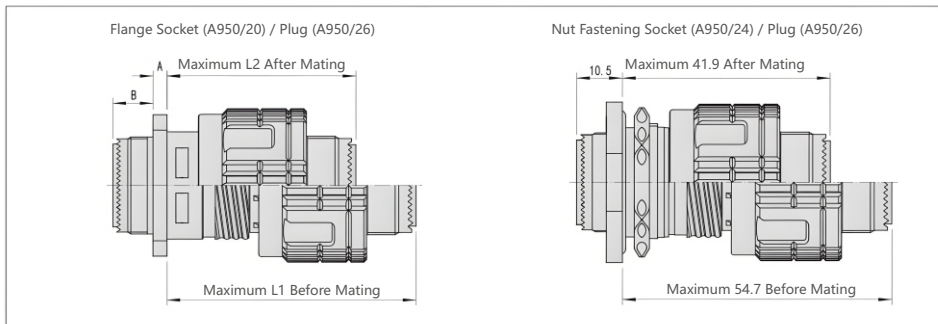

A950 Harsh Environment High-Density Electrical Connector

Shell Number		09(A)	11(B)	13(C)	15(D)	17(E)	19(F)	21(G)	23(H)	25(J)
L1	max	53.2	53.2	53.2	53.2	53.2	53.2	52.4	52.4	52.4
L2	max	40.3	40.3	40.3	40.3	40.3	40.3	39.6	39.6	39.6
A	max	2.5	2.5	2.5	2.5	2.5	2.5	3.2	3.2	3.2
B	max	9.6	9.6	9.6	9.6	9.6	9.6	9.6	9.6	9.6

Plug and Socket Sealing Cover

[Model Naming]

Series Main Name	A950/	32	w	09	N
Type	32 - Plug Sealing Cover 33 - Socket Sealing Cover				
Housing and Plating	W - Aluminum Alloy with Copper Plating (Military Green) Z - Aluminum Alloy with Zinc-Nickel Plating K - Stainless Steel Passivation				
Shell Number	09-11-13-15-17-19-21-23-25				
Chain Type	R - Stainless Steel Wire Rope with Connecting Piece (For Flange Socket) C - Nylon Wire Rope with Connecting Piece (For Flange Socket) N - Stainless Steel Wire Rope Loop (For Nut Fastening Socket) S - Nylon Wire Rope Loop (For Nut Fastening Socket)				

Note: Sealing covers should be ordered separately and are not supplied with the connector.[Outline Dimensions]

[Outline Dimensions]

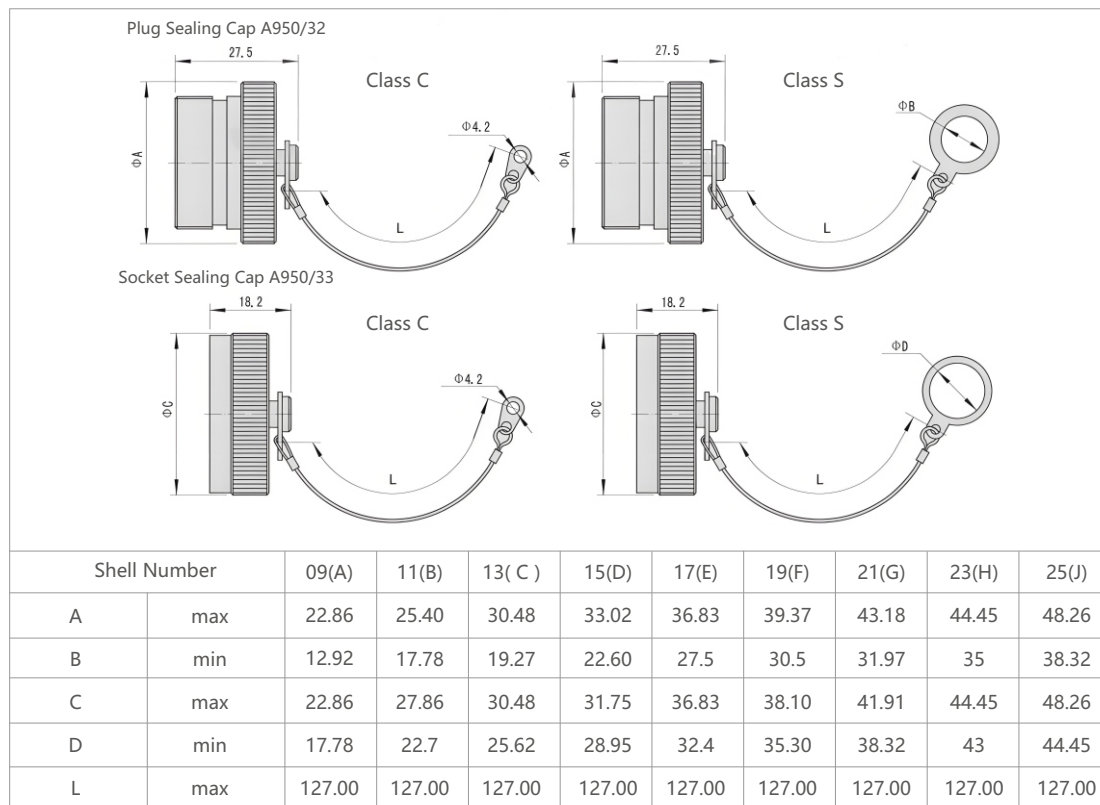

A950 Harsh Environment High-Density Electrical Connector

Rear Accessory

This type of accessory is used to fix wires and seal cables. It is divided into two types: straight and bent. Both have built-in pressing plates to clamp cables or wires. Meanwhile, the pressing plates can also clamp shielding nets to achieve shielding.

Connector Type	Function Type of Adapted Cable Accessory	Model of Adapted Cable Accessory
A950 Series General Crimp-type Connector	Accessories without Cable Clamping and Shielding	1、J1784/14
	Accessories with Cable Clamping but without Shielding	1、J1784/38
		2、J1784/39
		3、J1784/16
	Shielded Accessories without Cable Clamping	1、J1784/20
		2、J1784/69
		3、J1784/88
		4、J1784/90
		5、JY599III-FJA00
		6、JY599III-FJA90
		7、JY599III-xxFJB00F
		8、JY599IIIxxFJC00
		9、JY599IIIxxFJE00
	Accessories with Cable Clamping and Shielding	1、J1784/38-xxNB
		2、J1784/18 Series
A950 Series General Solder-type Connector	Accessories without Cable Clamping and Shielding	3、J1784/14
	Accessories with Cable Clamping but without Shielding	4、J1784/38H
		5、J1784/16H
		1、J1784/20
	Shielded Accessories without Cable Clamping	2、J1784/69
		3、J1784/88
		4、J1784/90
		5、JY599III-FJA00
		6、JY599III-FJA90
	Accessories with Cable Clamping and Shielding	1、J1784/18 Series
A950/18, A950/38, A950/19, and A950/39 are applicable to A950 series solder-type and crimp-type connectors.		

A950 Harsh Environment High-Density Electrical Connector

[Model Naming]

Series Main Name	A950/	18-1	15	w	01
Type	38 – Straight Shielded Accessory 39 – Angled Shielded Accessory 18 – Straight Shielded Sealing Accessory 19 – Angled Shielded Sealing Accessory				
Shell Number	09-11-13-15-17-19-21-23-25				
Housing and Plating	W – Aluminum Alloy with Cadmium Plating (Military Green) Z – Aluminum Alloy with Zinc-Nickel Plating K – Stainless Steel Passivation				
Outlet Coding	Sealing Accessories: 01, 02..... Non-sealing Accessories: Not Indicated				

Note: This accessory is not compatible with the front-mounted structure of A950/20 series sockets.

[Overall Dimensions]

A950/18-XXXX

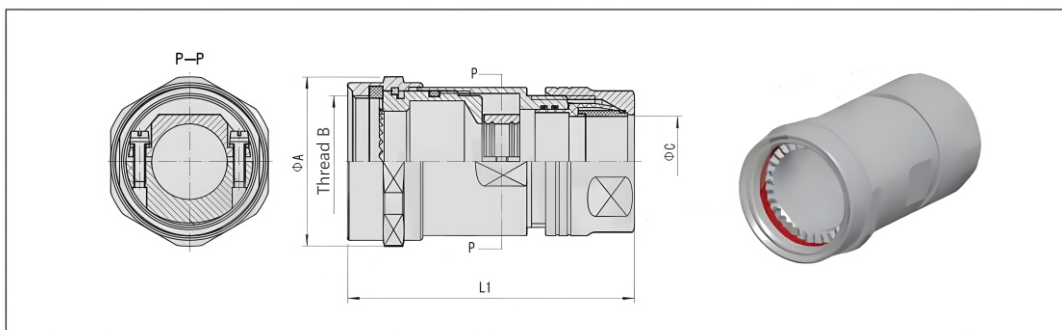

A950/18-XXXX

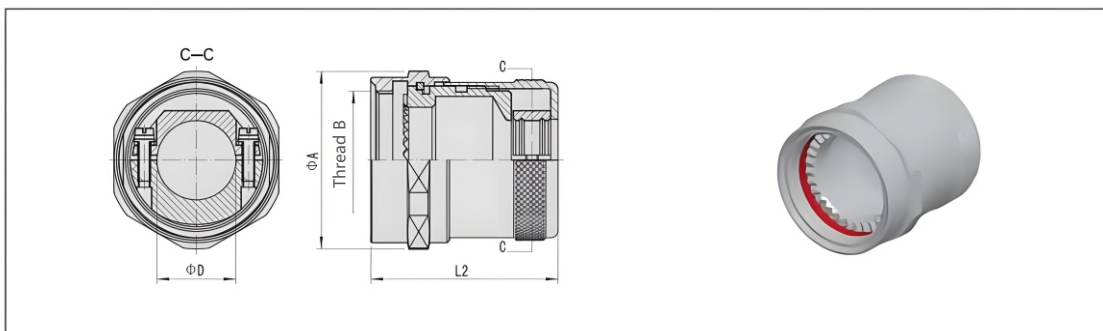

A950 Harsh Environment High-Density Electrical Connector

A950/19-XXXX

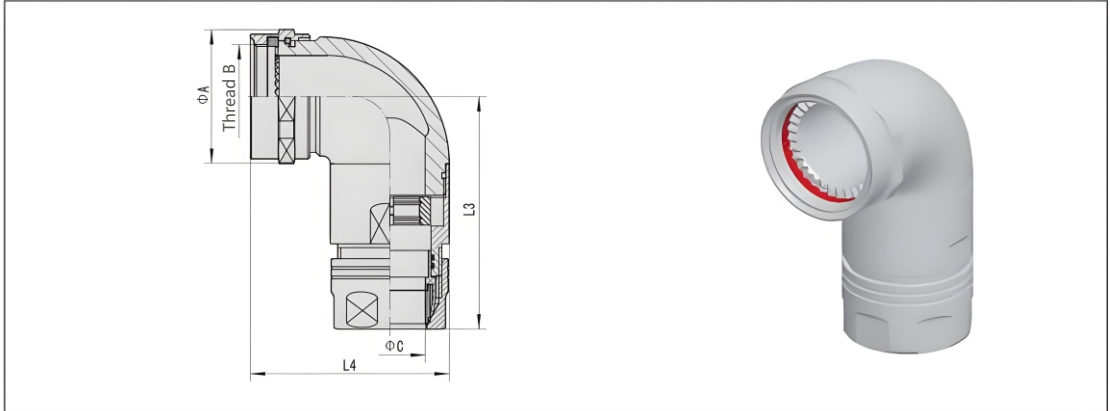

A950/39-XXXX

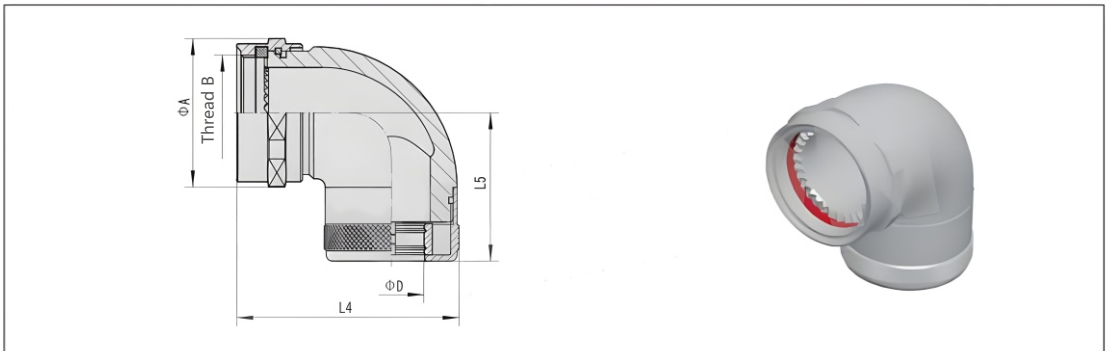

Table 1

Shell Number	A	Thread B	L1 MAX	L2 MAX	L3 MAX	L4 MAX	L5 MAX	Outlet Diameter of Shielded Sealing Accessory C Code)	Outlet Diameter of Shielded Accessory D (max)
09	19	M12×1	47.6	28.7	47.4	39.2	26	01, 02	4
11	22.2	M15×1	49.6	30.2	48.0	40.7	26	01, 02, 03	7
13	25.4	M18×1	52.1	31.7	52.0	46.2	29	01, 02, 03	10
15	29.6	M22×1	57.7	33.2	56.0	48.0	29	01, 02, 03	12
17	32.8	M25×1	59.7	35.2	60.0	51.7	33	01, 02, 03	14
19	36	M28×1	64.7	38.3	62.0	54.5	33	01, 02, 03	16
21	39.2	M31×1	68.0	41.5	68.0	56.7	39	01, 02, 03	19
23	42.4	M34×1	71.0	44.6	68.0	59.2	39	01, 02, 03	22
25	45.6	M37×1	73.1	46.7	73.0	64.7	44	01, 02, 03	25

A950 Harsh Environment High-Density Electrical Connector

Table 2

Shell Number	Outlet Diameter Code	Outlet Dimension Range(C)
09	01	3.5~5.5
	02	2~4
11	01	5~7.5
	02	3.5~5.5
13	01	7.5~10.5
	02	5~7.5
	03	3.5~5.5
15	01	8.5~12
	02	7.5~10.5
	03	5~7.5
17	01	10.5~15
	02	8.5~12
	03	7.5~10.5
19	01	13.5~18
	02	10.5~15
	03	8.5~12
21	01	16.5~21
	02	13.5~18
	03	10.5~15
23	01	18.5~23.5
	02	16.5~21
	03	13.5~18
25	01	21.5~26.5
	02	18.5~23.5
	03	16.5~21

[Overall Dimensions]

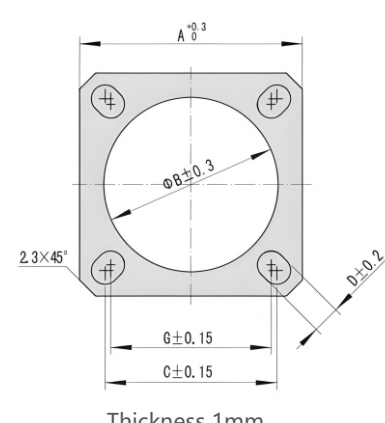
	Compatible Shell Number	Flange Rubber Pad Code	Conductive Flange Rubber Pad Code	A	B	C	G	D
		A	21E8-701-885	21E8-701-886	23.9	16.1	18.26	15.09
	B	21E8-701-887	21E8-701-888	26.3	19.2	20.62	18.26	3.3
	C	21E8-701-889	21E8-701-890	28.7	22.4	23.01	20.62	3.3
	D	21E8-701-891	21E8-701-892	31.1	25.6	24.61	23.01	3.3
	E	21E8-701-893	21E8-701-894	33.4	30.4	26.97	24.61	3.3
	F	21E8-701-895	21E8-701-896	36.6	32.0	29.36	26.97	3.3
	G	21E8-701-897	21E8-701-898	39.8	34.9	31.75	29.36	3.3
	H	21E8-701-899	21E8-701-900	43.0	38.3	34.93	31.75	4.0
	J	21E8-701-901	21E8-701-902	46.1	41.4	38.10	34.93	4.0

GJB599 Series III High and Low Frequency Hybrid Integrated Marine Environment-Resistant Electrical Connector

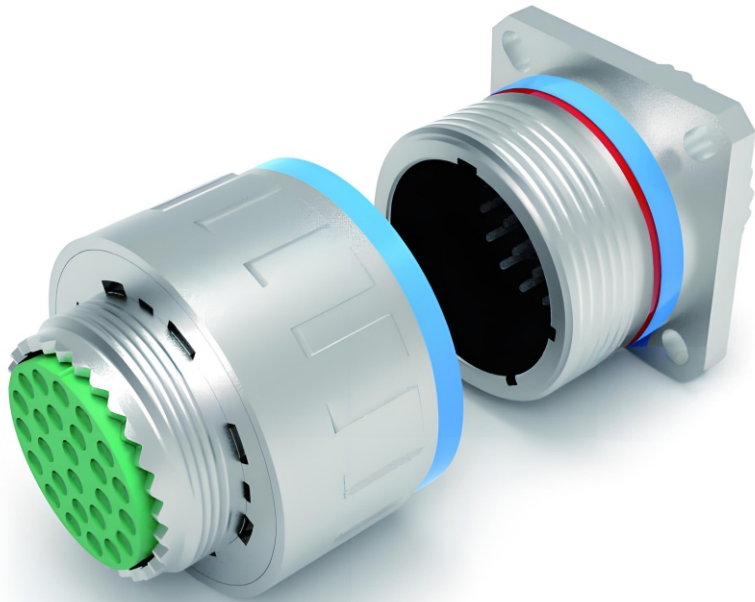

The pictures are for reference only

GJB599 Series III High and Low Frequency Hybrid Integrated Marine Environment-Resistant Electrical Connector

Product Introduction

- This series of connectors fully complies with the national military standard GJB599A (equivalent to the US military standard MIL-DTL-38999K) Series III.
- It can realize hybrid installation of power, high-speed, and high-frequency.
- It can realize replacement and installation of different types of contact parts with the same specification number.
- It can realize integrated connection of microwave signals, high-speed data, and power control signals.
- It has a three-head thread for quick mating and is equipped with an anti-loosening mechanism.
- It is anti-misinsertion.
- It has excellent EMI/RFI shielding effect.

Application Fields

The product is suitable for the connection of aerospace vehicles, as well as other electronic and electrical equipment. It is applicable to complex environments such as strong vibration, rain, sandstorm, and humidity. When selecting connector shell materials, try to be consistent with the shell material of the airborne equipment to avoid contact between different types of metals. When unavoidable, the compatibility between metal materials should be considered, and protective measures should be taken at the same time to avoid galvanic corrosion.

The product can withstand marine environmental indicators such as acidic salt spray, acidic atmosphere, and mold.

Main Technical Performance

[Mechanical Performance]

Plating Layer:

- W—Aluminum alloy with military green coating
- TA—High-performance titanium alloy
- K—High-performance stainless steel passivation
- J—Composite material with military green coating
- M—Composite material with nickel plating
- Insulator: Thermoplastic material or thermosetting material

Wire Seal and Sealing Ring: Rubber

- Contact Part: Copper alloy with gold plating

Service Life*: 500 mating cycles

- Shock*: 3ms half-sine wave, acceleration peak 300g

Vibration*:

- Sine vibration: 10~50Hz, speed 254mm/s;
- 50~140Hz, double amplitude 1.5mm;
- 140~2000Hz, acceleration 598m/s²
- Random vibration: At high temperature, 50~2000Hz, root mean square value 41.7G (100~2000Hz, power spectral density 1g²/Hz);
At ambient temperature, 25~2000Hz, root mean square value 49.5G (100~300Hz, power spectral density 5g²/Hz)
- Contact Part Fixing Force*: (Minimum force measured by Newton meter)
22D: 45N; 20#: 67N; 8#: 111N; 12#: 111N; 16#: 111N

Note:

The indicators marked with "*" are determined based on the minimum performance of the contact part type matched with the product.

[Electrical Performance]

Shell Conductivity

Type W: 2.5 mΩ Types TA, K: 10 mΩ

Shielding Performance

- 65dB at 10GHz (Type F)
- 50dB at 10GHz (Type W)
- 85dB at 1GHz (Types F and W)

Withstand Voltage (V)

Working Conditions	Sea Level	At 21,000m Altitude
M	1300	800
N	1000	600
I	1800	1000
II	2300	1000

Insulation Resistance: ≥5000MΩ at 500Vdc

[Environmental Performance]

- Temperature Range
Types W, J: -65°C ~ 175°C Types TA, K, M: -65°C ~ 200°C
- Sealing: Mated connectors meet the low-pressure immersion requirements of MIL-DTC-38999K
- Humidity and Heat: In accordance with MIL-C-38999: 10 cycles of 24 hours each
- Liquid Resistance: Resistant to multiple fuels, coolants, and solvents (for oil-resistant products) Acidic Salt Spray Resistance
Type W: 192h (per GJB50, pH value 3.5±0.5)
Types K, TA, J, M: 240h (per GJB150, pH value 3.5±0.5)
- Acidic Atmosphere Resistance: Per GJB150, single cycle period is 2h of spraying + 7d of storage, 4 cycles
- Mold Resistance: Per GJB150.10A—2009, using 2 types of fungi + Aspergillus brevicaulis, test period 84 days, mold resistance requirement not lower than Level 1

GJB599 Series III High and Low Frequency Hybrid Integrated Marine Environment-Resistant Electrical Connector

**[Electrical Performance of Contacts]
Power Contacts**

Contact Resistance

22D: 14.6mΩ; 20#: 7.3mΩ 16#: 3.8mΩ; 12#: 1.7mΩ

Rated Current of Contacts

22D: 5A; 20#: 7.5A 16#: 13A; 12#: 23A 10#: 40A

12# Shielded Contacts

Low-Level Contact Resistance (Only for Inner Contacts):

Initial value: 55mΩ; After test: 66mΩ.

Contacts	Test Current (A)	Voltage Drop (mV) max		
		25 ^{±3} °C		200 ⁺³ °C
		Normal conditions	After test	
Inner Contacts	1	170	204	290
Outer Contacts	12	150	180	255

Withstand Voltage: Sea level: 750V;

15240m (11.59KPa): 250 Vrms

12# Coaxial Contact

Nominal Impedance: 50Ω

Low-Level Contact Resistance

(Only Applicable to Inner Contact)

Maximum Contact Resistance (mΩ) max	
Initial Value	After Test
55	66

Withstand Voltage: Sea level: 1000V;

15240m (11.59KPa): 250Vrms

Contact Resistance (Voltage Drop and Test Current):

Voltage Drop (mV) max

Contacts	Test Current (A)	Voltage Drop (mV) max		
		25 ^{±3} °C		200 ⁺³ °C
		Normal Condition	After Test	
Inner Contacts	1	55	66	94
Outer Contacts	12	75	90	128

8# Twin Coaxial Contact

Low-Level Contact Resistance (Only Applicable to Center Contact and Intermediate Contact)

Maximum Contact Resistance (mΩ) max	
Initial Value	After Test
55	66

Contact Resistance (Test Current and Voltage Drop):

Contacts	Test Current (A)	Maximum Voltage Drop (mV) max		
		25°C		175°C
		Initial	After Test	
Center Contact	1.0	55	66	94
Middle Contact	1.0	55	66	94
Outer Contact	12	75	90	128

Operating Frequency Range: 0~20MHz

Rated Operating Voltage: Sea level: 500 Vrms; 21336m: 125 Vrms

Withstand Voltage:

Contacts	Altitude	Test Voltage (V) rms
Center to Middle	Sea Level	1000
Middle to Outer		500

16# Shielded Contact

Low-Level Contact Resistance (Only Applicable to Inner Contact)

Maximum Contact Resistance (mΩ) max	
Initial Value	After Test
170	204

Test Current and Voltage Drop:

Contacts	Test Current (A)	Voltage Drop (mV)		
		25°C		175°C
		Initial	After Test	
Center Contact	1	170	204	290
Middle Contact	12	150	180	255

Rated Operating Voltage (Between Inner and Outer Contacts):

Sea Level: 750 Vrms; 15240m: 250 Vrms

Voltage Standing Wave Ratio (VSWR):

In the frequency range of 500MHz ~ 3GHz, under the following three conditions, the VSWR shall not exceed 1.20 + 0.04F (where F is in GHz):

- (1) Pin and socket contacts are fully mated;
- (2) Pin and socket contacts are mated by 1.27±0.13mm;
- (3) Pin and socket contacts are mated by 2.54±0.13mm;

Insertion Loss: dBmax = 0.11√F

(where F is in GHz). When measured at 3GHz according to MIL-C-39012, the insertion loss shall not exceed 0.20dB.

TDB4 Contact

Impedance: 50Ω

Operating Frequency: 0~10GHz

Voltage Standing Wave Ratio (VSWR): Not greater than 1.3

Withstand Voltage (Between Center Conductor and Outer Conductor): 750 (Vrms)

Insulation Resistance: Greater than or equal to 1000MΩ at 500Vdc

8# Differential Contact

Withstand Voltage (Vrms)

Normal condition: Center conductor to outer conductor: 500V AC

Between center conductors: 1000V AC

Contact Resistance

≤15mΩ (center conductor only)

Insulation Resistance (between center contacts)

≥1000MΩ at 500Vdc

Rated Current of Contact

Center conductor: 1A

Transmission Rate up to 1.65Gbps

GJB599 Series III High and Low Frequency Hybrid Integrated Marine Environment-Resistant Electrical Connector

Special Contacts Selected for GJB599 Series III

Contact Specification	National Military Standard Model	Adapted Wire	
		Domestic Wire	Foreign Wire
16# Shielded Pin	J1216/M76-424	SFF-50-1.5-1	M17/113-RG316
16# Shielded Socket	J1216/M77-428	SFF-75-1.5-1	
12# Shielded Socket	J1216/M28-211	SFF-50-1.5-1	M17/113-RG316
	J1216/M28-412		M17/113-RG316D
12# Shielded Pin	J1216/M75-416	SFF-50-1.5-1	M17/113-RG316
	J1216/M75-422		M17/113-RG316D
12# Coaxial Pin	J1216/M102-558	SFF-50-1.5-1	M17/113-RG316
12# Coaxial Socket	J1216/M103-559	SFF-75-1.5-1	
8# Twinaxial Shielded Pin	J1216/M90-529	SFF-78-1-51	M17/176-00002
8# Twinaxial Shielded Socket	J1216/M91-530		
8# Differential 2-core Pin 100Ω	CF81/211-01M		HDP700001070
8# Differential 2-core Socket 100Ω	CF82/211-01M		
8# Differential 4-core Pin 100Ω	CF81/411-01M		CEC-RWC-18664 ABS1503KD24
8# Differential 4-core Socket 100Ω	CF82/411-01M		

[Model Naming]



Series Main Name	J599/ 20 M W B 10 P N -S
Type	20-Square Flange Socket; 24-Nut Fastened Socket (All three types can be installed with rear accessories); 26-Shielded Plug
Category	M-Marine Environment (Resistant to Marine Environment)
Shell Plating	W-Aluminum Alloy Military Green Coating (Recommended for Internal Closed Areas and Well-Environmented Internal Semi-Closed Areas); TA-High-Performance Titanium Alloy (Recommended for Open Exposed Areas and Poor-Environmented Internal Semi-Closed Areas); K-High-Performance Stainless Steel Passivation (Recommended for Open Exposed Areas and Poor-Environmented Internal Semi-Closed Areas); J-Composite Material Military Green Coating (Recommended for Internal Closed Areas); M-Composite Material Electroless Nickel Plating (Recommended for Internal Closed Areas)
Shell Plating Index Number	09 11 13 15 17 19 21 23 25 A to J A B C D E F G H J
Contact Arrangement	See "Contact Arrangement Diagram" for details
Contact Type*	P-Pin, A-Specified Matching Pin; S-Socket, B-Specified Matching Socket; PF-8# Differential Pin; SF-8# Differential Socket
Key Position	N-Normal Key Position; A, B, C, D, E-Variant Key Positions
Safety Structure Mark (Select When Safety is Required)	-S (Applicable to Plugs and Sockets, square flange sockets are equipped with M312 double safety hole screws); -S08 (Equipped with M38 double safety hole screws, applicable to square flange sockets); -S10 (Equipped with M310 double safety hole screws, applicable to square flange sockets); -S14 (Equipped with M314 double safety hole screws, applicable to square flange sockets); -S16 (Equipped with M3*16 double safety hole screws, applicable to square flange sockets)

Notes:

- When configuring pins (or sockets) according to the sample publicity in the contact arrangement, the contact type is indicated as P (or S) when it is necessary to specify the configuration of contacts not according to the sample publicity, change P (or S) to A (or B), and note the type and quantity of the specified contacts in the product model backup, but the type and quantity of the specified contacts are not indicated on the product marking.
- When the plug is equipped with a fuse, the fuse uses Φ0.5 soft stainless steel wire.
- To avoid electrochemical corrosion and enhance corrosion resistance, when the shell plating is a military green coating, the surfaces of metal parts (mounting panels, screws, flat washers, spring washers, fuses, etc.) in contact with the connector shell should be plated with cadmium (or dipped in varnish or other platings that do not cause potential corrosion with cadmium). The order number of cadmium-plated flat washers is 21E8-142-4269-H15. When the shell material is high-performance titanium alloy, the metal parts (mounting panels, screws, flat washers, spring washers, fuses, etc.) in contact with the connector shell should be made of 316L stainless steel (or dipped in varnish or other platings that do not cause potential corrosion with titanium alloy).

[Model Naming Example]

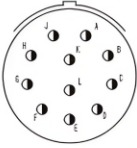
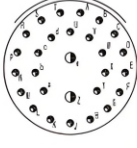
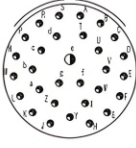
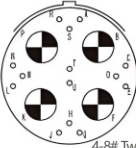
Square flange receptacle, marine environment resistant, high-performance titanium alloy, Shell Type E, 06 contact arrangement, equipped with pins, Key Position N, model: J599/20MKE06PN.
Change the 6 pieces of 12# power pins in this connection to 6 pieces of 12# coaxial pins; the order model should be: J599/20MKE06AN (6-J1216/M102-558).

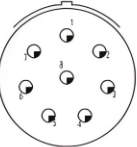
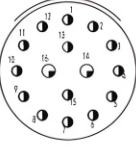
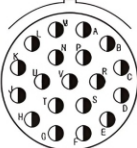
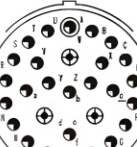
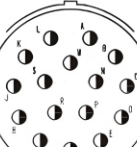
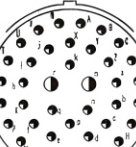
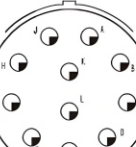
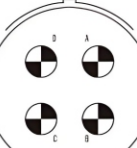
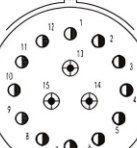
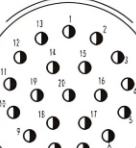
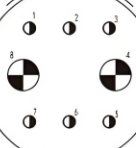
19 (F)	11 II  11-16#	28 I  26-20# 2-16#	30 I  29-20# 1-16#	18 M  4-8# Twin Coaxial 14-22D#
	03  3-8# Twin Coaxial	08 N  8-12#	16 M  2-12# 14-16#	
	19 M  16-16#			
21 (G)	29 M  26-20# 3-12# Coaxial	16 II  16-16#	39 I  37-20# 2-16#	11 II  11-12#
	75 M  4-8# Twin Coaxial	80 M  12-16# 3-12# Coaxial	70 M  20-16#	78  6-16# 2-8# Twin Coaxial

GJB599 Series III High and Low Frequency Hybrid Integrated Marine Environment-Resistant Electrical Connector

23 (H)	<p>99 II</p> <p>11-16#</p>	<p>21 II</p> <p>21-16#</p>	<p>97 I</p> <p>16-16#</p>	<p>04 N</p> <p>4-8# Twin Coaxial</p>
	<p>37</p> <p>31-20# 6-12#</p>	<p>05 N</p> <p>5-8# Twin Coaxial</p>	<p>09</p> <p>6-12#</p> <p>3-8# Twin Coaxial</p>	<p>19</p> <p>4-12# 15-16#</p>
	<p>15</p> <p>16-16#</p>	<p>29</p> <p>29-16#</p>		
25 (J)	<p>46 I</p> <p>40-20# 4-16#</p> <p>2-8# Twin Coaxial</p>	<p>29 I</p> <p>29-16#</p>	<p>04 I</p> <p>48-20# 8-16#</p>	<p>24 I</p> <p>12-16# 12-12#</p>
	<p>43 I</p> <p>23-20# 20-16#</p>	<p>19 I</p> <p>19-12#</p>	<p>42</p> <p>4-8# Twin Coaxial</p>	<p>31 N</p> <p>12-20# 12-16# 5-10#</p> <p>2-8# Twin Coaxial</p>

GJB599 Series III High and Low Frequency Hybrid Integrated Marine Environment-Resistant Electrical Connector

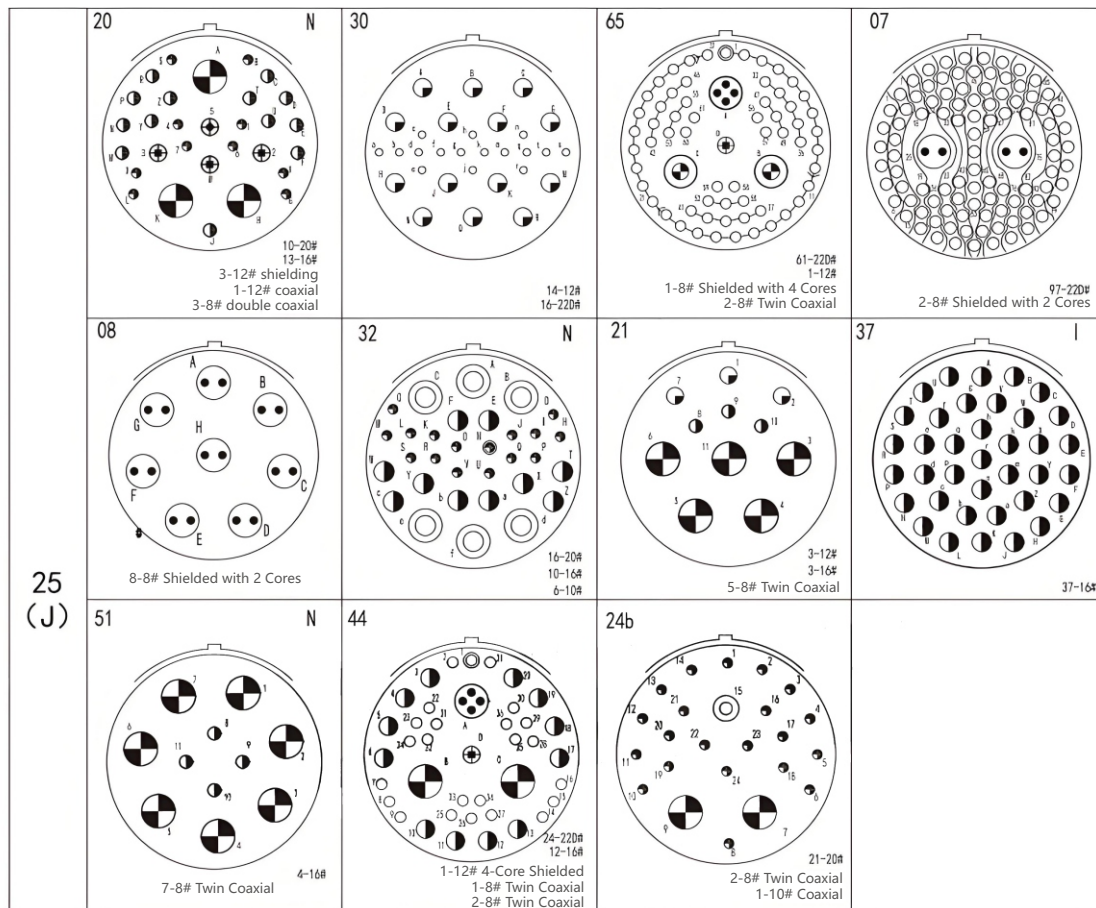

Power Contact Component Specifications

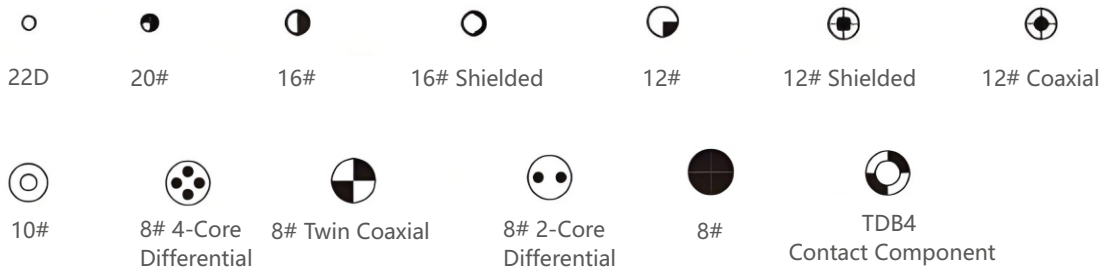

GJB599 Series III (MIL-DTL-38999 Series III) Electrical Connector

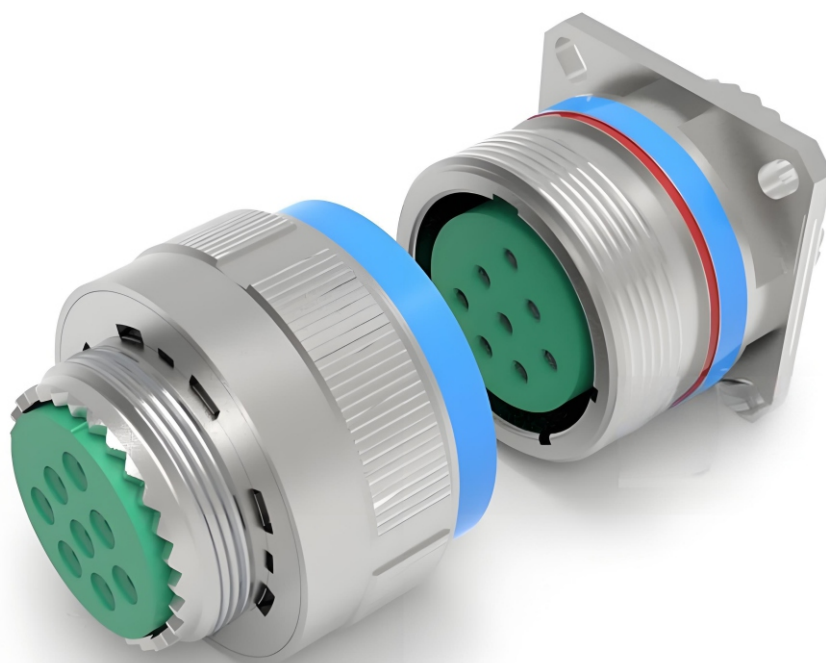

The pictures are for reference only

GJB599 Series III (MIL-DTL-38999 Series III) Electrical Connector

Product Introduction

- Compliant with GJB 599A (MIL-DTL-38999K) Series III
- Three-thread quick connection with anti-loosening mechanism
- Small size, light weight, and high contact density
- With electromagnetic shielding function
- Contacts can be removed by pressing, and the plug-in design prevents misinsertion
- Positions of 12# and 16# contact specifications can be equipped with optical fiber contacts
- Positions of 12#, 10#, and 8# contact specifications can be equipped with coaxial and shielded contacts
- Available with fireproof housings, composite housings, aluminum alloy housings, and various platings
- With high environmental adaptability: -210°C to +204°C, +102°C, suitable for use in harsh sandstorm and humid environments
- With high vibration resistance



Applications

The product is used for circuit signal connection.

Main Performance

[Mechanical Performance]

- Housing: Aluminum alloy, stainless steel, titanium alloy
- Plating:
 - W – Cadmium plating (olive green)
 - F – Electroless nickel plating
 - K – Stainless steel passivation
 - TA – Titanium alloy
 - FT – Aluminum alloy plated with silver
- Insulator: Thermoplastic or thermosetting material
- Sealing Component and Seal: Silicone rubber
- Contact Plating: Copper alloy plated with gold
- Service Life: 500 mating cycles
- Impact: 30ms half-sine wave, acceleration peak value 300g

[Electrical Performance]

Withstand Voltage: V

Working Condition	Sea Level	At 21,000m Altitude
M	1300	800
N	1000	600
I	1800	1000
II	2300	1000

Note: Different contact arrangements have different working levels. For details, please refer to the superscript in the contact arrangement.

Contact Resistance and Rated Current of Contacts:

Contact Specification	Working Diameter (mm)	Contact Resistance (mΩ)	Rated Current (A)
22D	Φ0.76	≤12	5
20#	Φ1.00	≤5	7.5
16#	Φ1.60	≤2.5	13
12#	Φ2.40	≤1.5	23
10#	Φ3.15	≤1.0	40

[Environmental Performance]

Temperature Range:

Type W: -65°C ~ +175°C

Types F, K, FT, TA: -65°C ~ +200°C

Sealing: Mated connectors meet the

low-pressure impregnation requirements of MIL-DTL-38999K

Operating Environment

The product is used in complex environments such as strong vibration, rain, wind and sand, and humidity.

Vibration:

Sine: 60g, with temperature cycling and simulated accessories (36 hours)

Random: At high temperature, frequency 100~1000Hz, power spectral density 1g²/Hz, corresponding root mean square value 41.7g;

At ambient temperature, frequency 100~1000Hz, power spectral density 5g²/Hz, corresponding root mean square value 49.5g

Contact Retention Force (minimum force in Newtons):

22D: 45N

20#: 67N

16#: 111N

12#: 111N

10#: 111N

8#: 111N

Insulation Resistance: ≥5000MΩ (500VDC)

Housing Conductivity:

Type W: 2.5 mΩ

Types F, FT: 1 mΩ

Types K, TA: 10 mΩ

Electromagnetic Interference Shielding:

At 100MHz~1GHz, minimum attenuation is 85dB (Types F, W)

At 1GHz~10GHz, minimum attenuation is 65dB (Type F), 50dB (Type W)

8# Dual Coaxial Contact:

Frequency bandwidth: 0~20MHz

Rated Voltage: Maximum 500VAC; At 21,000m: 125VAC

Voltage Drop: Inner and middle contacts: ≤55mV at 1A;

Outer contacts: ≤75mV at 12A

Salt Spray:

Type W: 500h

Type F: 48h

Types K, TA: 1000h

Type FT: 96h

Humidity and Heat: According to MIL-DTL-38999K: 10 cycles of 24 hours each

Liquid Resistance: Resistant to multiple fuels, coolants, and solvents

GJB599 Series III (MIL-DTL-38999 Series III) Electrical Connector

[Model Naming]

Series Main Name	J599/	20	W	B	35	P	10	N	-S																				
Type	20 - Flange Socket 24 - Nut Fastened Socket 26 - Shielded Plug (All three types can be installed with accessories)																												
Housing Plating	W - Cadmium Plated Olive Green F - Electroless Nickel Plating K - Stainless Steel Passivation			FT - Aluminum Alloy Plated with Nickel TA - Titanium Alloy																									
Shell Plating Index Number	<table style="width: 100%; border: none;"> <tr> <td style="border: none;">09</td><td style="border: none;">11</td><td style="border: none;">13</td><td style="border: none;">15</td><td style="border: none;">17</td><td style="border: none;">19</td><td style="border: none;">21</td><td style="border: none;">23</td><td style="border: none;">25</td><td style="border: none;"></td> </tr> <tr> <td style="border: none;">A to J</td><td style="border: none;">A</td><td style="border: none;">B</td><td style="border: none;">C</td><td style="border: none;">D</td><td style="border: none;">E</td><td style="border: none;">F</td><td style="border: none;">G</td><td style="border: none;">H</td><td style="border: none;">J</td> </tr> </table>									09	11	13	15	17	19	21	23	25		A to J	A	B	C	D	E	F	G	H	J
09	11	13	15	17	19	21	23	25																					
A to J	A	B	C	D	E	F	G	H	J																				
Contact Arrangement	See "GJB599III Series Contact Arrangement" Diagram (If the contact arrangement is letter marking, add "e" after the contact code to indicate number marking)																												
Contact Category	P - Pin, Crimp and Weld Type PL - Pin, Long PCB Type PC - Pin, Short PCB Type A - Special Pin Contact			S - Socket, Crimp and Weld Type SL - Socket, Long PCB Type SC - Socket, Short PCB Type B - Special Socket Contact																									
Key Position	N - Normal Key Position A, B, C, D, E - Variable Key Positions																												
Welded Contact Identification (Only for Welded Connectors)																													
H - Welded Contact																													
-S (For Plugs and Sockets, Flange Socket with M312 Air Mark Screw)																													
-S10 (With M310 Air Mark Screw, for Flange Sockets)																													
With Insurance -S14 (With M314 Air Mark Screw, for Flange Sockets)																													
Hole Identification -S16 (With M316 Air Mark Screw, for Flange Sockets)																													
-SC (With M312 Countersunk Air Mark Screw, for Flange Sockets with Countersunk Panel Installation)																													
-S10C (With M310 Countersunk Air Mark Screw, for Flange Sockets with Countersunk Panel Installation)																													

Note:

1. In the model naming of the national military standard GJB599A and the U.S. military standard MIL-DTL-38999K, except for the different main designations, the rest are completely the same. The main designation of GJB599A is "J599", and that of MIL-DTL-38999K is "D38999", and they are interchangeable. In the model naming of the national military standard GJB599A and the U.S. military standard MIL-DTL-38999K, except for the different main designations, the rest are completely the same. The main designation of GJB599A is "J599", and that of MIL-DTL-38999K is "D38999", and they are interchangeable.
2. Identifiers A and B are used to indicate that the electrical connector uses contacts (such as shielded, coaxial, optical fiber contacts, etc.) that are different from the non-standard configuration of GJB1611. Such contacts need to be ordered separately. For specific model specifications, see "Special Contacts for GJB599III Series Selection".
3. For details about the sealing caps, tail accessories, and flange rubber gaskets compatible with this series of products, please refer to the following text.
4. When there is a high oil resistance requirement, the connector sealing material is fluorosilicone rubber, and "C1" is added at the end of the original model (e.g.: J599/20FE35PNC1).
5. When the product needs to be equipped with a conductive flange rubber gasket, add "C2" or (C2) at the end of the product model; when the product needs to be equipped with a conductive O-ring, add "C5" or (C5)" at the end of the product model, such as J599/20FE35PNC2, J599/24FE35PNC5. Among them, (C2) and (C5) are not printed on the product model marking, while C2 and C5 without parentheses are printed on the product model.
6. When fuses are installed in plug sockets, Φ0.5 soft stainless steel wire is used for the fuses.

[Model Marking Example]

J599/20KB35PN-H

It is a J599 series flange socket with stainless steel passivated housing plating, housing B, contact arrangement 35, pin contacts (weld type), and key position N. Welded contacts are only applicable to welded connectors.

J599/20FTB35PN-S

It is a J599 series flange socket with aluminum alloy plated with nickel housing plating, housing B, contact arrangement 35, pin contacts, key position N (crimp type), and equipped with M3*12 air mark screws, flat washers, and spring washers.

GJB599 Series III (MIL-DTL-38999 Series III) Electrical Connector

Crimp Contact

Contact Specification	Diameter (mm)	Pin Color Code	Socket Color Code	Inner Diameter of Crimp Sleeve (mm)	Outer Diameter of Crimp Sleeve (mm)	Adapted Wire Cross-Section (mm ²)	Adapted American Wire Gauge (AWG)	Adapted Wire Insulation Outer Diameter (mm)	Removal Tool Code	Crimp Tool
22D	φ0.76	Orange-Blue-Black	Orange-Yellow-Gray	0.85	1.20	1.20	0.08 0.125 0.2 0.3	28 26 24 22	M81969 /14-01	YJQ-02
20#	φ1.00	Orange-Blue-Orange	Orange-Green-Brown	1.17	1.78	1.78	0.2 0.3 0.5	24 22 20 20	M81969 /14-10	YJQ-02 XCXY-01
16#	φ1.60	Orange-Blue-Yellow	Orange-Green-Red	1.68	2.62	2.62	0.5 0.8 1.0 1.2	20 18 16	M81969 /14-03	XCXY-01
12#	φ2.40	Orange-Blue-Green	Orange-Green-Orange	2.49	3.84	3.84	2.0 3.0	14 12	M81969/ 14-04	XCXY-01
10#	φ3.15	Green-Red-Gray	Green-Orange-Purple	3.40	4.65	4.65	4.8	10	M81969/ 14-05	YTQ
8#	φ3.6	—	—	4.55	6.4	6.4	8.37	8	M81969/ 14-12	YTQ

Welded Contact

Welded Contact Specification	Inner Diameter of Welding Cup	Maximum Adapted Wire Gauge (AWG)
22D	φ0.9	22
20#	φ1.1	20
16#	φ1.9	16
12#	φ2.9	12
10#	φ3.6	10
8#	φ4.8	8

Key Position

[Socket Front View]

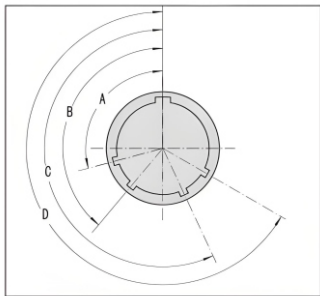

[Plug Front View]

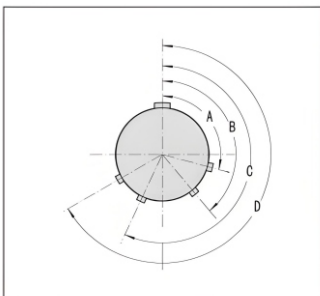

Housing No	MS Housing No	Angle	N	A	B	C	D	E
9	A	A°	105	102	80	35	64	91
		B°	140	132	118	140	155	131
		C°	215	248	230	205	234	197
		D°	265	320	312	275	304	240
11	B	A°	95	113	90	53	119	51
		B°	141	156	145	156	146	141
		C°	208	182	195	220	176	184
		D°	236	292	252	255	298	242
13	C	A°	95	113	90	53	119	51
		B°	141	156	145	156	146	141
		C°	208	182	195	220	176	184
		D°	236	292	252	255	298	242
15	D	A°	95	113	90	53	119	51
		B°	141	156	145	156	146	141
		C°	208	182	195	220	176	184
		D°	236	292	252	255	298	242
17	E	A°	80	135	49	66	62	79
		B°	142	170	169	140	145	153
		C°	196	200	200	200	180	197
		D°	293	310	244	257	280	272
19	F	A°	80	135	49	66	62	79
		B°	142	170	169	140	145	153
		C°	196	200	200	200	180	197
		D°	293	310	244	257	280	272
21	G	A°	80	135	49	66	62	79
		B°	142	170	169	140	145	153
		C°	196	200	200	200	180	197
		D°	293	310	244	257	280	272
23	H	A°	80	135	49	66	62	79
		B°	142	170	169	140	145	153
		C°	196	200	200	200	180	197
		D°	293	310	244	257	280	272
25	J	A°	80	135	49	66	62	79
		B°	142	170	169	140	145	153
		C°	196	200	200	200	180	197
		D°	293	310	244	257	280	272

GJB599 Series III (MIL-DTL-38999 Series III) Electrical Connector

[Plug]
(Knurling and locking hole types are for reference only)

	Housing No	MS Housing No	A max	Thread B	C max
	9	A	31.00	M12×1-6g	21.80
	11	B	31.00	M15×1-6g	25.00
	13	C	31.00	M18×1-6g	29.40
	15	D	31.00	M22×1-6g	32.40
	17	E	31.00	M25×1-6g	35.60
	19	F	31.00	M28×1-6g	38.50
	21	G	31.00	M31×1-6g	41.70
	23	H	31.00	M34×1-6g	44.90
25	J	31.00	M37×1-6g	48.00	

[Flange Socket]
(When the model is marked with -S, each socket is equipped with 5 navigation mark screws with locking holes, flat washers and spring washers)

	Housing No	MS Housing No	A max	B max	C max	D Thread	E	F	G	H	J	d1 min	d2 min
	9	A	20.90	10.80	2.50	M12×1-6g	23.80	18.26	15.09	3.25	5.49	16.66	13.11
	11	B	20.90	10.80	2.50	M15×1-6g	26.20	20.62	18.26	3.25	4.93	20.22	15.88
	13	C	20.90	10.80	2.50	M18×1-6g	28.60	23.01	20.62	3.25	4.93	23.42	19.05
	15	D	20.90	10.80	2.50	M22×1-6g	31.00	24.61	23.01	3.25	4.39	26.59	23.01
	17	E	20.90	10.80	2.50	M25×1-6g	33.30	26.97	24.61	3.25	4.39	30.96	25.81
	19	F	20.90	10.80	2.50	M28×1-6g	36.50	29.36	26.97	3.25	4.93	32.94	28.98
	21	G	20.10	11.50	3.20	M31×1-6g	39.70	31.75	29.36	3.25	4.93	36.12	32.16
	23	H	20.10	11.50	3.20	M34×1-6g	42.90	34.93	31.75	3.91	6.15	39.29	34.93
	25	J	20.10	11.50	3.20	M37×1-6g	46.00	38.10	34.93	3.91	6.15	42.47	37.69

GJB599 Series III (MIL-DTL-38999 Series III) Electrical Connector

[Nut Fastening Socket]

(When the model is marked with -S, the thread at the fastening nut is left-hand thread, and six locking holes are evenly distributed around the circumference of the fastening nut)

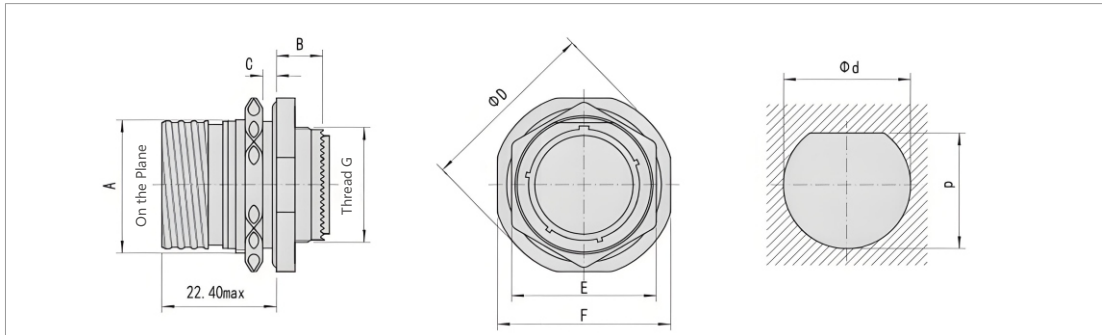

Housing No	MS Housing No	A	B max	C max	D max	E max	F	G Thread	d	p
9	A	16.50	9.90	3.20	30.50	24.00	27.00	M12×1-6g	17.70	16.99
11	B	19.30	9.90	3.20	35.20	27.00	31.80	M15×1-6g	20.88	19.53
13	C	24.00	9.90	3.20	38.40	32.00	34.90	M18×1-6g	25.58	24.26
15	D	27.20	9.90	3.20	41.60	36.00	38.10	M22×1-6g	28.80	27.53
17	E	30.40	9.90	3.20	44.80	37.00	41.30	M25×1-6g	31.98	30.68
19	F	33.40	9.90	3.20	49.30	41.00	46.00	M28×1-6g	35.15	33.86
21	G	36.50	9.90	3.20	52.70	46.00	49.20	M31×1-6g	38.28	37.06
23	H	39.70	9.90	3.20	55.90	50.00	52.40	M34×1-6g	41.50	40.24
25	J	42.80	9.90	3.20	59.00	51.23	55.60	M37×1-6g	44.68	43.41

[Socket with Printed Board Type Contacts of GJB599 Series III]

J599/24 Socket

J599/20 Socket

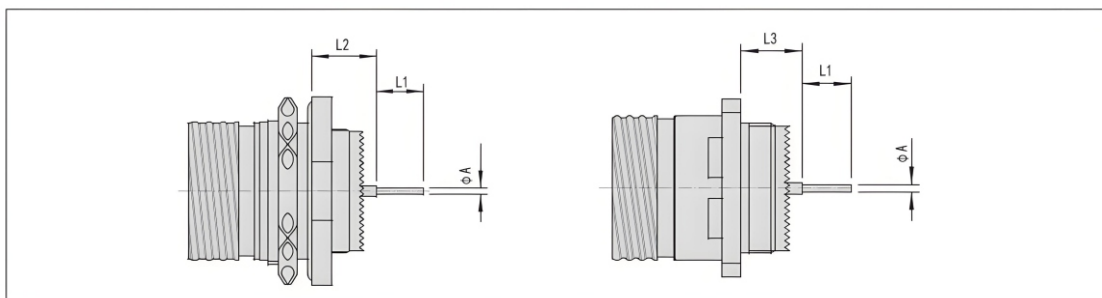

Specification of Printed Board Contact		L1	A
22D	Long Printed Board Contact	8.5	0.7
	Short Printed Board Contact	4.0	
20#	Long Printed Board Contact	8.5	0.7
	Short Printed Board Contact	5.1	
16#	Long Printed Board Contact	8.5	1.15
	Short Printed Board Contact	5.1	

GJB599 Series III (MIL-DTL-38999 Series III)

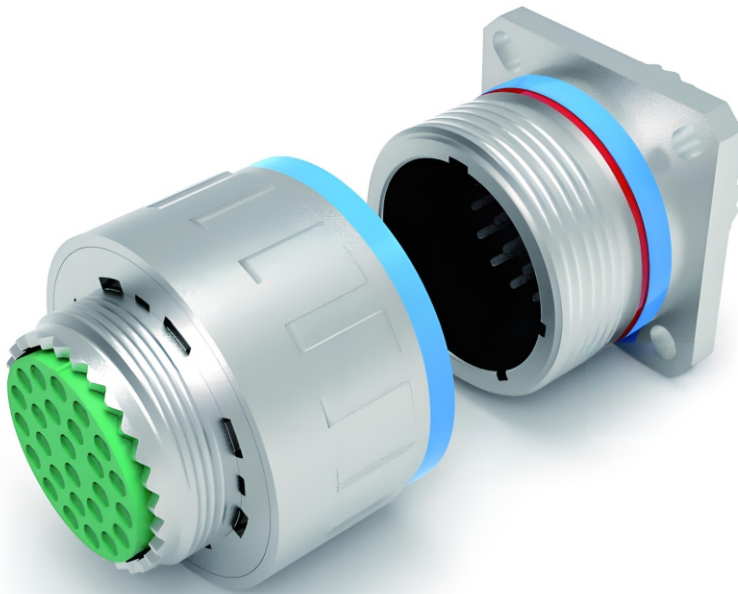

The pictures are for reference only

GJB599 Series III (MIL-DTL-38999 Series III)

Product Introduction

[Mechanical Properties]

- Shell: Composite material (about 30% of the weight of aluminum alloy shell)
- Plating: J – Chromium green passivation
M – Chemical nickel plating
- Insulator: Thermoplastic or thermosetting material
- Wire Seal and Seal Ring: Silicone rubber
- Contact: Copper alloy with gold plating
- Service Life: 1500 mating cycles
- Shock: 3ms half-sine wave, acceleration peak value 300g
- Vibration:
 - Sine: 60g, with temperature cycle and simulated accessories (36 hours)
 - Random: At high temperature, frequency 100~1000Hz, power spectral density 1g²/Hz, corresponding root mean square value 11.7g; At low temperature, frequency 100~1000Hz, power spectral density 5g²/Hz, corresponding root mean square value 49.5g

[Electrical Performance]

Withstand Voltage: V

Working Condition	Sea Level	At 21,000m Altitude
M	1300	800
N	1000	600
I	1800	1000
II	2300	1000

Note: Different contact arrangements have different working conditions. Please refer to the annotation at the upper right corner of the contact arrangement for details.

Contact Resistance and Rated Current of Contacts:

Contact Specification	Working Diameter (mm)	Contact Resistance (mΩ)	Rated Current (A)
22D	Φ0.76	≤12	5
20#	Φ1.00	≤5	7.5
16#	Φ1.60	≤2.5	13
12#	Φ2.40	≤1.5	23
10#	Φ3.15	≤1.0	40

[Environmental Performance]

- Salt Spray: 2000 hours
- Temperature Range:
 - Class J: -65°C ~ +175°C
 - Class M: -65°C ~ +200°C
- Sealing: Mated connectors meet the low-pressure immersion requirements of MIL-DTL-38999K
- Humidity: According to MIL-DTL-38999K: 10 cycles in 24 hours
- Fluid Resistance: Resistant to multiple fuels, coolants, and solvents

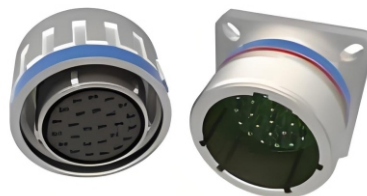

- Contact Retention Force: (Minimum force in Newtons)
 - 22D: 45N
 - 20#: 67N
 - 16#: 111N
 - 12#: 111N
 - 10#: 111N
 - 8#: 111N
- Insulation Resistance: ≥5000MΩ (500V DC)
- Shell Conductivity:
 - Class J: 3mΩ
 - Class M: 3mΩ
- Electromagnetic Interference Shielding:
 - At 100MHz~1GHz: Minimum attenuation of 85dB (Class J, Class M)
 - At 1GHz~10GHz: Minimum attenuation of 65dB (Class M), 50dB (Class J)
- 8# Twinaxial Contact:
 - Frequency Band: 0~20MHz
 - Rated Voltage: Up to 5000 V AC; Up to 125 V AC at maximum current
 - Voltage Drop: Inner and middle contacts ≤55mV at 1A; Outer contacts ≤75mV at 12A

GJB599 Series III (MIL-DTL-38999 Series III)

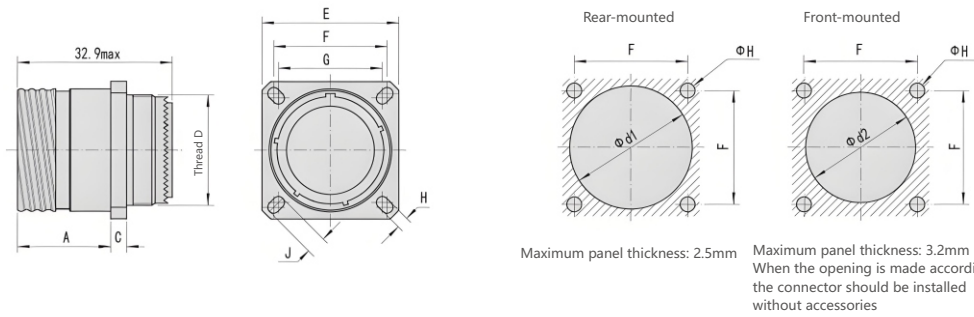

Housing No	MS Housing No	A max	C max	D Thread	E	F	G	H	J	d1 min	d2 min
9	A	19.80	3.65	M12×1-6g	23.80	18.26	15.09	3.25	5.49	16.66	13.11
11	B	19.80	3.65	M15×1-6g	26.20	20.62	18.26	3.25	4.93	20.22	15.88
13	C	19.80	3.65	M18×1-6g	28.60	23.01	20.62	3.25	4.93	23.42	19.05
15	D	19.80	3.65	M22×1-6g	31.00	24.61	23.01	3.25	4.39	26.59	23.01
17	E	19.80	3.65	M25×1-6g	33.30	26.97	24.61	3.25	4.39	30.96	25.81
19	F	19.80	3.65	M28×1-6g	36.50	29.36	26.97	3.25	4.93	32.94	28.98
21	G	19.00	3.65	M31×1-6g	39.70	31.75	29.36	3.25	4.93	36.12	32.16
23	H	19.00	4.35	M34×1-6g	42.90	34.93	31.75	3.91	6.15	39.29	34.93
25	J	19.00	4.35	M37×1-6g	46.00	38.10	34.93	3.91	6.15	42.47	37.69

[Nut Fastened Receptacle]

(When the model includes -S, the thread at the locking nut is left-hand thread, and six fuse holes are evenly distributed around the circumference of the locking nut)

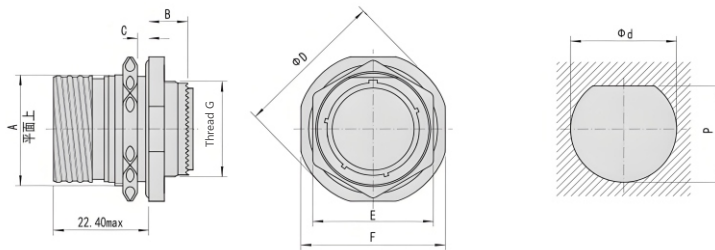

Housing No	MS Housing No	A	B max	C max	D max	E max	F	G Thread	d	p
9	A	16.50	9.90	3.20	30.50	24.00	27.00	M12×1-6g	17.70	16.99
11	B	19.30	9.90	3.20	35.20	27.00	31.80	M15×1-6g	20.88	19.53
13	C	24.00	9.90	3.20	38.40	32.00	34.90	M18×1-6g	25.58	24.26
15	D	27.20	9.90	3.20	41.60	36.00	38.10	M22×1-6g	28.80	27.53
17	E	30.40	9.90	3.20	44.80	37.00	41.30	M25×1-6g	31.98	30.68
19	F	33.40	9.90	3.20	49.30	41.00	46.00	M28×1-6g	35.15	33.86
21	G	36.50	9.90	3.20	52.70	46.00	49.20	M31×1-6g	38.28	37.06
23	H	39.70	9.90	3.20	55.90	50.00	52.40	M34×1-6g	41.50	40.24
25	J	42.80	9.90	3.20	59.00	51.23	55.60	M37×1-6g	44.68	43.41

GJB599 Series III (MIL-DTL-38999 Series III)

[Receptacle with Printed Board Type Contacts of GJB599 SeriesIII]

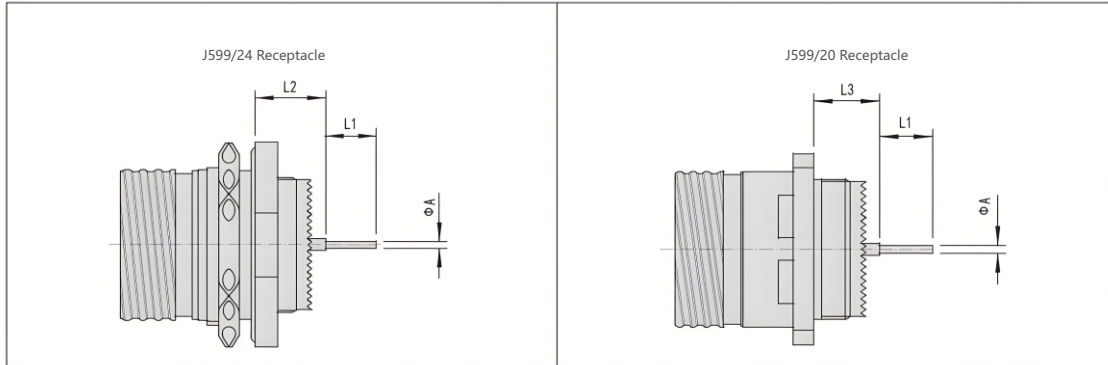

Specification of Printed Board Contact		L1	A
22D	Long Printed Board Contact	8.5	0.7
	Short Printed Board Contact	4.0	
20#	Long Printed Board Contact	8.5	0.7
	Short Printed Board Contact	5.1	
16#	Long Printed Board Contact	8.5	1.15
	Short Printed Board Contact	5.1	

Dimensions with Different Specification Contacts			Shell No. 09-11	Shell No. 13-15-17-19-21-23-25
L2	With 22D Pin	min	10.52	10.52
		max	11.46	11.46
	With 22D Socket	min	10.19	10.19
		max	11.46	11.46
	With 20# or 16# Pin, Socket	min	10.69	10.69
		max	11.63	11.63
L3	With 22D Pin	min	9.48	9.48
		max	10.58	10.58
	With 22D Socket	min	9.15	9.15
		max	10.58	10.58
	With 20# or 16# Pin, Socket	min	9.65	9.65
		max	10.75	10.75

GJB599 Series III (MIL-DTL-38999 Series III)

GJB599 Series III Contact Arrangement (Mating Face View of Pin Insulator)

Shell No 09 (A)	 35 M 6-22D	 98 I 3-20#	 02 I 2-20#	 03 I 3-20#	 10 I 1-12#	 11 I 1-16#	
11 (B)	 35 M 13-22D	 98 I 6-20#	 05 I 5-20#	 04 I 4-20#	 01 I 1-12#	 99 I 7-20#	 02 I 2-16#
	 15 N 4-22D 1-12#	 43 M 3-16#					
13 (C)	 35 M 22-22D	 98 I 10-20#	 08 I 8-20#	 04 I 4-16#	 12 N 1-12# 11-22D	 50 M 4-20# 1-10#	 60 I 4-16# 2-20#
	 03 I 3-16#	 02 I 2-12#	 05 I 1-16# 2-12#	 24 I 1-12#	 45 I 5-16#	 13 N 3-16# 10-22D	 26 M 2-12# 6-22D
	 99 I 3-16# 4-20#						
15 (D)	 35 M 37-22D	 19 I 19-20#	 18 I 18-20#	 05 I 5-16#	 97 I 8-20# 4-16#	 15 I 14-20# 1-16#	
	 02 I 2-12#	 14 N 8-22D 6-16#	 31 M 30-22D 1-12#	 38 I 4-12#	 48 I 8-16#	 12 M 2-12# 2-20# 8-22D	
	 23 M 3-16# 2-20# 18-22D						

Power Contact Component Specifications

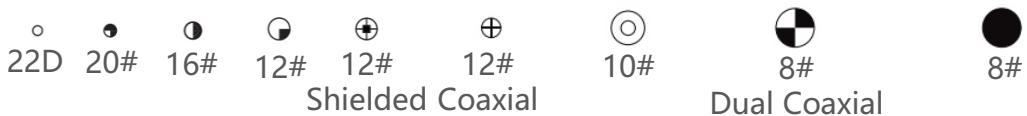

GJB599 Series III (MIL-DTL-38999 Series III)

17 (E)	35 M 55-22D 21-20# 2-16#	26 I 26-20#	06 I 6-12#	08 II 8-16#	99 I 21-20# 2-16#
	16 I 3-20# 1-16# 2-10#	27 I 7-12#	42 M 42-22D	12 N 9-22D 3-12# Shielded	03 N 2-10# 1-16#
	05 I 5-12#	21 N 17-22D 4-12#	30 N 3-10# 3-20#	09 I 5-16# 1-12# 3-20#	15 M 8-16# 3-20# 4-22D
	19 M 4-16# 11-20# 4-22D	20 I 2-20# 16-22D	21 N 4-12# 17-22D	51 M 10-16# 1-8# Dual Coaxial	99a N 4-16# 19-20#
19 (F)	35 M 66-22D	32 I 32-20#	11 II 11-16#	28 I 26-20# 2-16#	30 I 29-20# 1-16#
	45 M 67-22D	18 M 14-22D 4-8# Dual Coaxial	05 N 1-20# 4-10#	22 I 22-20#	08 M 8-12#
	10 I 7-16# 1-12# 2-10#	12 I 7-20# 1-16# 2-10#	96 I 9-12#	18a M 4-8# 14-22D	10a I 5-12# 5-16#

Power Contact Component Specifications

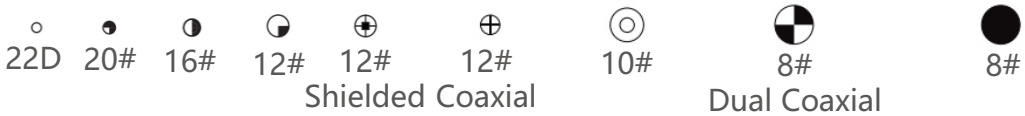

GJB599 Series III (MIL-DTL-38999 Series III)

GJB599 Series III Contact Arrangement (Mating Face View of Pin Insulator)

19 (F)	14 6-12# 8-20#	16 2-12# 14-16#	19 19-16#	22a 2-12# 6-16#, 14-22D	24 8-16# 4-20#, 8-22D
	28a 12-16# 16-22D	92 30-22D 2-8# Dual Coaxial	93 2-10# 6-20#, 24-22D		
21 (G)	35 79-22D	41 41-20#	16 16-16#	39 37-20# 2-16#	11 11-12#
	27 27-20#	25 25-20#	24 24-20#	29 26-20# 3-12# Coaxial	70 20-16#
	80 12-16#	15 13-20# 2-8# Dual Coaxial	02 65-22D	16 16-16#	39a 8-16# 31-22D
	61 6-16# 55-22D	70 20-16#			

Power Contact Component Specifications

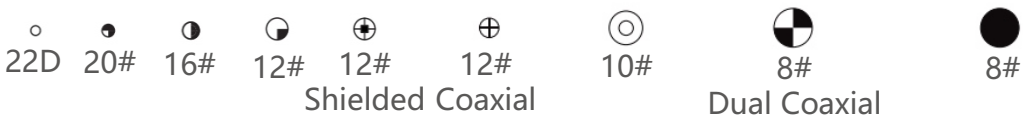

GJB599 Series III (MIL-DTL-38999 Series III)

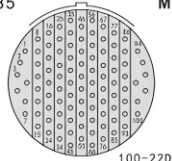
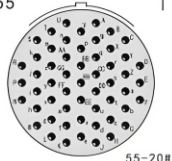
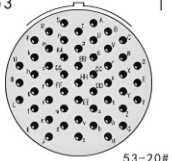
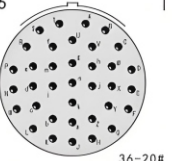
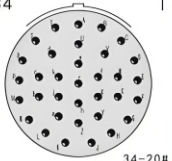
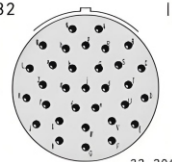
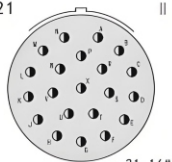
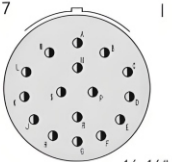
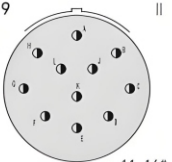
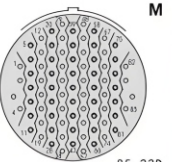
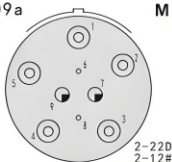
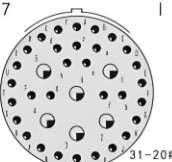
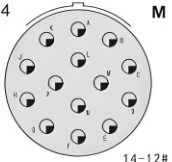
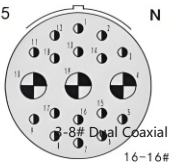
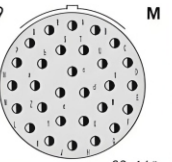
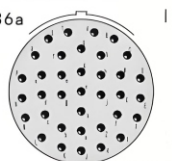
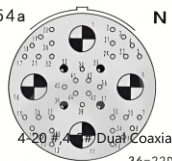
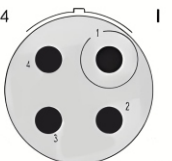
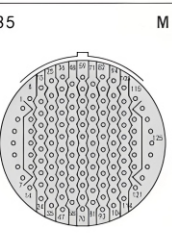
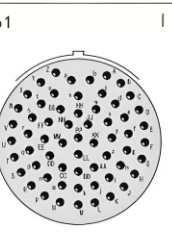
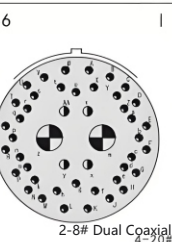
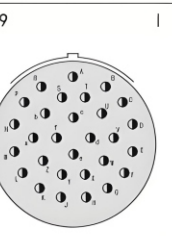
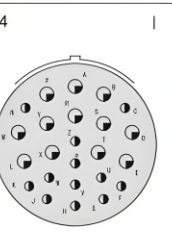
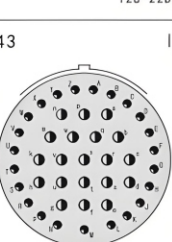
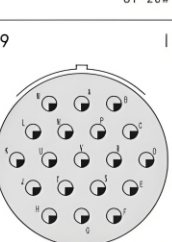
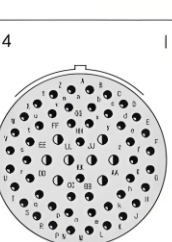
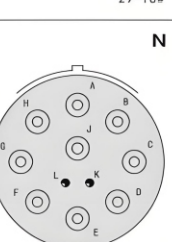
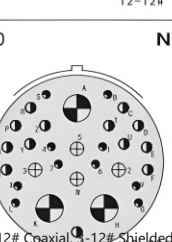
23 (H)	35 M  100-22D	55 I  55-20#	53 I  53-20#	36 I  36-20#	34 I  34-20#
	32 I  32-20#	21 II  21-16#	97 I  16-16#	99 II  11-16#	2 M  85-22D
	09a M  2-22D 2-12# 5-10#	37 I  31-20# 6-12#	14 M  14-12#	15 N  8-8# Dual Coaxial	29 M  29-16#
	36a I  36-20#	54a N  4-20#, 4-12# Dual Coaxial	04 I  4-8#		
25 (J)	35 M  128-22D	61 I  61-20#	46 I  2-8# Dual Coaxial 4-20# 4-16#	29 I  29-16#	24 I  12-16# 12-12#
	43 I  23-20# 20-16#	19 I  19-12#	04 I  48-20# 8-16#	11 N  2-20# 9-10#	20 N  1-12# Coaxial, 3-12# Shielded 3-8# Dual Coaxial

Power Contact Component Specifications

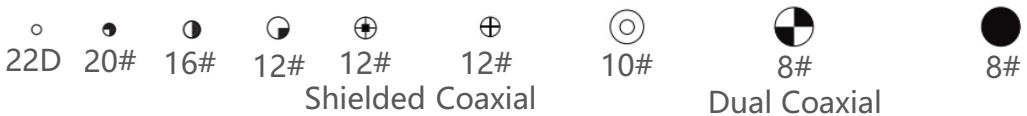

GJB599 Series III (MIL-DTL-38999 Series III)

GJB599 Series III Contact Arrangement (Mating Face View of Pin Insulator)

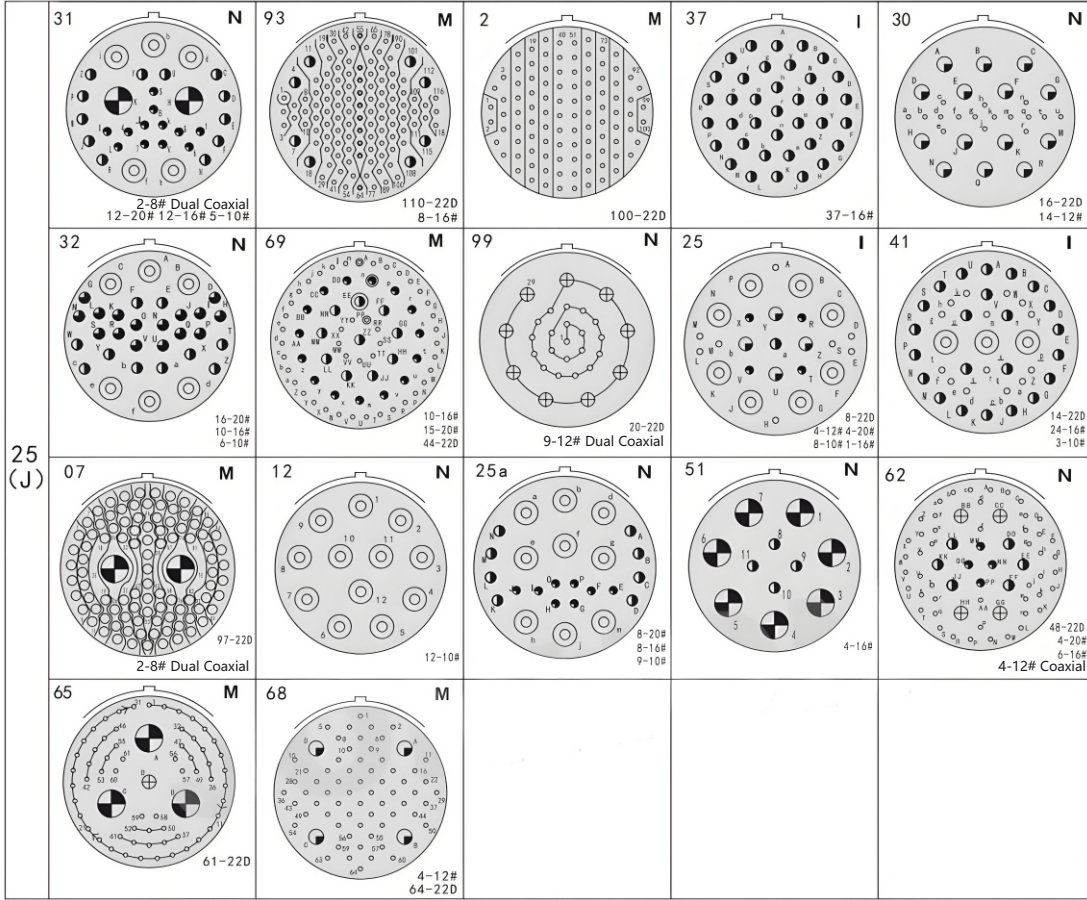

Power Contact Component Specifications

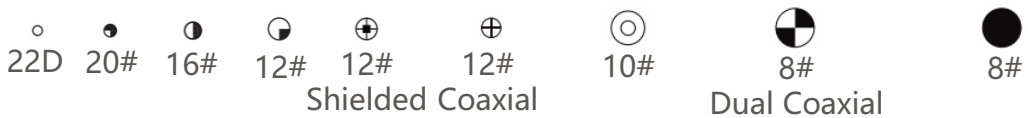

GJB599 Series III (MIL-DTL-38999 Series III)

Dimensions After Plug and Socket Mating

Flange Socket (J599/20) / Plug (J599/26)				Screw Fastening Socket (J599/24) / Plug (J599/26)						
Housing No		09	11	13	15	17	19	21	23	25
L1	max	53.2	53.2	53.2	53.2	53.2	53.2	52.4	52.4	52.4
L2	max	40.3	40.3	40.3	40.3	40.3	40.3	39.6	39.6	39.6
A	max	2.5	2.5	2.5	2.5	2.5	2.5	3.2	3.2	3.2
B	max	9.6	9.6	9.6	9.6	9.6	9.6	9.6	9.6	9.6

Plug and Socket Sealing Cap

[Model Naming]

Series Main Name	J599/	32	F	09	N
Type	32 - Plug Sealing Cap (Corresponding to US Military Standard Part Number D38999/32) 33 - Socket Sealing Cap (Corresponding to US Military Standard Part Number D38999/33)				
Shell Plating	W - Cadmium Green Plated Aluminum Shell J - Cadmium Plated Composite Shell F - Electroless Nickel Plated Aluminum Shell M - Electroless Nickel Plated Composite Shell K - Stainless Steel Passivation				
Shell Number	09-11-13-15-17-19-21-23-25				
Chain Type	R - Stainless Steel Wire Rope Tab (For Flange Socket) N - Stainless Steel Wire Rope Loop (For Screw Fastening Socket) C - Copper Wire Rope Tab (For Flange Socket) S - Copper Wire Rope Loop (For Screw Fastening Socket)				

Note: The sealing cap should be ordered separately and is not supplied with the connector.

[Overall Dimensions]

		Plug Sealing Cap J599/32 (D38999/32)				Socket Sealing Cap J599/33 (D38999/33)				
Housing No		09	11	13	15	17	19	21	23	25
A	max	22.86	25.40	30.48	33.02	36.83	39.37	43.18	44.45	48.26
B	max	12.92	17.78	19.27	22.60	25.62	28.95	31.97	34.03	38.32
C	max	22.86	27.86	30.48	31.75	36.83	38.10	41.91	44.45	48.26
D	max	17.78	21.33	25.62	28.95	31.97	35.30	38.32	41.65	44.45
L	max	127.00	127.00	127.00	127.00	127.00	127.00	127.00	127.00	127.00

GJB599 Series III (MIL-DTL-38999 Series III)

Anti-loosening Socket Sealing Cap

[Model Naming]

Series Main Name	J599/	33A	F	09	N
Type	33A - Anti-loosening Socket Seal				
Shell Plating	W - Cadmium Green Plated Aluminum F - Electroless Nickel Plated Aluminum Alloy K - Stainless Steel Passivation J - Cadmium Green Plated Composite Material		FT - Cadmium Plated Alloy with Forged Nickel Surface M - Nickel Plated Composite Material		
Shell Number	09-11-13-15-17-19-21-23-25				
Chain Type	R - Stainless Steel Wire Rope Tab (For Flange Socket) N - Stainless Steel Wire Rope Loop (For Screw Fastening Socket)				

Note: The sealing cap should be ordered separately and is not supplied with the connector.

Housing No		09	11	13	15	17	19	21	23	25	
A	max	21.8	25.0	29.4	32.5	35.6	38.6	41.7	44.9	48.0	
L	max	127.0	127.0	127.0	127.0	127.0	127.0	127.0	127.0	127.0	

Standard Rear Accessories (Suitable for GJB599 Series III Electrical Connectors)

This type of accessory complies with the national military standard GJB 1784 (equivalent to the US military standard MIL-C-85049).

- Note: (1) "J1784" and "J1784 A" mentioned in the following accessory models are identical and have no difference.
 (2) When using the accessories, at least one of the following anti-loosening measures should be taken:
 ① Pass the fuse through the safety hole for anti-loosening;
 ② Apply thread lock adhesive to the threads at the rear of the product and then tighten the connecting nut for anti-loosening;
 ③ Use a heat shrink tube to shrink the entire accessory for anti-loosening.
 (3) For accessories with set screws, apply thread lock adhesive to the set screws before tightening them.
 (4) If the product matched with the cable accessory is equipped with contact 8, please select a longer cable accessory such as J1784/38H or J1784/18 to avoid interference between the contact locator and the cable accessory.
 (5) The following table lists the correspondence between GJB599 series welded and crimped products and matching cable accessories, as well as the functional classification of cable accessories. Due to the large number of modified products and accessories of our company at this stage, they cannot be listed one by one. The content of this table is for reference only. Please contact our company for detailed information.

Housing No	Functional Type of Matching Cable Accessory	Model of Matching Cable Accessory	
GJB599 Series III Crimp-Type Connector	Accessory that Neither Clamps Cable nor Provides Shielding	1. J1784/14 1. J1784/38	
	Accessory that Clamps Cable but Does Not Provide Shielding	2. J1784/39 3. J1784/16	
		4. J1784/91-xxJ (Composite Material) 5. J1784/92-xxJ (Composite Material)	
		1. J1784/20 2. J1784/20-xxJ (Composite Material)	
	Accessory that Provides Shielding but Does Not Clamp Cable	3. J1784/69 4. J1784/88 5. J1784/90	
		6. JY599III-FJA00 7. JY599III-FJA90 8. JY599III-xxFJB00F 9. JY599IIIxxFJC00 10. JY599IIIxxFJE00	
		Accessory that Both Clamps Cable and Provides Shielding	1. J1784/38-xxNB 2. J1784/18 Series

GJB599 Series III (MIL-DTL-38999 Series III)

Housing No	Functional Type of Matching Cable Accessory	Model of Matching Cable Accessory
GJB599 Series III Weld-Type Connector	Accessory that Neither Clamps Cable nor Provides Shielding	1. J1784/14
	Accessory that Clamps Cable but Does Not Provide Shielding	1. J1784/38H
		2. J1784/16H
		3. J1784/91H-x×J (Composite Material)
	Accessory that Provides Shielding but Does Not Clamp Cable	1. J1784/20
		2. J1784/69
		3. J1784/88
		4. J1784/90
	Accessory that Both Clamps Cable and Provides Shielding	5. JY599III-FJA00
		6. JY599III-FJA90
	Accessory that Both Clamps Cable and Provides Shielding	1. J1784/18 Series

Series Main Name	J1784	38-	15	N
Type	14 – Tail Nut 38 – Straight Cable Clamp	16 – Angled Cable Clamp 39 – Angled Cable Clamp	20 – Shielded Rear Accessory 69 – Heat Shrink Sleeve Type Rear Accessory	
Shell Number	09–11–13–15–17–19–21–23–25			
Shell Plating	W – Cadmium Plated Military Green N – Electroless Nickel Plating S – Stainless Steel Passivation FT – Aluminum Alloy Plated with Satin Nickel TA – Titanium Alloy			

[J1784/14 – Tail Nut] (Accessory that Neither Clamps Cable nor Provides Shielding)

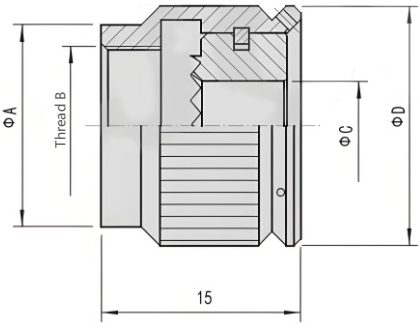
	Shell Number	A	Thread B	C	D
	09	15.2	M12×1	7.9	19
	11	18.2	M15×1	10.8	22
	13	21.2	M18×1	13.6	25.1
	15	25.1	M22×1	16.9	29
	17	28.1	M25×1	20.1	32.1
	19	31.1	M28×1	22.1	35.1
	21	34.0	M31×1	25.2	38.1
	23	37.0	M34×1	28.3	41.1
	25	40.0	M37×1	31.6	44.1

Anti-rotation accessory, which tightly seals the wire body to ensure the environmental resistance of the connector. It cannot clamp the cable and is used in general environmental conditions.

[J1784/20 – Shielded Rear Accessory] (Shielded Cable Non-Clamping Accessory)

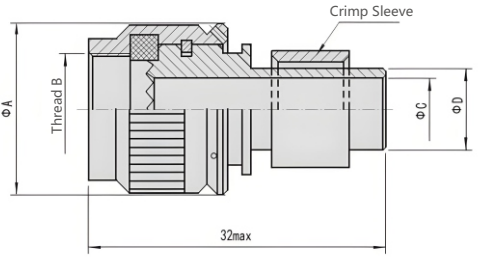
	Shell Number	A	Thread B	C	D	Selection of Pressure Block Mark
	09	19	M12×1	6.55	8.81	08
	11	22	M15×1	8.63	12.65	10
	13	25.1	M18×1	10.90	12.95	12
	15	29	M22×1	14.10	16.00	14
	17	32.1	M25×1	17.25	19.30	16
	19	35.1	M28×1	20.40	22.61	18
	21	38.1	M31×1	23.60	25.65	20
	23	41.1	M34×1	26.40	28.70	22
	25	44.1	M37×1	28.40	30.53	24

Anti-rotation and clamping shielded mesh accessory. It can tightly clamp the wire body, provide the connection function between the shielded mesh and the rear accessory, ensure the environmental resistance and electromagnetic shielding performance of the connector. It cannot clamp the cable and is used in occasions where the cable is subjected to small tension.

GJB599 Series III (MIL-DTL-38999 Series III)

[J1784/69 – Heat Shrink Sleeve Type Rear Accessory] (Shielded Cable Non-Clamping Accessory)

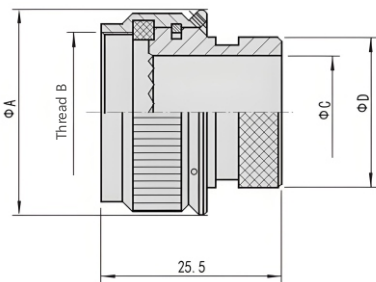
	Shell Number	A	Thread B	C	D
	09	19.0	M12×1	6.7	13.5
	11	22.0	M15×1	9.9	15.3
	13	25.1	M18×1	12.8	19.6
	15	29.0	M22×1	16.0	21.2
	17	32.1	M25×1	19.2	24.4
	19	35.1	M28×1	21.4	26.4
	21	38.1	M31×1	24.6	30.9
	23	41.1	M34×1	27.7	34.4
	25	44.1	M37×1	30.9	36.6

Anti-rotation and tight shielding mesh accessory. It can tightly seal the wire and provide the connection function between the shielding mesh and the tail accessory, ensuring the connector's environmental resistance and electromagnetic shielding performance. It cannot clamp the cable and is used in situations where the cable is under small tensile force.

Note: The heat-shrinkable sleeve is purchased separately.

[J1784/38 Straight Cable Clamp] (When (S) and (M) are added after the model, the outlet diameter D changes accordingly. (S) and (M) are reflected in the product marking. For example, the outlet diameter of J1784/38-13W (M) is 4.83 ~ 6.58.)

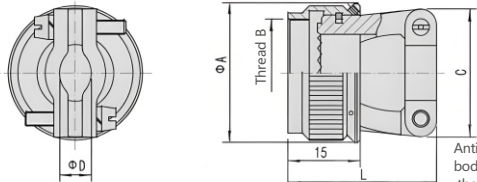
	<p>Anti-rotation and cable clamping cable accessories can compact the wire body and clamp the cable, ensure the environmental resistance of the connector, and be used for cable tension splicing.</p>									
	Shell Number	A max	Thread B	C max	With (S) After Model		With (M) After Model		Normal Model	
				D	Screw Length	D	Screw Length	D	Screw Length	
09	19	M12×1	20.0	—	—	—	—	2.49~5.94	M3.5×12	27.0
11	22	M15×1	21.0	—	—	—	—	3.87~5.94	M3.5×12	28.5
13	25.1	M18×1	23.4	4.83	M3.5×12	4.83~6.58	M3.5×14	4.83~8.33	M3.5×16	30.0
15	29	M22×1	26.6	6.60	M3.5×12	6.60~9.11	M3.5×14	6.60~11.61	M3.5×16	31.5
17	30	M25×1	30.6	7.19	M3.5×12	7.19~11.40	M3.5×16	7.19~15.60	M3.5×20	33.5
19	35.1	M28×1	34.0	8.26	M4×14	8.26~13.16	M4×18	8.26~16.10	M4×22	36.6
21	38.1	M31×1	35.8	8.71	M4×14	8.71~13.61	M4×18	8.71~17.73	M4×24	39.8
23	41.1	M34×1	39.0	9.68	M4×14	9.68~16.58	M4×20	9.68~20.90	M4×26	42.9
25	44.1	M37×1	40.6	10.62	M4×14	10.62~17.42	M4×20	10.62~21.66	M4×26	45.0

[J1784/38H - Welding Type Straight Cable Clamp] (Cable Clamping Unshielded Accessory)

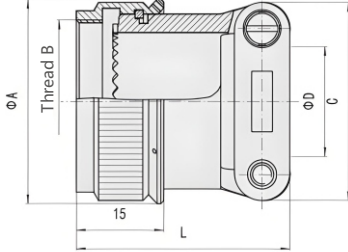
	Shell Number	A max	Thread B	C max	D min	D max	L max
	09	19.0	M12×1	20.0	2.49	5.94	27.0
	11	22.0	M15×1	21.0	3.87	5.94	28.5
	13	25.1	M18×1	23.4	4.83	8.33	30.0
	15	29.0	M22×1	26.6	6.60	11.61	31.5
	17	32.1	M25×1	30.6	7.19	15.60	33.5
	19	35.1	M28×1	34.0	8.26	16.10	36.6
	21	38.1	M31×1	35.8	8.71	17.73	39.8
	23	41.1	M34×1	39.0	9.68	20.90	42.9
	25	44.1	M37×1	40.6	10.62	21.66	45.0

It has the same function as J1784/38, is matched with welded products, and is also applicable to the GJB599111 series power supply series.

GJB599 Series III (MIL-DTL-38999 Series III)

[J1784/39 - Angled Cable Clamp] (Clamping Unshielded Cable Attachment)

	Shell Number	A max	Thread B	C max	D		E max	L max
					min	max		
<p>Anti-rotation, 90° cable clamping accessory. It can tightly seal the shell and clamp the cable at 90°, ensuring the environmental performance of the connector, and is used in cable tension applications.</p>	09	19.0	M12×1	20.0	2.85	6.71	21	25.9
	11	22.0	M15×1	21.5	6	9.96	26.5	29.2
	13	25.1	M18×1	23.0	8.45	12.85	31.5	32
	15	29.0	M22×1	25.0	12	16.03	36.5	35.2
	17	32.1	M25×1	27.0	11.1	19.2	31	36.4
	19	35.1	M28×1	28.5	13.75	21.46	37	40.7
	21	38.1	M31×1	29.5	19.3	24.64	35	43.8
	23	41.1	M34×1	31.0	21.4	27.81	35	43
	25	44.1	M37×1	33.0	23.5	30.99	37	44.2

[J1784/16 - Angled Cable Clamp] (Clamping Unshielded Cable Attachment)

	Shell Number	A max	Thread B	C max	D		E max	L max
					min	max		
<p>Anti-rotation, 90° cable clamping accessory has the same function as the J1784/39 accessory. Compared with J1784/39, its cable outlet diameter (D) is larger.</p>	09	19.0	M12×1	20.0	2.85	6.71	21	25.9
	11	22.0	M15×1	21.5	6	9.96	26.5	29.2
	13	25.1	M18×1	23.0	8.45	12.85	31.5	32
	15	29.0	M22×1	25.0	12	16.03	36.5	35.2
	17	32.1	M25×1	27.0	11.1	19.2	31	36.4
	19	35.1	M28×1	28.5	13.75	21.46	37	40.7
	21	38.1	M31×1	29.5	19.3	24.64	35	43.8
	23	41.1	M34×1	31.0	21.4	27.81	35	43
	25	44.1	M37×1	33.0	23.5	30.99	37	44.2

[TJ1784/69-XXB] (Shielded Cable Clamping Attachment)

Series Main Name	J1784/ 38- 15 N B
Type	69 - Straight Shielded Attachment (Shielded Cable Clamping Attachment)
Shell Number	09-11-13-15-17-19-21-23-25
Shell Plating	W – Cadmium-plated Olive Drab; N – Electroless Nickel Plating; S – Stainless Steel Passivation; FT – Aluminum Alloy Plated with Forged Nickel; TA – Titanium Alloy
Category Identifier	B

Example of model marking: TJ1784/69-15NB, shell number 15, aluminum alloy with electroless nickel plating.

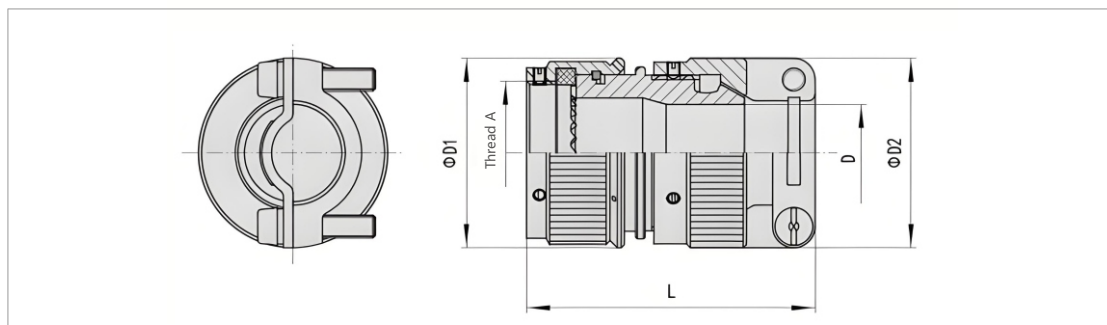

GJB599 Series III (MIL-DTL-38999 Series III)

Shell Number	Thread A	D1	D2	D	L
09	M12×1	19.0	20.0	7.0	40.0
11	M15×1	22.0	22.5	9.7	41.0
13	M18×1	25.1	25.9	12.8	41.0
15	M22×1	29.0	29.0	14.9	46.0
17	M25×1	32.0	32.5	18.0	46.0
19	M28×1	35.0	36.6	20.0	47.5
21	M31×1	38.0	39.5	23.2	52.5
23	M34×1	41.1	42.0	26.3	57.5
25	M37×1	44.1	45.0	28.9	58.5

[J1784/18-xN] (Shielded Cable Clamping Attachment)

Series Main Name	J1784/ 18- 25 N 09 A
Type	18-Straight Shielded Cable Clamp
Shell Number	See Table 1
Shell Plating	N – Electroless Nickel Plating; W – Cadmium-plated Olive Drab; S – Stainless Steel Passivation; FT – Aluminum Alloy Plated with Forged Nickel; TA – Titanium Alloy
Cable Outlet Diameter Number	Please select in combination with Table 1 and Table 2
Length Code	See Table 3

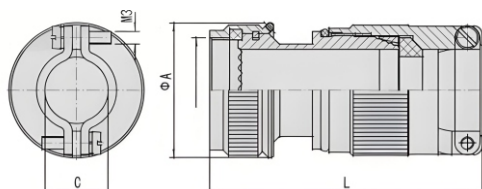

Anti-rotation, shielded mesh clamping and cable clamping accessory. It can tightly seal the cable body, provide the function of connecting the shielded mesh with the tail accessory, ensure the high environmental resistance and electromagnetic shielding performance of the connector, and is used in harsh environment scenarios.

This cable accessory has different length options, suitable for scenarios that require longer lengths such as low and high frequency, and it is recommended to use finished cables with this accessory.

Table 1

Shell Number	Optional outlet diameter codes for each shell number	A	Thread B
09	01-02	19	M12×1
11	01-03	22	M15×1
13	02-04	25.1	M18×1
15	02-05	29	M22×1
17	02-06	32	M25×1
19	03-07	35	M28×1
21	03-08	38	M31×1
23	03-09	41.1	M34×1
25	04-10	44.1	M37×1

Table 2

Cable Outlet Diameter Number	Applicable Cable Diameter Range(C)
01	1.57-3.18
02	3.18-6.35
03	6.35-9.53
04	9.53-12.7
05	12.7-15.88
06	15.88-19.05
07	19.05-22.23
08	22.23-25.4
09	25.4-28.58
10	28.58-31.75

Table 3

Shell Number	Length Code	L
09-25	Standard (Omitted if not marked)	64.4
09-25	A	89.8
15-25	B	115.2
21-25	C	140.6

GJB599 Series III (MIL-DTL-38999 Series III)

GJB599 Series III (MIL-DTL-38999 Series III)

Composite Material Tail Accessory

[Model Naming]

Series Main Name	J1784	91-	15	J	-S
Type	20-Shielded Tail Accessory; 91-Straight Cable Clamp (Only for Crimp Products); 91H-Straight Cable Clamp (For Soldering and Crimp Products); 92-Angled Cable Clamp				
Shell Number	09-11-13-15-17-19-21-23-25				
Shell Plating	J – Cadmium-plated Olive Drab; M – Electroless Nickel Plating				
Safety Hole Mark	-S (With 3 Safety Holes on the Connecting Nut)				

[J1784/20××J (Composite Material)] (Shielded Non-Cable Clamping Accessory)

<p>Not compatible with soldered electrical connectors, only compatible with crimped electrical connectors</p>		Shell Number	A	Thread B	C	D
		09	21.8	M12×1	6.73	12.65
		11	25	M15×1	8.71	12.95
		13	29.5	M18×1	11.1	16
		15	32.5	M22×1	14.27	19.3
		17	35.5	M25×1	17.45	22.61
		19	38.5	M28×1	20.62	25.65
		21	41.5	M31×1	23.8	28.7
		23	45	M34×1	26.57	30.53
		25	48	M37×1	28.58	34.52

[J1784/91-××J (Composite Material)] (Cable Clamping Non-Shielded Accessory)

<p>Not compatible with soldered electrical connectors, only compatible with crimped electrical connectors</p> <p style="font-size: small;">Schematic Diagram of Safety Hole (For Reference When the Model Includes -S)</p>		Shell Number	A max	Thread B	C max	D min	D max	L max
		09	21.8	M12×1	20.0	4.00	5.94	27.0
		11	25	M15×1	20.0	4.00	5.94	28.5
		13	29.5	M18×1	23.4	4.83	8.33	30.0
		15	32.5	M22×1	26.6	6.60	11.61	31.5
		17	35.5	M25×1	30.6	7.19	15.60	33.5
		19	38.5	M28×1	34.0	8.26	16.10	36.6
		21	41.5	M31×1	35.8	8.71	17.73	39.8
		23	45	M34×1	39.0	9.68	20.90	42.9
		25	48	M37×1	40.6	10.62	21.66	45.0

[J1784/91H-××J (Soldering Type, Composite Material)] (Cable Clamping Non-Shielded Accessory)

<p>Compatible with both soldered and crimped electrical connectors</p>		Shell Number	A max	Thread B	C max	D min	D max	L max
		09	21.8	M12×1	20.0	4.00	5.94	27.0
		11	25	M15×1	20.0	4.00	5.94	28.5
		13	29.5	M18×1	23.4	4.83	8.33	30.0
		15	32.5	M22×1	26.6	6.60	11.61	31.5
		17	35.5	M25×1	30.6	7.19	15.60	33.5
		19	38.5	M28×1	34.0	8.26	16.10	36.6
		21	41.5	M31×1	35.8	8.71	17.73	39.8
		23	45	M34×1	39.0	9.68	20.90	42.9
		25	48	M37×1	40.6	10.62	21.66	45.0

GJB599 Series III (MIL-DTL-38999 Series III)

[J1784/92-××J (Composite Material)] (Cable Clamping Non-Shielded Accessory)

<p>Not compatible with soldered electrical connectors, only compatible with crimped electrical connectors</p> <p>Schematic Diagram of Safety Hole (For Reference When the Model Includes -S)</p>	Shell Number	A max	Thread B	C max	D min	D max	L max
	09	21.8	M12×1	20.6	2.49	5.94	29.5
	11	25	M15×1	22.0	3.87	5.94	29.5
	13	29.5	M18×1	23.6	4.83	8.33	31.9
	15	32.5	M22×1	25.2	6.60	11.61	35.1
	17	35.5	M25×1	26.8	7.19	15.60	39.1
	19	38.5	M28×1	31.3	8.26	16.10	41.5
	21	41.5	M31×1	32.9	8.71	17.73	43.3
	23	45	M34×1	34.5	9.68	20.90	46.5
	25	48	M37×1	36.1	10.62	21.66	47.1

Special Tail Accessories

This type of tail accessory is particularly suitable for clamping shielded cables with shielding nets, and is divided into two major categories: straight type and bent type. This accessory can be optionally equipped with a Ti-Ni alloy memory ring with alloy memory. By heating, it shrinks to tightly clamp the shielding net at the tail of the accessory, truly achieving 360° electromagnetic shielding.

Note: Heating and shrinking method of Ti-Ni alloy memory ring: It can be heated with a hot air gun, which takes about 45 seconds to 1 minute. When the temperature indicator on the memory ring changes from green to black, the memory ring has finished shrinking. At this time, the temperature of the ring is about 165°C, and heating should be stopped. Note that the memory ring should be heated evenly during heating.

[Model Naming]

J1784/88, J1784/90 Tail Accessories (Shielded Non-Clamping Cable Accessories)

Series Main Name	J1784/	11	N	A	-05				
Type	88-Straight, 90-Bent								
Shell Number	09	11	13	15	17	19	21	23	25
Compatible Series III Shell Number	A	B	C	D	E	F	G	H	J
Shell Plating	W - Cadmium-plated Military Green N - Electroless Nickel Plating S - Stainless Steel Passivation FT - Aluminum Alloy Plated with Forged Nickel TA - Titanium Alloy (Only for Type 88)								
Ti-Ni Ring	No Mark - No Ti-Ni Ring A - Optional Ti-Ni Ring								
Outlet Diameter or Ti-Ni Ring Specification	When there is no Ti-Ni ring, mark the outlet diameter When selecting Ti-Ni ring, mark the specification of Ti-Ni ring								

GJB599 Series III (MIL-DTL-38999 Series III)

GJB599 Series III (MIL-DTL-38999 Series III)

JY599 III-FJA00, JY599 III-FJA90 External Shielding Tail Accessories (Shielded Non-Clamping Cable Accessories)

Series Main Name	Jy599/ III 15 FJA 00 F A -05
Series Code	III
Shell Number	09-11-13-15-17-19-21-23-25
Accessory Type	FJA, FJB, FJC, FJE
Type	00 – Straight Tail Accessory 90 – 90° Bent Accessory
Shell Plating	W – Cadmium-plated Military Green F – Electroless Nickel Plating K – Stainless Steel Passivation FT – Aluminum Alloy Plated with Forged Nickel TA – Titanium Alloy (Only for Type 00)
Ti-Ni Ring	No Mark – No Ti-Ni Ring A – Optional Ti-Ni Ring (Only for FJA, FJC)
Outlet Diameter or Ti-Ni Ring Specification	Mark the outlet diameter when there is no Ti-Ni ring Mark the specification of Ti-Ni ring when selecting Ti-Ni ring

Note:

This type of accessory is used in harsh environments where frequent disassembly is not required. It can achieve internal and external shielding. If steel strapping is needed, the steel strap and strapping pliers need to be ordered separately. The steel strapping is "Stainless Steel Strapping A31189 (07-08-221)", and the strapping pliers are "Steel Strapping Pliers A30199 TIE-DEX II (14-04-3216)". J1784/88, J1784/90 are the same as JY599 III-FJA00 and JY599 III-FJA90, only differing in model naming.

[Model Naming]

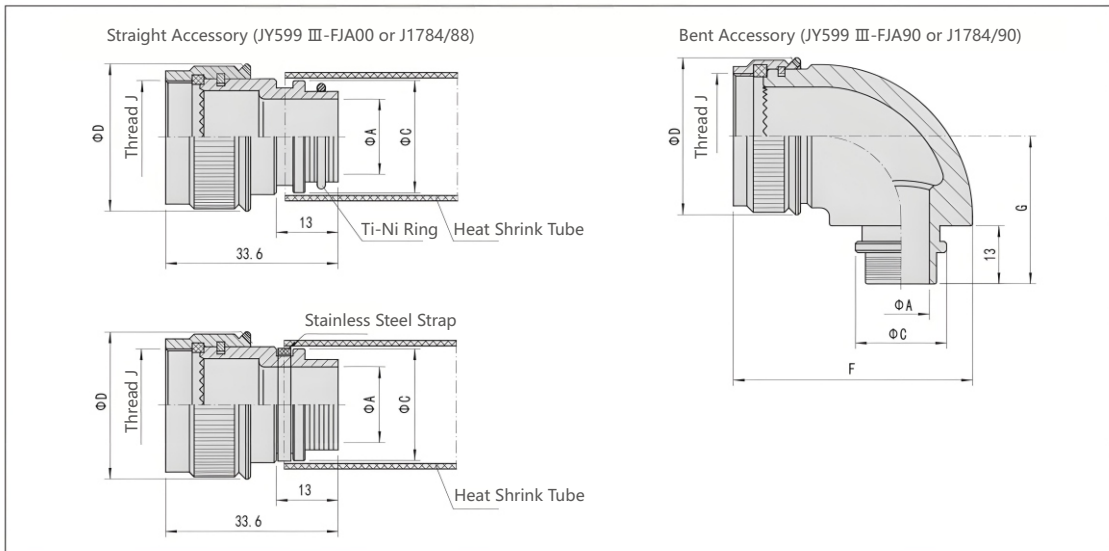

GJB599 Series III (MIL-DTL-38999 Series III)

Serial Number	Shell Serial Number	Ti-Ni Ring Specification	Shield Mesh Specification (Diameter of Tinned Copper Wire)	Outlet Diameter ΦA		C		F	D	G	Thread J
				Straight Type	Bent Type	Straight Type	Bent Type				
1	09	TR-04	6×10 (0.15~0.20)	6.3	6.3	14	14	38.2	19	26	M12×1-6H
		TR-05	10×16 (0.15~0.20)	7.9	7.9	15.5	15				
		TR-06	10×16 (0.15~0.20)	9.5	None	17.1	None				
2	11	TR-04	6×10 (0.15~0.20)	6.3	6.3	14	14	39.7	22	26	M15×1-6H
		TR-05	10×16 (0.15~0.20)	7.9	7.9	15.5	15.5				
		TR-06	10×16 (0.15~0.20)	9.5	9.5	17.1	17.1				
		TR-07	10×16 (0.12~0.20)	11.1	11.1	18.7	18				
3	13	TR-08	16×24 (0.12~0.25)	12.7	None	20.3	None	45.2	25.1	29	M18×1-6H
		TR-04	6×10 (0.15~0.20)	6.3	6.3	14	14				
		TR-05	10×16 (0.15~0.20)	7.9	7.9	15.5	15.5				
		TR-06	10×16 (0.15~0.20)	9.5	9.5	17.1	17.1				
		TR-07	10×16 (0.12~0.20)	11.1	11.1	18.7	18.7				
4	15	TR-08	16×24 (0.12~0.25)	12.7	12.7	20.3	20.3	47.0	29	29	M22×1-6H
		TR-10	16×24 (0.10~0.30)	16	16	23.5	23				
		TR-05	10×16 (0.15~0.20)	7.9	None	15.5	None				
		TR-06	10×16 (0.15~0.20)	9.5	9.5	17.1	17.1				
		TR-07	10×16 (0.12~0.20)	11.1	11.1	18.7	18.7				
		TR-12	16×24 (0.10~0.30)	19	19	26.7	25.5				
5	17	TR-05	10×16 (0.15~0.20)	7.9	None	15.5	None	50.7	32.1	33	M25×1-6H
		TR-06	10×16 (0.15~0.20)	9.5	None	17.1	None				
		TR-07	10×16 (0.12~0.20)	11.1	11.1	18.7	18.7				
		TR-08	16×24 (0.12~0.25)	12.7	12.7	20.3	20.3				
		TR-10	16×24 (0.10~0.30)	16	16	23.5	23.5				
		TR-12	16×24 (0.10~0.30)	19	19	26.7	26.7				
6	19	TR-14	24×30 (0.10~0.30)	22.2	None	30	None	53.5	35.1	33	M28×1-6H
		TR-08	16×24 (0.12~0.25)	12.7	12.7	20.3	20.3				
		TR-10	16×24 (0.10~0.30)	16	16	23.5	23.5				
		TR-12	16×24 (0.10~0.30)	19	19	26.7	26.7				
		TR-14	24×30 (0.10~0.30)	22.2	22.2	30	30				
7	21	TR-16	24×30 (0.10~0.30)	25.4	25.4	33	32	55.7	38.1	39	M31×1-6H
		TR-08	16×24 (0.12~0.25)	12.7	12.7	20.3	20.3				
		TR-10	16×24 (0.10~0.30)	16	16	23.5	23.5				
		TR-12	16×24 (0.10~0.30)	19	19	26.7	26.7				
		TR-14	24×30 (0.10~0.30)	22.2	22.2	30	30				
		TR-16	24×30 (0.10~0.30)	25.4	25.4	33	33				
8	23	TR-18	30×40 (0.10~0.30)	28.5	None	36.2	None	58.2	41.1	39	M34×1-6H
		TR-10	16×24 (0.10~0.30)	16	16	23.5	23.5				
		TR-12	16×24 (0.10~0.30)	19	19	26.7	26.7				
		TR-14	24×30 (0.10~0.30)	22.2	22.2	30	30				
		TR-16	24×30 (0.10~0.30)	25.4	25.4	33	33				
		TR-18	30×40 (0.10~0.30)	28.5	28.5	36.2	36.2				
9	25	TR-20	30×40 (0.10~0.30)	31.8	None	39.4	None	63.7	44.1	44	M37×1-6H
		TR-10	16×24 (0.10~0.30)	16	None	23.5	None				
		TR-12	16×24 (0.10~0.30)	19	19	26.7	26.7				
		TR-14	24×30 (0.10~0.30)	22.2	22.2	30	30				
		TR-16	24×30 (0.10~0.30)	25.4	25.4	33	33				
		TR-18	30×40 (0.10~0.30)	28.5	28.5	36.2	36.2				
		TR-20	30×40 (0.10~0.30)	31.8	31.8	39.4	39.4				
TR-22	30×40 (0.10~0.30)	35	35	42.5	42						

GJB599 Series III (MIL-DTL-38999 Series III)

GJB599 Series III (MIL-DTL-38999 Series III)

[JY599 III -xxFJB00F] (Shielded Non-clamping Cable Accessory)

	Accessory Model	A	Thread B	D
	JY599III-11FJB00F	23	M15×1	6.5
	JY599III-15FJB00F	30	M22×1	12.5
	JY599III-17FJB00F	33	M25×1	19.5
	JY599III-21FJB00F	39	M31×1	25.5

[JY599 III xxFJC00] (Shielded Non-clamping Cable Accessory)

	Shell Number	Outlet Diameter of A	Thread B	D	Compatible Ti-Ni Ring Model
	11	7.9	M15×1	19.0	TR-05
	13	9.5	M18×1	22.8	TR-06
	15	12.7	M22×1	25.8	TR-08
	17	16.0	M25×1	29.2	TR-10
	19	19.0	M28×1	32.0	TR-12
	21	22.2	M31×1	35.1	TR-14
	23	25.4	M34×1	38.2	TR-16

[Model Example]

JY599III11FJC00F-7.9 is a model without a Ti-Ni ring;

When a Ti-Ni ring is needed, the model is JY599III11FJC00FA-05.

[JY599 III xxFJC00] (Shielded Non-clamping Cable Accessory)

		Shell Number	A max	Thread B	C - Outlet Diameter	D
		09	19	M12×1	6.3, 7.9, 9.5	20
		11	22	M15×1	6.3, 7.9, 9.5, 11.1, 12.7	23
		13	25.1	M18×1	6.3, 7.9, 9.5, 11.1, 12.7, 16	27
		15	29	M22×1	7.9, 9.5, 11.1, 12.7, 16, 19	30
		17	30	M25×1	7.9, 9.5, 11.1, 12.7, 16, 19, 22.2	33
		19	35.1	M28×1	12.7, 16, 19, 22.2, 25.4	36
		21	38.1	M31×1	12.7, 16, 19, 22.2, 25.4, 28.5	39
		23	41.1	M34×1	16, 19, 22.2, 25.4, 28.5, 31.8	42
		25	44.1	M37×1	19, 22.2, 25.4, 28.5, 31.8, 35	45

GJB599 Series III (MIL-DTL-38999 Series III)

[J1784/92-××J (Composite Material)] (Cable Clamping Non-Shielded Accessory)

[Square Plate Rubber Pad]

	Compatible Shell Number	Square Plate Rubber Pad Code	Conductive Square Plate Rubber Pad Code	A	B	C	G	D
	A	21E8-701-885-A1	21E8-701-886-A2	23.9	16.1	18.26	15.09	3.3
	B	21E8-701-887-A1	21E8-701-888-A2	26.3	19.2	20.62	18.26	3.3
	C	21E8-701-889-A1	21E8-701-890-A2	28.7	22.4	23.01	20.62	3.3
	D	21E8-701-891-A1	21E8-701-892-A2	31.1	25.6	24.61	23.01	3.3
	E	21E8-701-893-A1	21E8-701-894-A2	33.4	30.4	26.97	24.61	3.3
	F	21E8-701-895-A1	21E8-701-896-A2	36.6	32.0	29.36	26.97	3.3
	G	21E8-701-897-A1	21E8-701-898-A2	39.8	34.9	31.75	29.36	3.3
	H	21E8-701-899-A1	21E8-701-900-A2	43.0	38.3	34.93	31.75	4.0
	J	21E8-701-901-A1	21E8-701-902-A2	46.1	41.4	38.10	34.93	4.0

Note: Ordinary square plate rubber pads are provided with the product.
If conductive square plate rubber pads are needed, please specify when placing an order.

Special Contacts Selected for GJB599I, III, IV Series

Specification Type	American Standard Model	National Military Standard Model	Remarks
12# Pin	M39029/58-365	J1216/58-365	
12# Socket	M39029/56-353	J1216/56-353	
12# Pin	M39029/107-623	J1216/107-623	Service Life 1500 Times
12# Socket	M39029/106-617	J1216/106-617	Service Life 1500 Times
12# Shielded Pin	M39029/28-211	J1216/28-211	
	M39029/28-412	J1216/28-412	
12# Shielded Socket	M39029/75-416	J1216/75-416	
	M39029/75-422	J1216/75-422	
12# Coaxial Pin	M39029/102-558	J1216/102-558	
12# Coaxial Socket	M39029/103-559	J1216/103-559	
8# Twinaxial Pin	M39029/90-529	J1216/90-529	
8# Twinaxial Socket	M39029/91-530	J1216/91-530	
8# Analog Contact		J1784A/80-8	
12# Analog Contact		J1784A/80-12	
8# Seal Plug	MS27488-8 (White)	JY27488-8 (White)	Applicable to Series I, III, IV
10# Seal Plug	MS27488-10 (White)	JY27488-10 (White)	
12# Seal Plug	MS27488-12 (Yellow)	JY27488-12 (Yellow)	Applicable to Series I, II, III, IV
16# Seal Plug	MS27488-16 (Blue)	JY27488-16 (Blue)	
20# Seal Plug	MS27488-20 (Red)	JY27488-20 (Red)	
22D Seal Plug	MS27488-22 (Black)	JY27488-22 (Black)	

GJB5991V Series (MIL-DTL-38999IV Series) Electrical Connector

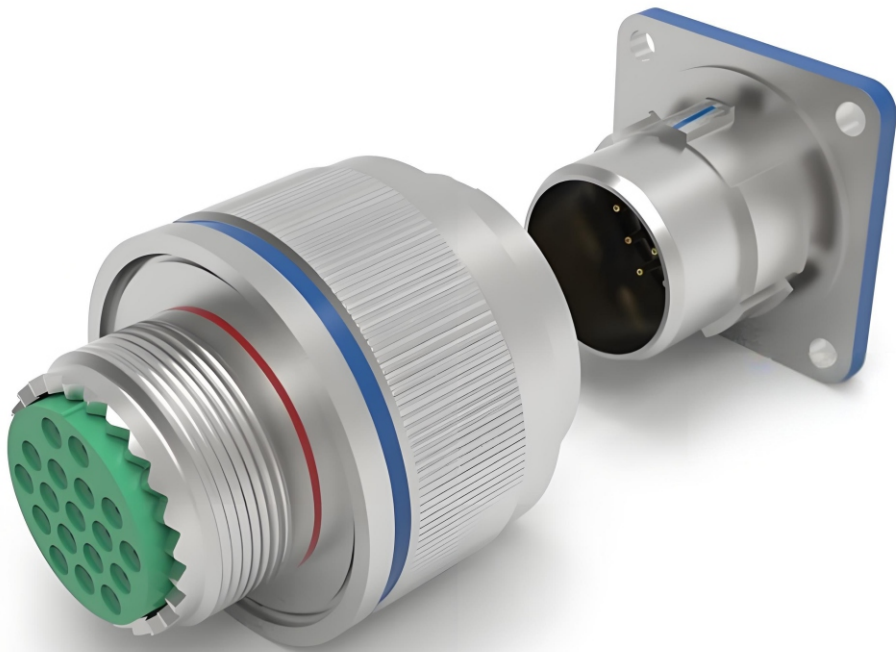

The pictures are for reference only

GJB599IV Series (MIL-DTL-38999IV Series) Electrical Connector

GJB599 IV Series (MIL-DTL-38999 IV Series) Electrical Connectors

Product Introduction

- Compliant with GJB599 (MIL-DTL-38999) Series IV
- High-density connector, with up to 128 cores
- Contact specifications include 22D, 20#, 16#, 12#, 10# power contacts, 16# shielded, 12# shielded, 12# coaxial, 8# dual coaxial, 8# quad coaxial contacts, and 12#, 16# optical contacts (contacts of the same specification are interchangeable)
- Bayonet coupling structure
- 100% anti-misinsertion
- With grounding pin, excellent EMI/RFI shielding performance
- Hole group arrangements include mixed high and low frequency, high frequency, low frequency, optical fiber, and optoelectronic hybrid forms
- Suitable for high-intensity vibration environments such as aerospace and military applications



Application

The product is used for electrical circuit signal connection.

Main Technical Performance

[Mechanical Performance]

Vibration: Sine vibration, frequency 10~2000Hz, acceleration 588m/s²; Random vibration,

frequency 100~1000Hz, power spectral density 1g²/Hz

Shock: 3ms half-sine wave, peak acceleration 300g

Mechanical Life: 500 cycles

[Environmental Performance]

Operating Temperature:

Type W: -65°C ~ +175°C

Other Types: -65°C ~ +200°C

Salt Spray Resistance: 500 hours (cadmium-plated), 48 hours (nickel-plated),

2000 hours (titanium alloy), 1000 hours (stainless steel)

Fungus Resistance: In accordance with GJB150.10, test duration 28 days

Fluid Resistance: Resistant to various fuels, coolants, and solvents

Contact Performance Indicators

[12# Coaxial Contact]

Contact Resistance:

Contact Specification	Inner Contact Body (mΩ)		Outer Contact Body (mΩ)	
	Normal Condition	After Test	Normal Condition	After Test
SFF-50-2-51	55	7.5	6.25	7.5
SFF-75-1.6-51	120	7.0	5.83	7.0

Operating Environment

The product is used in complex environments such as strong vibration, rain, wind and sand, and humidity.

[Electrical Performance]

Contact Resistance and Rated Current of Contacts:

Contact Specification	Working Diameter (mm)	Contact Resistance (mΩ)	Contact Resistance (mΩ)
22D	Φ0.76	≤14.6	≤14.6
20#	Φ1.00	≤7.5	≤7.5
16#	Φ1.60	≤3.7	≤3.7
12#	Φ2.40	≤1.83	≤1.83
10#	Φ3.15	≤1.0	≤1.0
8#	Φ3.60	≤0.57	≤0.57

Insulation Resistance:

Room temperature ≥ 5000MΩ; High temperature ≥ 1000MΩ; Humidity ≥ 100MΩ

Withstand Voltage: V

Operating Altitude*	M	N	I	II
Sea Level	1300	1000	1800	2300
21336m	800	600	1000	1000

Note: Different contact arrangements have different operating grades. For specific operating grades, please refer to the letter at the upper right corner of the contact arrangement diagram.

GJB5991V Series (MIL-DTL-38999IV Series) Electrical Connector

GJB5991V Series (MIL-DTL-38999IV Series) Electrical Connector

Low-Level Contact Resistance (Inner Contact Body Only, Maximum):

Compatible Cable	Initial Value (mΩ)	After Test (mΩ)
SFF-50-2-51	55	66
SFF-75-1.6-51	120	144

- Withstand Voltage: 1000V at sea level; 250V at 15240m (11.59KPa)
- Voltage Standing Wave Ratio: 500MHz~3GHz, not greater than $1.20 + 0.04f$
- Insertion Loss: $dB_{max} = 0.11\sqrt{f}$, not greater than 0.2dB at 3GHz
- Impedance: 50Ω
- Tensile Strength:

Compatible Cable	Axial Load (N)	
	Inner Contact Body	Outer Contact Body
SFF-50-2-51	44.48	44.48
SFF-75-1.6-51	15.57	15.57

Insertion Force and Separation Force of J1216/102 (M39029/102) Contacts:

Nominal Inspection Pin Diameter (mm)	Minimum Separation Force (N)		Maximum Insertion Force (N)	
	Initial	After Test	Initial	After Test
Φ0.52	—	—	3.34	3.90
Φ0.50	0.14	0.11	—	—

Insertion Force and Separation Force of J1216/103 (M39029/103) Contacts:

Nominal Inspection Pin Diameter (mm)	Minimum Separation Force (N)		Maximum Insertion Force (N)	
	Initial	After Test	Initial	After Test
Φ2.41	—	—	8.35	10.02
Φ2.36	0.83	0.70	—	—

Vibration: Tested according to GJB1217 Method 2005, Test Condition V, with a power spectral density of 5G²/Hz
[12# Coaxial Contact]

Contact Resistance

Inner Contact Body		Outer Contact Body	
Initial Value	After Test	Initial Value	After Test
120	144	5	6

Low-Level Contact Resistance (Inner Contact Body Only): Initial value 120mΩ, after test 144mΩ

Withstand Voltage: 1000V at sea level; 250V at 15240m (11.59KPa)

Tensile Strength: Inner contact body 15.57N, outer contact body 88.96N

Insertion Force and Separation Force of J1216/28 (M39029/28) Contacts:

Nominal Inspection Pin Diameter (mm)	Minimum Separation Force (N)		Maximum Insertion Force (N)	
	Initial	After Test	Initial	After Test
Φ0.521	—	—	3.34	3.90
Φ0.495	0.14	0.11	—	—

GJB5991V Series (MIL-DTL-38999IV Series) Electrical Connector

Insertion Force and Separation Force of J1216/75 (M39029/75) Contacts:

Nominal Inspection Pin Diameter (mm)	Minimum Separation Force (N)		Maximum Insertion Force (N)	
	Initial	After Test	Initial	After Test
φ2.413	—	—	8.35	10.02
φ2.362	0.83	0.70	—	—

[16# Coaxial Contact]

Contact Resistance:

Compatible Cable	Inner Contact Body(mΩ)		Outer Contact Body(mΩ)	
	Normal Condition	After Test	Normal Condition	After Test
SFF-50-2-51	55	66	6.25	7.5
SFF-75-1.6-51	120	144	5.83	7.0

Low-Level Contact Resistance (Inner Contact Body Only): Initial value 120mΩ, after test 144mΩ

Withstand Voltage: 800V at sea level; 250V at 15240m (11.59KPa)

[8# Twin Coaxial Contact]

	Center Contact Body (mΩ)	Intermediate Contact Body (mΩ)	External Contact Body (mΩ)
Normal Condition	55	55	6.25
After Test	66	66	7.5
After High-Temperature Life (175°C)	94	94	10.67

Low-Level Contact Resistance (Only Center and Intermediate Contact Bodies): Initial value 55mΩ; After test 66mΩ

Withstand Voltage:

Operating Altitude	Center to Intermediate Contact Body	Intermediate to External Contact Body
Sea Level	1000V	500V
15240m	250V	125V

Operating Frequency: 0~20MHz

Rated Voltage: 500V, 125V at 21336m (4.39KPa)

J1216/90(M39029/90) Contact Insertion Force and Separation Force:

Nominal Inspection Pin Diameter (mm)	Minimum Separation Force (N)		Maximum Insertion Force (N)	
	Initial	After Test	Initial	After Test
φ2.896	—	—	5	6.12
φ2.845	0.14	0.11	—	—

J1216/91(M39029/91) Contact Insertion Force and Separation Force:

Nominal Inspection Pin Diameter (mm)	Minimum Separation Force (N)		Maximum Insertion Force (N)	
	Initial	After Test	Initial	After Test
φ5.563	—	—	13.36	16.7
φ5.512	0.83	0.56	—	—
φ0.622	—	—	3.34	3.90
φ0.597	0.14	0.11	—	—

Tensile Strength:

Compatible Cable	Center Contact Body (N)	Intermediate Contact Body (N)	External Contact Body (N)
SEFF-78-1-51	35.59	35.59	111.21

GJB5991V Series (MIL-DTL-389991V Series) Electrical Connector

GJB5991V Series (MIL-DTL-389991V Series) Electrical Connector

Vibration: 10~2000Hz, Power Spectral Density 1.0G²/Hz•

Shock: Acceleration 2940 m/s²

[8# Twin Coaxial Contact]

Rated Voltage: 500V (Sea Level), 125V (21336m Altitude)

Contact Resistance:

Inner Contact Body (mΩ)		External Contact Body (mΩ)	
Initial Value	After Test	Initial Value	After Test
15	30	3	4

- Insulation Resistance: ≥5000MΩ at Room Temperature; ≥1000MΩ at High Temperature
- Characteristic Impedance: 100Ω (100MHz)
- Insertion Loss: ≤0.3dB (100MHz)
- Crosstalk: ≥40 dB (100MHz)
- Insertion Force and Separation Force: Maximum Insertion Force 11N; Minimum Separation Force 155N

[12#/16# Fiber Optic Contact]

- Insertion Loss: ≤0.3 dB (Single Core)
- Return Loss: ≥35dB (Only for Single-Mode Fiber)
- Interchangeability: Insertion Loss ≤0.6dB (Single Core); Return Loss ≥30dB (Only for Single-Mode Fiber)
- Vibration: Tested according to Method 2005 in GJB1217, Test Condition VI, Letter Code J, Insertion Loss ≤1.5dB after Test
- Shock: Tested according to Method 2004 in GJB1217, Test Condition D, Insertion Loss ≤1.5dB after Test
- Operating Temperature: -55°C ~ +125°C
- Mechanical Life: 500 Cycles

[Model Naming]

Series Main Name	J599/	40	W	B	35	P	N	V	RX	01																		
Type	40 – Wall-mounted square panel socket (rear accessories installable) 41 – Box-mounted square panel sealed socket (only Y, N types optional) 42 – Box-mounted square panel socket 43 – Nut-fastened sealed socket (only Y, N types optional) 44 – Nut-fastened socket (rear accessories installable) 45 – Soldered-mounted sealed socket (only N type optional) 46 – Shielded plug (rear accessories installable) 48 – Fusion-welded mounted hermetic socket (only Y, N types optional) 49 – Cable-connected socket (rear accessories installable)																											
Plating Type	See "Plating Categories and Their Performances" (only Y, N types apply to sealed sockets)																											
Housing Code	<table border="1" style="font-size: small;"> <tr> <th>Housing Code</th> <th>B</th> <th>C</th> <th>D</th> <th>E</th> <th>F</th> <th>G</th> <th>H</th> <th>J</th> </tr> <tr> <td>Corresponding Housing No</td> <td>11</td> <td>13</td> <td>15</td> <td>17</td> <td>19</td> <td>21</td> <td>23</td> <td>25</td> </tr> </table>										Housing Code	B	C	D	E	F	G	H	J	Corresponding Housing No	11	13	15	17	19	21	23	25
Housing Code	B	C	D	E	F	G	H	J																				
Corresponding Housing No	11	13	15	17	19	21	23	25																				
Contact Arrangement	See "Contact Arrangement Diagram" for details																											
Contact Category	P – Pin; S – Socket																											
Keying	N – Normal Keying; A, B, C, D, E – Modified Keying																											
Modification Code	V – Oil-resistant																											
Thermocouple Contacts & Quantity	RX – Single thermocouple contact, X indicates the number of thermocouple contact pairs (Note: When multiple thermocouple contact specifications are required, please contact our company.)																											
Housing Modification Model	01~99 (Add this code when product modification is needed, please contact our company)																											

GJB599IV Series (MIL-DTL-38999IV Series) Electrical Connector

[Model Marking Example]

J599/46KC35PNJ599 series 46 shielded plug, plating code K stainless steel passivation, housing C, contact arrangement 35, contacts are pins, keying N.

Notes:

- 1.The "8~10" part in the model marking is an additional descriptive marking, only indicated when needed.
- 2.Except for the main name code, the model naming of national military standard GJB599 and U.S. military standard MIL-DTL-38999 is completely the same. The main name code of GJB599 is "J599", and that of MIL-DTL-38999 is "D38999", and they are interchangeable.
- 3.When high oil resistance is required, the connector sealing material is fluorosilicone rubber, and "V" is added after the original model (e.g.: J599/46FC35PNV).

Plating Categories and Their Performances

Category Mark	Housing Material	Surface Treatment	Salt Spray Resistance	Shielding Performance	Temperature Class
F ¹⁾	Aluminum Alloy	Nickel Plating	48h	Up to 65dB at 10GHz	200°C
W	Aluminum Alloy	Cadmium Plating (Military Green)	500h	Up to 50dB at 10GHz	175°C
K	Stainless Steel	Passivation	1000h	Up to 45dB at 10GHz	200°C
S	Stainless Steel	Nickel Plating	1000h	Up to 65dB at 10GHz	200°C
TA	Titanium Alloy	—	2000h	Up to 65dB at 10GHz	200°C
R	Naval Brass	Nickel Plating	96h	Up to 65dB at 10GHz	200°C
Y ¹⁾	Stainless Steel	Passivation	500h	Up to 50dB at 10GHz	200°C
N ¹⁾	Stainless Steel	Nickel Plating	500h	Up to 65dB at 10GHz	200°C

1.Plating types Y and N are only used for sealed sockets.

2.In the JY599 IV series, the F plating is satin nickel, which is nickel-white in color.

When selecting accessories, please choose the FT plating (FT is electroless nickel plating). For example: J1784/38-19FT.

Crimp Contact

Contact Specification	Diameter mm	Pin Color Code	Socket Color Code	Crimp Barrel Inner Diameter mm	Crimp Barrel Outer Diameter mm	Compatible Wire Cross-Section mm ²	Compatible US Standard Cable AWG	Compatible Wire Insulation Outer Diameter mm	Removal Tool Code	Crimping Tool
22D	φ0.76	Orange-Blue-Black	Orange-Yellow-Gray	0.85	1.20	0.08 0.125 0.2 0.3	28 26 24 22	0.76~1.37	M81969/14-01	YJQ-02
20#	φ1.00	Orange-Blue-Orange	Orange-Green-Brown	1.17	1.78	0.2 0.3 0.5	24 22 20	1.02~2.11	M81969/14-10	YJQ-02
16#	φ1.60	Orange-Blue-Yellow	Orange-Green-Red	1.68	2.62	0.5 0.8 1.0 1.2	20 18 16	1.65~2.77	M81969/14-03	XCXY-01
12#	φ2.40	Orange-Blue-Green	Orange-Green-Orange	2.49	3.84	2.0 3.0	14 12	2.46~3.61	M81969/14-04	XCXY-01
10#	φ3.15	Green-Red-Gray	Green-Orange-Purple	3.40	4.65	3.0 4.8	12 10	3.42~4.12	M81969/14-05	XCXY-01
8#	φ3.6	—	—	4.55	6.4	8.37	8	6.4~6.9	M81969/14-12	YTQ

Note: For the required crimping tools and their usage instructions, please refer to "Usage Instructions for Crimping Tools Matching GJB599 Series Products".

GJB5991V Series (MIL-DTL-38999IV Series) Electrical Connector

GJB5991V Series (MIL-DTL-38999IV Series) Electrical Connector

Soldered Contact

Specification of Soldered Contact	Inner Diameter of Solder Cup	Maximum Compatible Wire Gauge (AWG)
22D	$\varphi 0.9$	22
20#	$\varphi 1.1$	20
16#	$\varphi 1.9$	16
12#	$\varphi 2.9$	12
10#	$\varphi 3.6$	10
8#	$\varphi 4.8$	8

Key Position

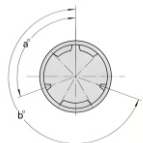
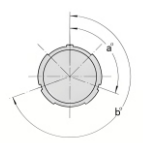
<div style="display: flex; justify-content: space-around;"> <div style="text-align: center;"> <p>Key Position Angle of Connecting Nut</p>  </div> <div style="text-align: center;"> <p>Key Position Angle of Socket Housing</p>  </div> </div>	Key Position Angle	a	b
	N	110°	250°
	A	100°	260°
	B	90°	270°
	C	80°	280°
	D	70°	290°
	K	120°	255°

GJB599IV Series (MIL-DTL-38999IV Series) Electrical Connector

Contact Arrangement (View of Mating Face of Pin - Loaded Insulator)

11 (B)	35 M 13-22D	98 I 6-20#	05 I 5-20#	04 I 4-20#	01 I 1-12#	99 I 7-20#	02 I 2-16#	
	35 M 22-22D	98 I 10-20#	08 I 8-20#	04 I 4-16#	03 I 3-16#	12 N 1-12# 11-22D		
15 (D)	35 M 37-22D	19 I 19-20#	18 I 18-20#	05 II 5-16#	97 I 8-20# 4-16#	15 I 14-20# 1-16#		
	35 M 55-22D	26 I 26-20#	06 I 6-12#	08 II 8-16#	99 I 2-16# 21-20#	02 M 1-8# Twin Coaxial 38-22D		
19 (F)	35 M 66-22D	32 I 32-20#	11 II 11-16#	28 I 26-20# 2-16#	30 I 29-20# 1-16#			
	45 M 67-22D	18 M 4-8# Twin Coaxial 14-22D	93 I 24-22D 6-20# 2-10#					
21 (G)	35 M 79-22D	41 I 41-20#	16 II 16-16#	39 I 37-20# 2-16#	11 M 11-12#			
	27 I 27-20#	25 I 25-20#	24 I 24-20#					

GJB599IV Series (MIL-DTL-38999IV Series) Electrical Connector

GJB599IV Series (MIL-DTL-38999IV Series) Electrical Connector

23 (H)	35 100-22D	55 55-20#	53 53-20#	36 36-20#
	34 34-20#	32 32-20#	21 21-16#	97 16-16#
	99 11-16#			
25 (J)	35 128-22D	61 61-20#	46 40-20# 4-16# 2-8#	29 29-16#
	24 12-10# 12-12#	43 23-20# 20-16#	19 19-12#	04 48-20# 8-16#
	11 2-20# 9-10#	20 10-20# 13-16# 1-12# Coaxial 3-12# Shielded Coaxial 3-8# Twin Coaxial	93 110-22D 8-16#	07 97-22D 2-8# Twin Coaxial
	69 10-16# 15-20# 44-22D			

Power Contact Component Specifications

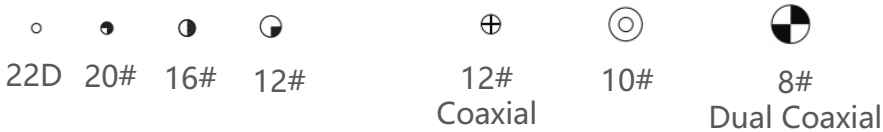

GJB599IV Series (MIL-DTL-38999IV Series) Electrical Connector

Overall Dimensions

[J599/46 Shielded Plug]

	Shell Number	Shell Number Code	Amax	Thread B (-6g)
	11	B	26.6	M15×1
	13	C	30.8	M18×1
	15	D	34.0	M22×1
	17	E	37.4	M25×1
	19	F	40.0	M28×1
	21	G	43.2	M31×1
	23	H	46.5	M34×1
	25	J	49.7	M37×1

[J599/40 Wall-Mounted Square Flange Mounted Socket]

Shell Number	Shell Number Code	B max	C max	Thread D (-6g)	E	F	H	d (Front Mounting)	d (Rear Mounting)
11	B	2.6	20.1	M15×1	20.62	26.2	3.2	15.3	20.5
13	C	2.6	23.3	M18×1	23.02	28.6	3.2	19.2	23.7
15	D	2.6	26.5	M22×1	24.62	31.0	3.2	23.3	26.9
17	E	2.6	29.66	M25×1	26.98	33.3	3.2	25.9	31.0
19	F	2.6	32.8	M28×1	29.36	36.5	3.2	29.0	33.0
21	G	3.2	36.0	M31×1	31.76	39.7	3.2	32.2	36.2
23	H	3.2	39.2	M34×1	34.92	42.9	3.7	35.0	39.4
25	J	3.2	42.4	M37×1	38.10	46.0	3.7	37.8	42.6

[J599/41 Box-Type Square Flange Mounted Sealed Socket]

Shell Number	Shell Number Code	B max	C max	D	E	F	H	d (Front Mounting)	d (Rear Mounting)
11	B	2.6	20.1	15.38	20.62	26.2	3.2	16.0	20.5
13	C	2.6	23.3	18.55	23.02	28.6	3.2	19.0	23.7
15	D	2.6	26.5	22.51	24.62	31.0	3.2	23.0	26.9
17	E	2.6	29.66	25.31	26.98	33.3	3.2	26.0	31.0
19	F	2.6	32.8	29.43	29.36	36.5	3.2	29.8	33.0
21	G	3.2	36.0	31.06	31.76	39.7	3.2	31.8	36.2
23	H	3.2	39.2	34.33	34.92	42.9	3.7	35.0	39.4
25	J	3.2	42.4	37.19	38.10	46.0	3.7	38.0	42.6

GJB599IV Series (MIL-DTL-38999IV Series) Electrical Connector

[J599/42 Box-Type Square Flange Mounted Socket]

Shell Number	Shell Number Code	B max	L	L1	C max	D max	E	F	H	d (Front Mounting)	d (Rear Mounting)
11	B	2.6	31.2	2.1	20.1	14.6	20.62	26.2	3.2	15.3	20.5
13	C	2.6	31.2	2.1	23.3	17.5	23.02	28.6	3.2	19.2	23.7
15	D	2.6	31.2	2.1	26.5	20.7	24.62	31.0	3.2	23.3	26.9
17	E	2.6	31.2	2.1	29.66	23.9	26.98	33.3	3.2	25.9	31.0
19	F	2.6	31.2	2.1	32.8	26.6	29.36	36.5	3.2	29.0	33.0
21	G	3.2	31.8	1.5	36.0	29.6	31.76	39.7	3.2	32.2	36.2
23	H	3.2	31.8	1.5	39.2	32.9	34.92	42.9	3.7	35.0	39.4
25	J	3.2	31.8	1.5	42.4	36.1	38.10	46.0	3.7	37.8	42.6

[J599/43 Nut Fastened Sealed Socket]

Shell Number	Shell Number Code	Thread D (-6g)	E max	F max	G max	d	p
11	B	M20×1	31.6	19.17	34.8	20.5	19.5
13	C	M25×1	34.8	23.92	38.1	25.5	24.3
15	D	M28×1	38.0	27.07	41.2	28.5	27.3
17	E	M32×1	41.1	30.25	44.5	32.5	30.7
19	F	M35×1	45.9	33.44	49.2	35.5	33.8
21	G	M38×1	49.1	36.62	52.3	38.5	37.0
23	H	M41×1	52.2	39.75	55.5	41.5	40.1
25	J	M44×1	55.4	42.98	58.6	44.5	43.1

GJB599IV Series (MIL-DTL-38999IV Series) Electrical Connector

[J599/44 Nut Fastened Socket]

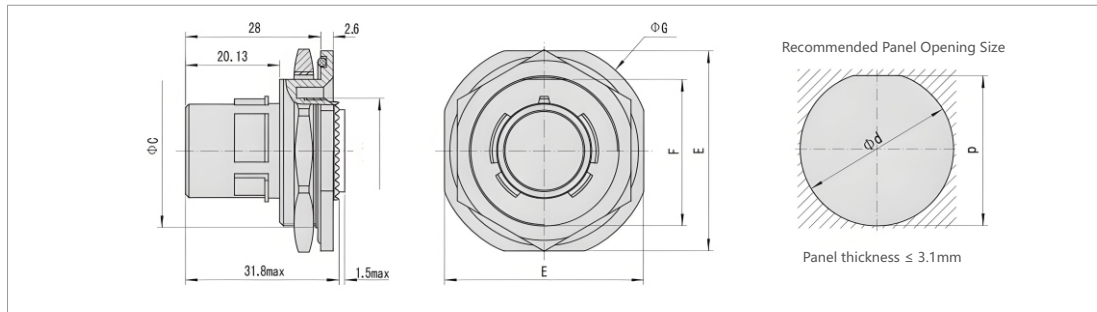

Shell Number	Shell Number Code	C max	Thread D (-6g)	E max	F max	G max	d	p
11	B	25.4	M15×1	34.9	23.93	38.1	25.6	24.3
13	C	28.58	M18×1	38.1	27.08	41.2	28.8	27.3
15	D	31.75	M22×1	41.3	30.26	44.5	32.2	30.7
17	E	34.92	M25×1	45.2	33.56	49.2	35.2	33.8
19	F	38.10	M28×1	48.0	36.61	51.2	38.4	37.0
21	G	41.28	M31×1	51.2	39.78	54.3	41.6	40.1
23	H	44.45	M34×1	54.3	42.96	57.5	44.7	43.1
25	J	47.63	M37×1	57.5	46.13	60.7	48.0	46.3

[J599/45 Soldered Mounting Sealed Socket]

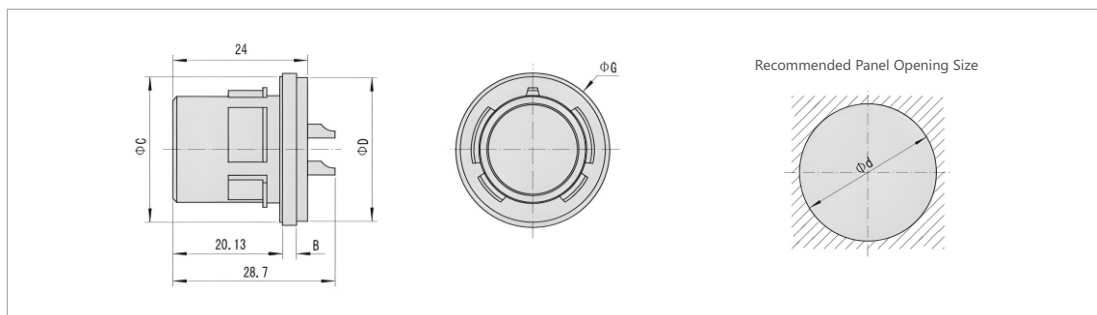

Shell Number	Shell Number Code	B max	C max	D max	G max	d
11	B	2.6	20.1	19.9	21.9	20.4
13	C	2.6	23.3	23.1	25.1	23.6
15	D	2.6	26.5	26.3	28.2	26.8
17	E	2.6	29.66	29.4	31.4	29.9
19	F	2.6	32.8	31.8	33.8	32.3
21	G	3.2	36.0	35.0	37.0	35.5
23	H	3.2	39.2	38.2	40.2	38.7
25	J	3.2	42.4	41.4	43.3	41.9

GJB599IV Series (MIL-DTL-38999IV Series) Electrical Connector

[J599/48 Fusion Welded Mounting Sealed Socket]

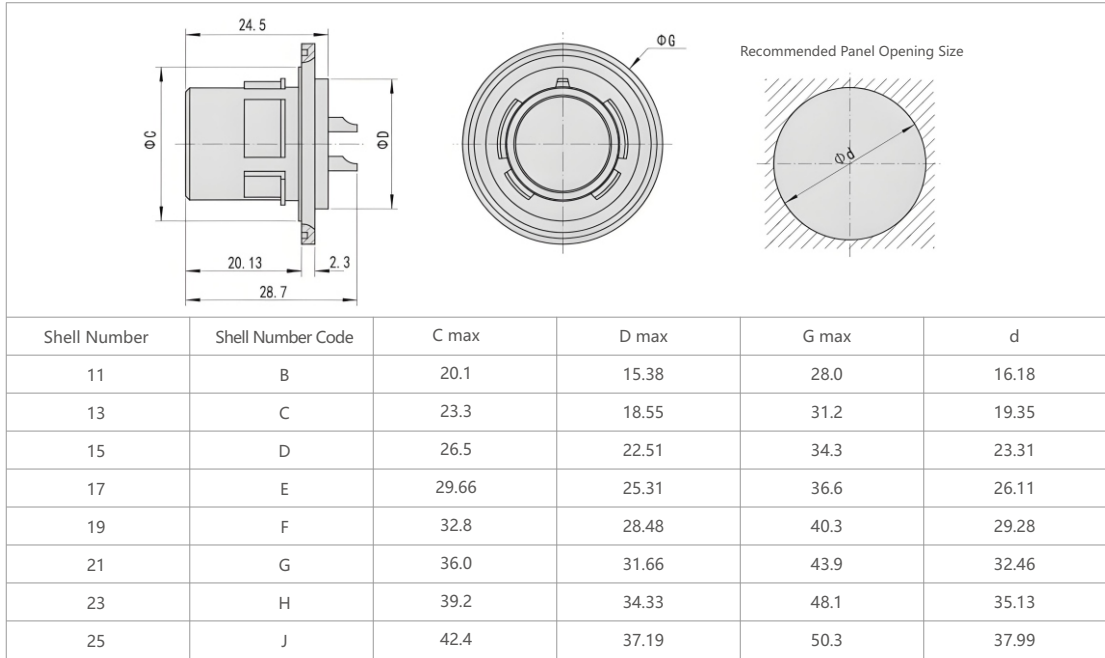

[J599/49 Cable Connection Socket]

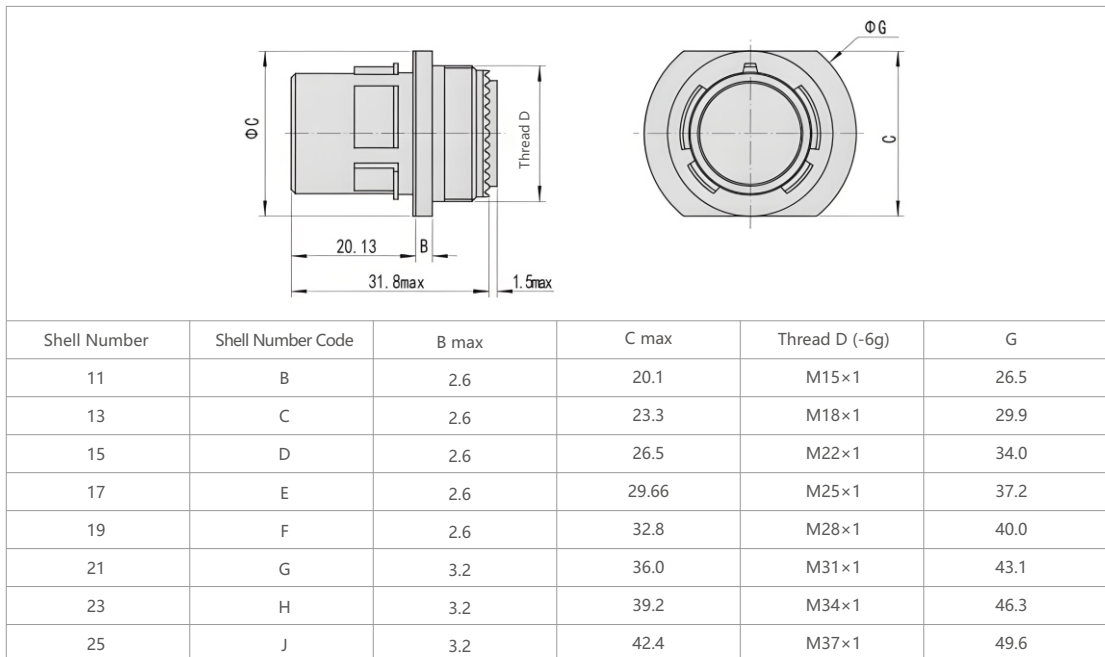

GJB599IV Series (MIL-DTL-38999IV Series) Electrical Connector

Precautions for Use

When using the product, first insert the plug straight into place (the end face of the connecting nut fits with the socket), then rotate the connecting nut 90° clockwise. A clear click sound and obvious hand feel can be heard, and the red band of the plug is completely covered at the same time. At this point, the connection is in place. After that, rotate the connecting nut 90° counterclockwise. There is also a click sound and hand feel, and the red band will be exposed. At this point, the connector is smoothly separated.

Tail Accessories

Plug and Socket Sealing Caps

[Model Naming]

Series Main Name	J599/	51-	F	15	N
Type	51-Plug Sealing Cap (Corresponding to US Military Standard Part Number D38999/51) 52-Socket Sealing Cap (Corresponding to US Military Standard Part Number D38999/52)				
Surface Coating	W-Aluminum Shell Cadmium-Plated Olive Drab F-Aluminum Shell Electroless Nickel Plating				
Shell Number	11-13-15-17-19-21-23-25				
Chain Type	R-Stainless Steel Twisted Chain with Connecting Piece (Suitable for Flange Socket) N-Stainless Steel Twisted Chain with Ring (Suitable for Nut-Fixed Socket) C-Nylon Rope with Connecting Piece (Suitable for Flange Socket) S-Nylon Rope with Ring (Suitable for Nut-Fixed Socket)				

Note: Sealing caps need to be ordered separately and are not supplied with the connector.

[Plug Sealing Cap]

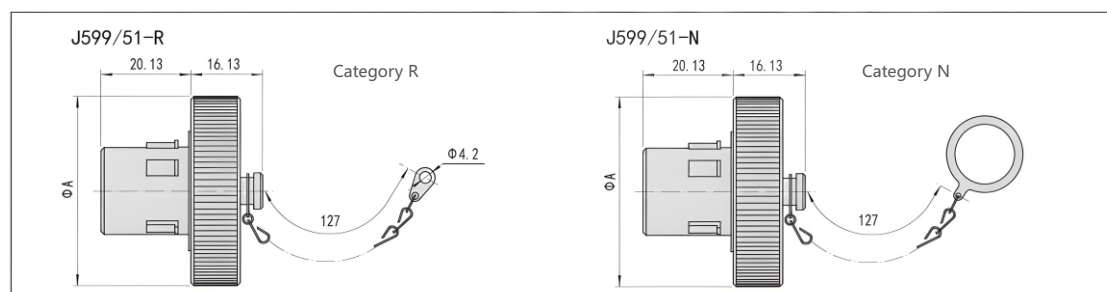

Socket Sealing Cover

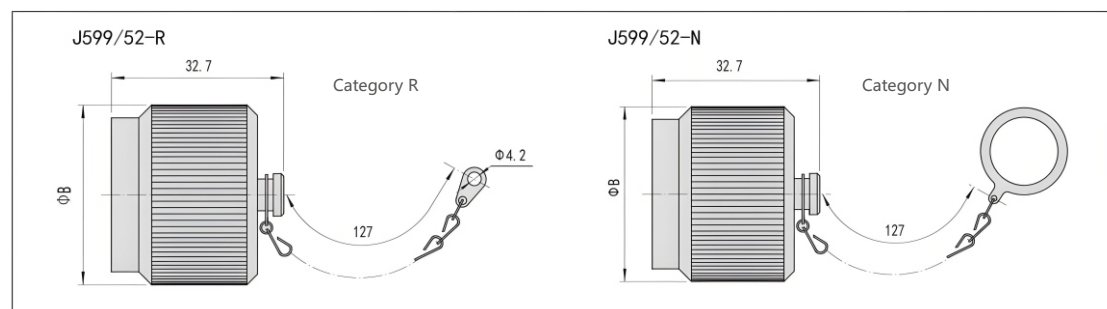

Shell Number	11	13	15	17	19	21	23	25
Shell Number Code	B	C	D	E	F	G	H	J
A	35.05	39.88	42.16	45.47	48.77	52.32	57.15	56.85
B	23.42	26.59	30.96	34.14	37.31	40.11	43.28	46.46

GJB599 Series I (MIL-DTL-38999 Series I) Electrical Connector

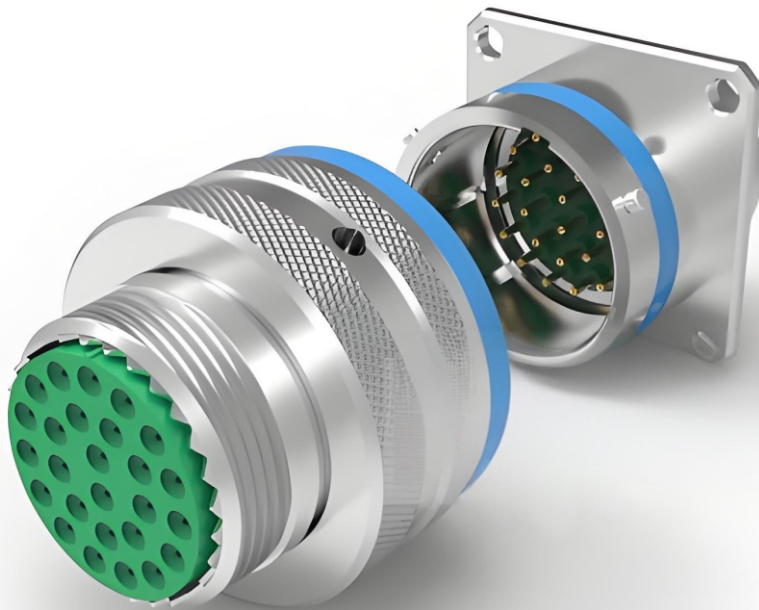

The pictures are for reference only

GJB599 Series I (MIL-DTL-38999 Series I) Electrical Connector

Product Introduction

- Complies with GJB599A (MIL-DTL-38999K) Series I
- Bayonet-style quick connect
- Small size, lightweight, high contact density
- EMI / RFI shielding
- Contacts are crimp-removable with anti-drift design
- Receptacles are available in box, wall, front-mount, rear-mount, and nut-clamp mounting styles
- Withstands high-strength vibration
- Complies with GJB1784 standard rear accessories, suitable for dedicated rear accessories (Ti-Ni shape memory alloy) for shielded cable clamps
- 9 shell sizes, 74 standard contact arrangements and multiple derived contact arrangements
- The mating interface and tail have a sealed structure, with excellent environmental resistance (three defenses performance)
- Five-position keying mechanism with five anti-misinsertion positions

• The product is used for electrical circuit signal connection.

Main Technical Performance

[Mechanical Performance]

- Shell: Aluminum alloy, stainless steel, titanium alloy
- Plating Layer:
 - Type B: Cadmium-nickel plated olive green
 - Type E: Stainless steel passivation
 - Type FT: Inconel plated matte surface; Type TA: Titanium alloy
 - Type F: Chemical nickel plating
- Insulator: Thermosetting plastic or thermoplastic
- Wire Seal and Grommet: Silicone rubber material

[Electrical Performance]

Contact Resistance of Contacts and Rated Current

Contact Insert Specification	Operating Diameter (mm)	Contact Resistance (mΩ)	Rated Current (A)
22D	Φ0.76	≤12	5
20#	Φ1.00	≤5	7.5
16#	Φ1.60	≤2.5	13
12#	Φ2.40	≤1.5	23
10#	Φ3.15	≤1.0	40

Electromagnetic Interference Shielding:

At 100MHz ~ 1GHz, the minimum attenuation is 85dB

At 1GHz ~ 10GHz, the minimum attenuation is 50dB

[Environmental Performance]

- Operating Temperature:
 - Type B: -65°C ~ +175°C
 - Types E, F, FT, TA: -65°C ~ +200°C
- Salt Spray Resistance:
 - Type B: 500h; Type E, TA: 1000h
 - Type F: 48h; Type FT: 96h



- Widely used in aerospace, aviation, weapons and other military systems and other electronic equipment systems
- Implements enterprise standards
 - Standard crimp products: 21E0.204.102.1JT
 - Ordinary solder and printed board products: 21E0.204.102JT

Operating Environment

The product is used in complex environments such as strong vibration, sand and dust, and humidity.

- Contacts: Copper alloy gold-plated, crimp type, solder type, printed board type
- Mechanical life: 500 cycles
- Vibration:
 - Sine vibration: Frequency 10~2000Hz, Acceleration 294m/s²
 - Random vibration: Frequency 100~1000Hz, Power spectral density 1g²/Hz
- Shock: 3ms half-sine wave, Acceleration peak 300g

Withstand Voltage: V

Operating Class*	M	N	I	II
Sea Level	1300	1000	1800	2300
21000m	800	600	1000	1000

Note: Different contact arrangements have different operating classes. For specific operating classes, please refer to the letter in the upper right corner of the contact arrangement diagram.

- Insulation Resistance:
 - Normal conditions ≥ 5000MΩ; Humid conditions ≥ 100MΩ
- Shell-to-Shell Continuity:
 - Type B ≤ 2.5mΩ; Types F, FT ≤ 1.0mΩ
 - Types E, TA ≤ 50mΩ
- Relative Humidity: Up to 98% at 40°C
- Operating Altitude: ≤ 30480m
- The electrical connector also has excellent performance in moisture resistance, salt spray resistance, mildew resistance, and sand and dust resistance.

GJB599 Series I (MIL-DTL-38999 Series I) Electrical Connector

Model Naming

Series Main Title	JY	27467	T	17	F	35	P	N	-H	-S
Type	27467-Plug (Shell type only T type) 27466-Wall-mounted square panel front-mounted receptacle (Shell type only T type) 27656-Wall-mounted square panel rear-mounted receptacle (Shell type only T type) 27496-Box-mounted square panel front-mounted receptacle (Shell type only E type) 27505-Box-mounted square panel rear-mounted receptacle (Shell type only E type) 27468-Nut-mounted receptacle (Shell type only T type)									
Shell Type	T-Tail with threads, can install rear accessories E-Tail without threads, cannot install rear accessories									
Shell Number	09-11-13-15-17-19-21-23-25									
Shell Plating	B-Cadmium-nickel plated olive green E-Stainless steel passivation F-Chemical nickel plating FT-Aluminum alloy plated matte surface TA-Titanium alloy									
Contact Arrangement	Refer to "Contact Arrangement" diagram (If the contact arrangement is letter-printed, add "e" after the contact code to indicate number-printed)									
Contact Type	Crimp and solder type		PL-Long printed board pin SL-Long printed board socket PC-Short printed board pin SC-Short printed board socket							
Key Position	N-Normal key A, B, C, D-Variable key When crimp-type contacts are used, N may not be identified; when other types of contacts are used, N must be identified. (Shell No. 09 only has three key positions: N, A, D)									
Solder Contact Type	(Only applicable to solder connectors) H-Solder contact									
With Insurance Hole Marking	-S (Applicable to plugs and receptacles, square panel receptacles with M3×12 aviation standard screws) -S10 (With M3×10 aviation standard screws, applicable to square panel receptacles) -S14 (With M3×14 aviation standard screws, applicable to square panel receptacles) -S16 (With M3×16 aviation standard screws, applicable to square panel receptacles) -SC (With M3×12 countersunk aviation standard screws, applicable to square panel receptacles with panel in countersunk installation form) -S10C (With M3×10 countersunk aviation standard screws, applicable to square panel receptacles with panel in countersunk installation form)									

Note:
 In the model naming of China Military Standard GJB599A and U.S. Military Standard MIL-DTL-38999K, except for the different main title codes, the rest are completely the same. The main title code of GJB599A is "JY", and that of MIL-DTL-38999K is "MS", and they are interchangeable and compatible.
 The sealing caps, tail accessories, square panel rubber gaskets, etc. adapted to this series of products will be described later.
 When there is a requirement for resistance to high-temperature oil, the material of the connector sealing parts is fluorosilicone rubber, and "C1" is added at the end of the original model (e.g.: JY27467T17F35PNC1).
 When the product needs to be matched with a conductive square panel rubber gasket, add "C2" or "(C2)" at the end of the product model; when the product needs to be matched with a conductive O-ring, add "C5" or "(C5)" at the end of the product model, e.g.: JY27466T17F35PNC2, JY27468T17F35PNC5. Among them, (C2) and (C5) are not printed on the product model marking, while C2 and C5 without parentheses are printed on the product model.
 When the plug has a fuse, the fuse uses Φ0.5 soft stainless steel wire.

[Model Marking Examples]

JY27467T25E35SN-HJY series plug, with threads at the shell tail for installing accessories, shell No. 25, shell plating layer of stainless steel passivation, 35 contact arrangement, contact type is socket, N key position. Welded contact parts are only suitable for welded connectors.
 JY27466T25F35PN-SJY series wall-mounted square panel front-mounted receptacle, with threads at the tail for installing accessories, shell No. 25, shell plating layer of aluminum alloy chemical nickel plating, 35 contact arrangement, contact type is pin, N key position, crimp type, equipped with M3×12 aviation standard screws, flat washers and spring washers.

GJB599 Series I (MIL-DTL-38999 Series I) Electrical Connector

Crimp Contact

Contact Specification	Diameter mm	Pin Color Code	Socket Color Code	Crimp Barrel Inner Diameter mm	Crimp Barrel Outer Diameter mm	Compatible Wire Cross-Section mm ²	Compatible US Standard Cable AWG	Compatible Wire Insulation Outer Diameter mm	Removal Tool Code	Crimping Tool
22D	φ0.76	Orange-Blue-Black	Orange-Yellow-Gray	0.85	1.20	0.08 0.125 0.2 0.3	28 26 24 22	0.76~1.37	M81969/14-01	YJQ-02
20#	φ1.00	Orange-Blue-Orange	Orange-Green-Brown	1.17	1.78	0.2 0.3 0.5	24 22 20	1.02~2.11	M81969/14-10	YJQ-02
16#	φ1.60	Orange-Blue-Yellow	Orange-Green-Red	1.68	2.62	0.5 0.8 1.0 1.2	20 18 16	1.65~2.77	M81969/14-03	YJQ-02 XCXY-01
12#	φ2.40	Orange-Blue-Green	Orange-Green-Orange	2.49	3.84	2.0 3.0	14 12	2.46~3.61	M81969/14-04	XCXY-01
10#	φ3.15	Green-Red-Gray	Green-Orange-Purple	3.40	4.65	4.8	12 10	3.42~4.12	M81969/14-05	XCXY-01 YTQ
8#	φ3.6	—	—	4.55	6.4	8.37	8	6.4~6.9	M81969/14-12	YTQ

For the required crimping tools and their usage instructions, refer to "Usage Instructions for Crimping Tools Matched with GJB599 Series Products". Applicable to GJB599 Series I, III, and IV.

Solder Contact

Specification of Soldered Contact	Inner Diameter of Solder Cup	Maximum Compatible Wire Gauge (AWG)
22D	φ0.9	22
20#	φ1.1	20
16#	φ1.9	16
12#	φ2.9	12
10#	φ3.6	10
8#	φ4.8	8

GJB599 Series I (MIL-DTL-38999 Series I) Electrical Connector

GJB599 Series I (MIL-DTL-38999 Series I) Electrical Connector

Contact Arrangement (View of Pin Insulator Mating Face)

Shell Number 09 (A)	 35 M 6-22D	 98 I 3-20#	 02 I 2-20#	 03 I 3-20#	 10 I 1-12#	 11 I 1-16#	
Shell Number 11 (B)	 35 M 13-22D	 98 I 6-20#	 05 I 5-20#	 04 I 4-20#	 01 I 1-12#	 99 I 7-20#	 02 I 2-16#
	 15 N 4-22D 1-12#	 43 M 3-16#					
Shell Number 13 (C)	 35 M 22-22D	 98 I 10-20#	 08 I 8-20#	 04 I 4-16#	 12 N 1-12# 11-22D	 50 M 4-20# 1-10#	 60 I 4-16# 2-20#
	 03 I 3-16#	 02 I 2-12#	 05 I 1-16# 2-12#	 24 I 1-12#	 45 I 5-16#	 13 N 3-16# 10-22D	 26 M 2-12# 6-22D
	 99 I 3-16# 4-20#						
Shell Number 15 (D)	 35 M 37-22D	 19 I 19-20#	 18 I 18-20#	 05 I 5-16#	 97 I 8-20# 4-16#	 15 I 14-20# 1-16#	
	 02 I 2-12#	 14 N 8-22D 6-16#	 31 M 30-22D 1-12#	 38 I 4-12#	 48 I 8-16#	 12 M 2-12# 8-22D	
	 23 M 3-16# 2-20# 18-22D						

Power Contact Component Specifications

22D	20#	16#	12#	12#	12#	10#	8#	8#
Shielded Coaxial						Dual Coaxial		

GJB599 Series I (MIL-DTL-38999 Series I) Electrical Connector

17 (E)						
19 (F)						

Power Contact Component Specifications



GJB599 Series I (MIL-DTL-38999 Series I) Electrical Connector

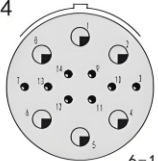
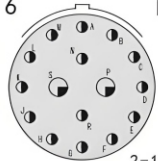
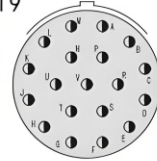
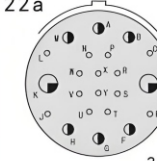
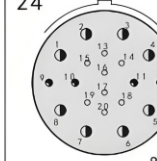
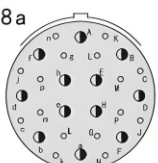
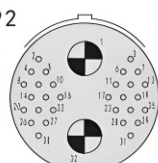
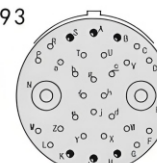
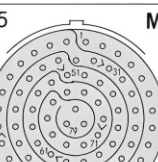
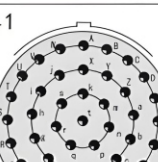
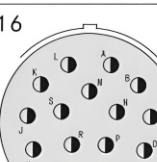
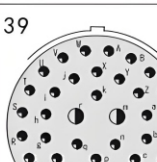
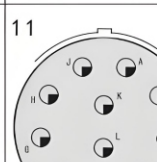
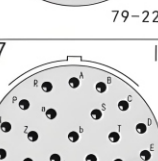
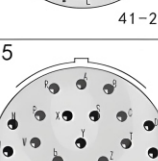
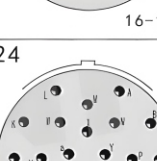
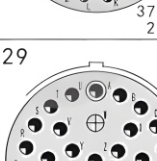
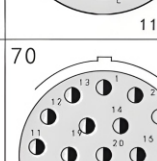
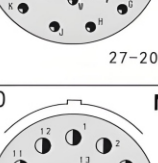
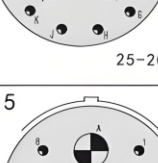
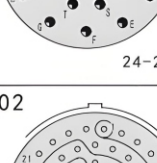
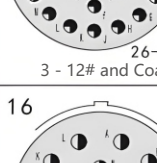
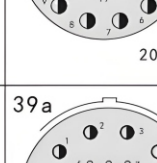
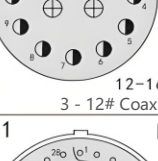
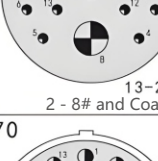

GJB599 Series I (MIL-DTL-38999 Series I) Electrical Connector

19 (F)	 <p>14 I</p> <p>6-12# 8-20#</p>	 <p>16 M</p> <p>2-12# 14-16#</p>	 <p>19 M</p> <p>19-16#</p>	 <p>22a M</p> <p>2-12# 6-16#, 14-22D</p>	 <p>24 I</p> <p>8-16# 4-20#, 8-22D</p>
	 <p>28a I</p> <p>12-16# 16-22D</p>	 <p>92 M</p> <p>30-22D 2-8# and Coaxial</p>	 <p>93 I</p> <p>2-10# 6-20#, 24-22D</p>		
21 (G)	 <p>35 M</p> <p>79-22D</p>	 <p>41 I</p> <p>41-20#</p>	 <p>16 I</p> <p>16-16#</p>	 <p>39 I</p> <p>37-20# 2-16#</p>	 <p>11 II</p> <p>11-12#</p>
	 <p>27 I</p> <p>27-20#</p>	 <p>25 I</p> <p>25-20#</p>	 <p>24 I</p> <p>24-20#</p>	 <p>29 M</p> <p>26-20# 3-12# and Coaxial</p>	 <p>70 M</p> <p>20-16#</p>
	 <p>80 M</p> <p>12-16# 3-12# Coaxial</p>	 <p>15 I</p> <p>13-20# 2-8# and Coaxial</p>	 <p>02 M</p> <p>65-22D</p>	 <p>16 II</p> <p>16-16#</p>	 <p>39a M</p> <p>8-16# 31-22D</p>
	 <p>61 N</p> <p>6-16# 55-22D</p>	 <p>70 M</p> <p>20-16#</p>			

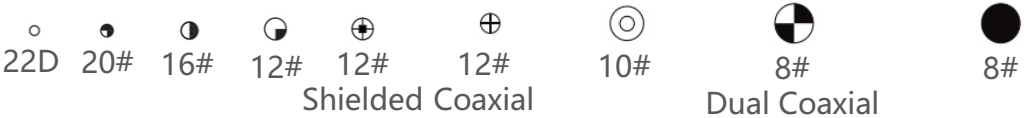
Power Contact Component Specifications

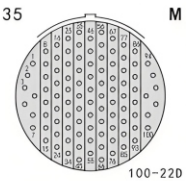
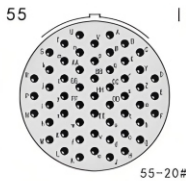
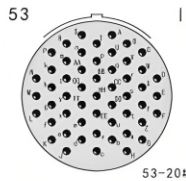
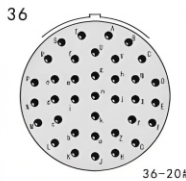
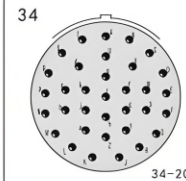
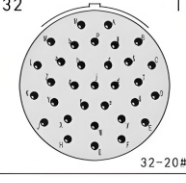
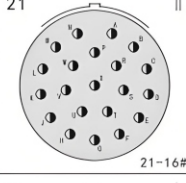
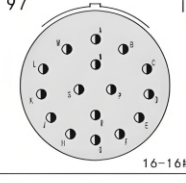
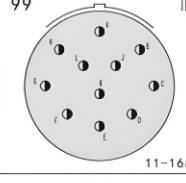
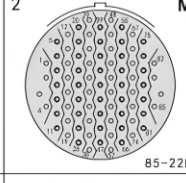
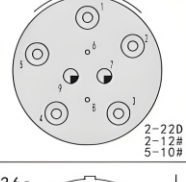
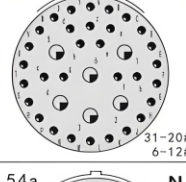
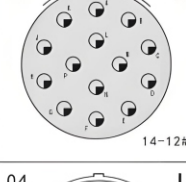
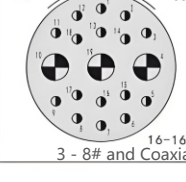
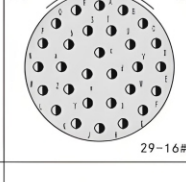
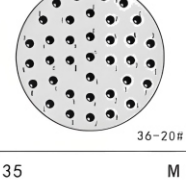
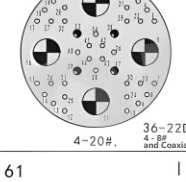
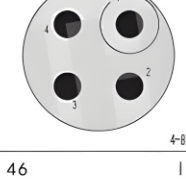
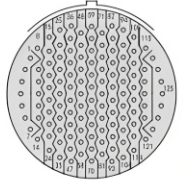

GJB599 Series I (MIL-DTL-38999 Series I) Electrical Connector

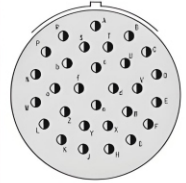
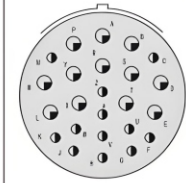
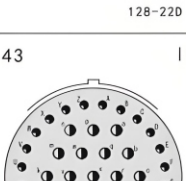
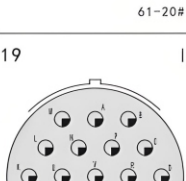
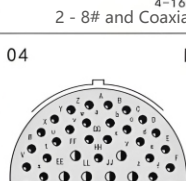
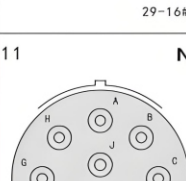
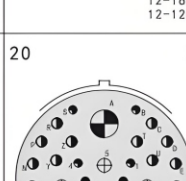
23 (H)	 <p>35 M 100-22D</p>	 <p>55 I 55-20#</p>	 <p>53 I 53-20#</p>	 <p>36 I 36-20#</p>	 <p>34 I 34-20#</p>
	 <p>32 I 32-20#</p>	 <p>21 II 21-16#</p>	 <p>97 I 16-16#</p>	 <p>99 II 11-16#</p>	 <p>2 M 85-22D</p>
	 <p>09a M 2-22D 2-12# 5-10#</p>	 <p>37 I 31-20# 6-12#</p>	 <p>14 M 14-12#</p>	 <p>15 N 16-16# 3-8# and Coaxial</p>	 <p>29 M 29-16#</p>
	 <p>36a I 36-20#</p>	 <p>54a N 4-20# 36-22D 4-8# and Coaxial</p>	 <p>04 I 4-8#</p>		
25 (J)	 <p>35 M 128-22D</p>	 <p>61 I 61-20#</p>	 <p>46 I 4-20# 4-16# 2-8# and Coaxial</p>	 <p>29 I 29-16#</p>	 <p>24 I 12-16# 12-12#</p>
	 <p>43 I 23-20# 20-16#</p>	 <p>19 I 19-12#</p>	 <p>04 I 48-20# 8-16#</p>	 <p>11 N 2-20# 9-10#</p>	 <p>20 N 10-20# 13-16# 1-12# Coaxial, 3-12# Triaxial 3-8# Double Coaxial</p>

Power Contact Component Specifications

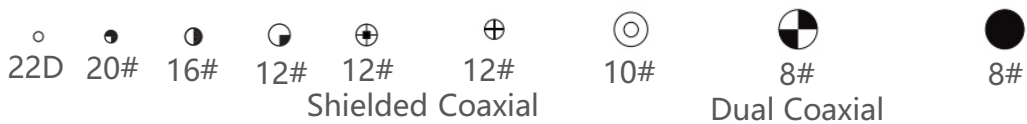

GJB599 Series I (MIL-DTL-38999 Series I) Electrical Connector

GJB599 Series I (MIL-DTL-38999 Series I) Electrical Connector

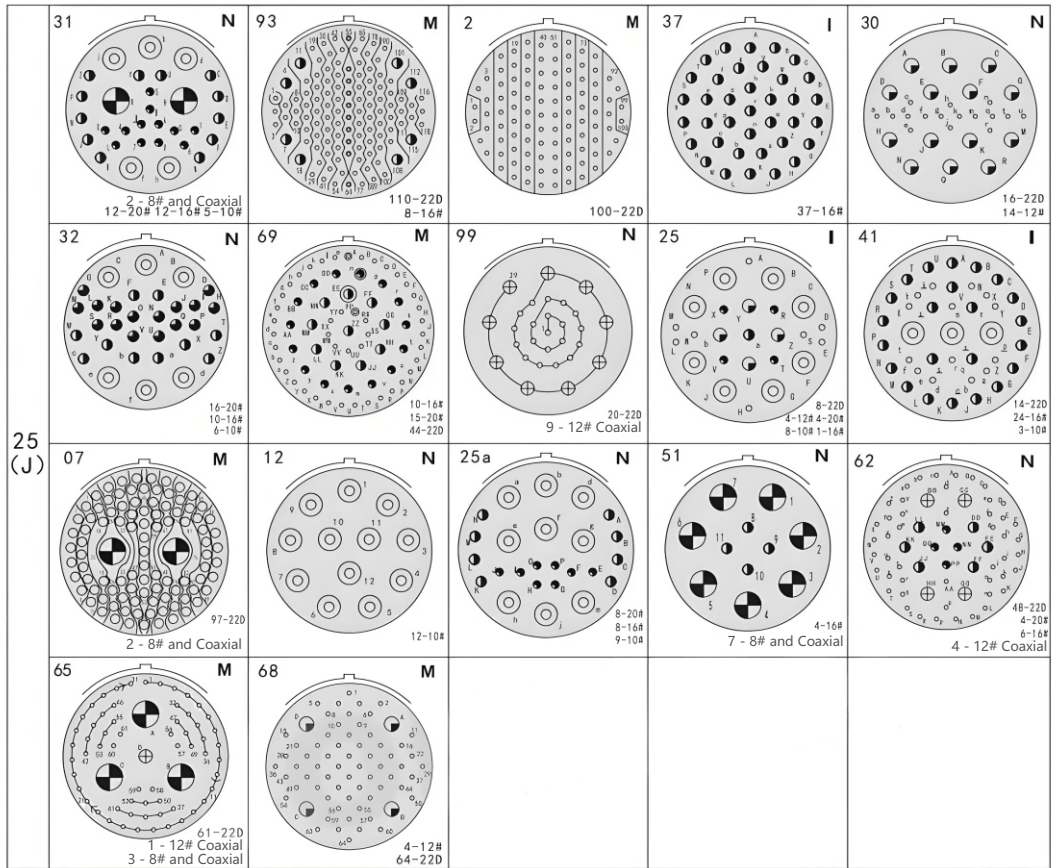

Power Contact Component Specifications

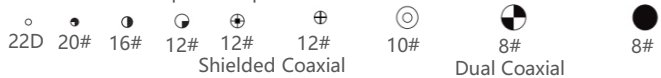

Shell Key Position

	N	A	B	C	D				
Socket keying angle									
Plug keying angle									
Key Position Code	09	11	13	15	17	19	21	23	25
N	95°	95°	95°	95°	95°	95°	95°	95°	95°
A		77°	81°	75°	74°	77°	77°	77°	80°
B		None	67°	63°	61°	65°	65°	65°	69°
C		None	123°	127°	129°	125°	125°	125°	121°
D		113°	109°	115°	116°	113°	113°	113°	110°

GJB599 Series I (MIL-DTL-38999 Series I) Electrical Connector

External Dimensions
 [Plug JY27467] (Knurling and Safety Hole Types for Reference Only)

	Shell Number	D1	Thread D2UNEF-2A
	09	21.7	0.4375-28
	11	25.0	0.5625-24
	13	28.2	0.6875-24
	15	31.3	0.8125-20
	17	34.4	0.9375-20
	19	37.4	1.0625-18
	21	40.5	1.1875-18
	23	44.0	1.3125-18
25	46.8	1.4375-18	

[Nut Mounted Socket JY27468] (When the model is marked with -S, the thread at the locking nut is left-hand thread, and six safety holes are evenly distributed around the circumference of the locking nut.)

	Shell Number	D1	Thread D2UNEF-2A	D3	K	B	S	d	P
	09	14.6	0.4375-28	30.2	2.8	27.0	22.3	17.7	17.0
	11	17.8	0.5625-24	35.0	2.8	31.8	25.5	21.0	19.6
	13	21.6	0.6875-24	38.1	2.8	35.0	30.2	25.6	24.3
	15	24.8	0.8125-20	41.3	2.8	38.1	33.4	28.8	27.6
	17	28.0	0.9375-20	44.5	2.8	41.3	36.6	32.0	30.7
	19	30.7	1.0625-18	49.3	3.6	46.0	39.7	35.2	33.9
	21	33.8	1.1875-18	52.4	3.6	49.2	42.9	38.3	37.1
	23	37.0	1.3125-18	55.6	3.6	52.4	46.1	41.5	40.0
	25	40.2	1.4375-18	58.8	3.6	55.6	50.8	44.7	43.4

[Wall-Mounted Square Flange Socket JY27466 JY27656] (When the model is marked with -S, each socket is equipped with 5 aviation standard screws with safety holes, flat washers and spring washers.)

<p>Wall-Mounted Square Flange Front-Mounted Socket (Jy27466)</p>		
--	--	--

GJB599 Series I (MIL-DTL-38999 Series I) Electrical Connector

GJB599 Series I (MIL-DTL-38999 Series I) Electrical Connector

Shell Number	D1	Thread D2UNEF-2A	A1	A2	K	B	E	T	d1	d2
09	14.6	0.4375-28	16.1	20.9	2.4	23.8	18.26	3.2	12.5	16.7
11	17.8	0.5625-24	16.1	20.9	2.4	26.2	20.62	3.2	15.5	20.2
13	21.6	0.6875-24	16.1	20.9	2.4	28.6	23.02	3.2	19.5	24.5
15	24.8	0.8125-20	16.1	20.9	2.4	31.0	24.62	3.2	21.5	27.7
17	28.0	0.9375-20	16.1	20.9	2.4	33.3	26.98	3.2	25.0	30.9
19	30.7	1.0625-18	16.1	20.9	2.4	36.5	29.36	3.2	28.0	32.9
21	33.8	1.1875-18	15.3	20.1	2.4	39.7	31.76	3.2	31.5	36.2
23	37.0	1.3125-18	15.3	20.1	3.1	42.9	34.92	3.7	34.5	39.3
25	40.2	1.4375-18	15.3	20.1	3.1	46.0	38.10	3.7	37.5	42.5

[Box-Type Square Flange Socket JY27496 JY27505] (When the model is marked with -S, each socket is equipped with 5 aviation standard screws with safety holes, flat washers and spring washers.)

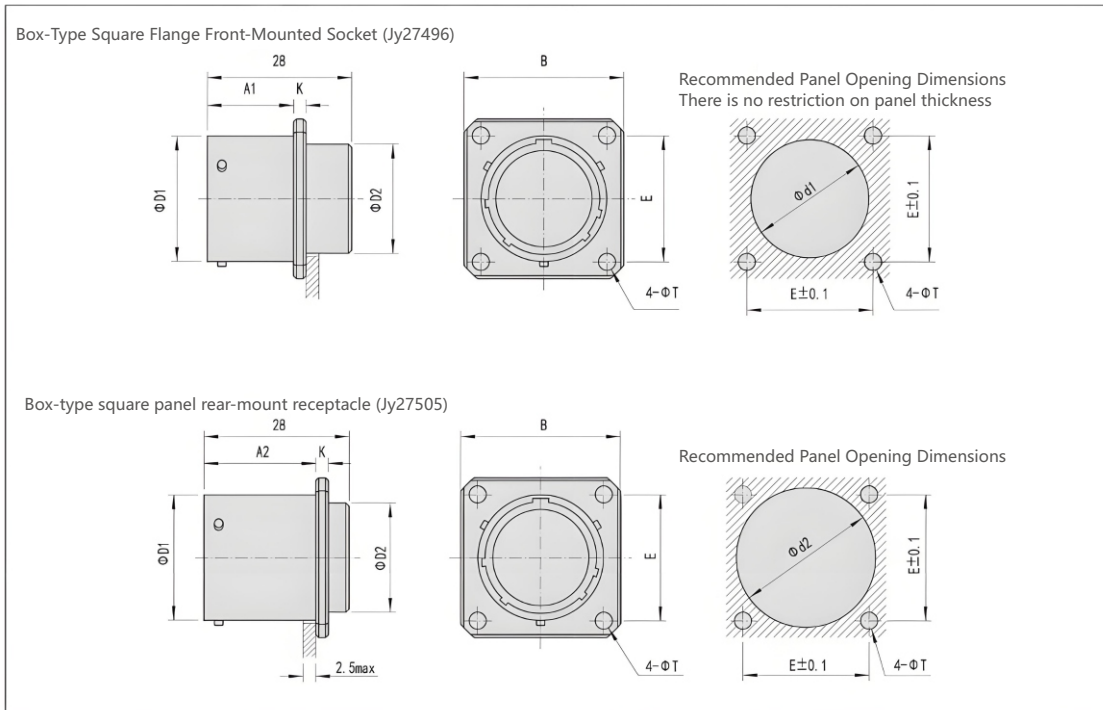

GJB599 Series I (MIL-DTL-38999 Series I) Electrical Connector

Housing Number	D1	D2	A1	A2	K	B	E	T	d1	d2
09	14.6	11.2	16.1	20.9	2.4	23.8	18.26	3.2	12.5	16.7
11	17.8	14.5	16.1	20.9	2.4	26.2	20.62	3.2	15.5	20.2
13	21.6	18.0	16.1	20.9	2.4	28.6	23.02	3.2	19.5	24.5
15	24.8	20.5	16.1	20.9	2.4	31.0	24.62	3.2	21.5	27.7
17	28.0	23.8	16.1	20.9	2.4	33.3	26.98	3.2	25.0	30.9
19	30.7	26.5	16.1	20.9	2.4	36.5	29.36	3.2	28.0	32.9
21	33.8	29.7	15.3	20.1	3.1	39.7	31.76	3.2	31.5	36.2
23	37.0	32.8	15.3	20.1	3.1	42.9	34.92	3.7	34.5	39.3
25	40.2	36.0	15.3	20.1	3.1	46.0	38.10	3.7	37.5	42.5

[Socket with Printed Board Type Contacts of GJB599 Series I]

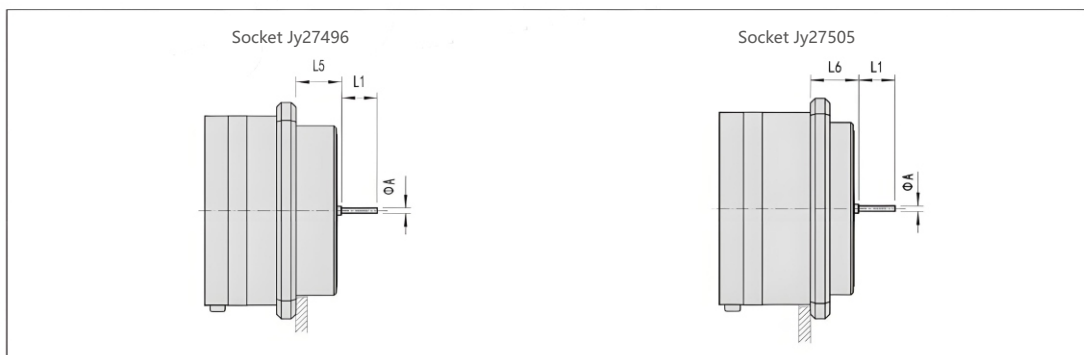
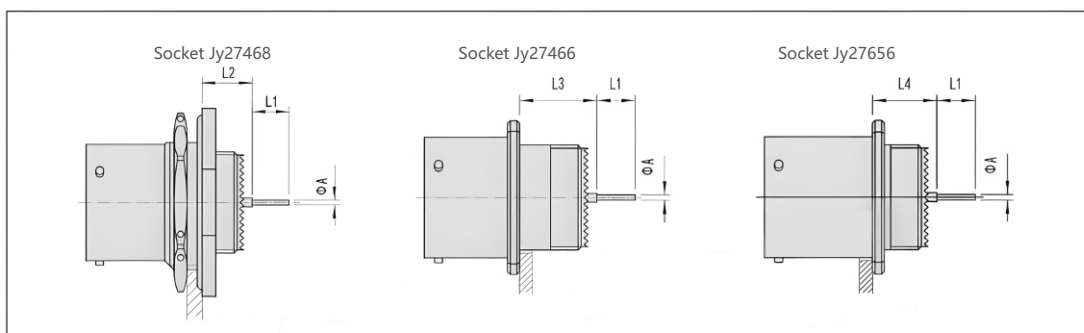

Specification of Printed Board Contact		L1	A
22D	Long Printed Board Contact	8.5	0.7
	Short Printed Board Contact	4.0	
20#	Long Printed Board Contact	8.5	0.7
	Short Printed Board Contact	5.0	
16#	Long Printed Board Contact	8.5	1.15
	Short Printed Board Contact	5.0	

GJB599 Series I (MIL-DTL-38999 Series I) Electrical Connector

GJB599 Series I (MIL-DTL-38999 Series I) Electrical Connector

Dimensions When Installing Contacts of Different Specifications		Housing Numbers 09-11-13-15-17-19		Housing Numbers 21-23-25	
L2	When Installing 22D Pin	max	10.06	10.06	
		min	9.06	9.06	
	When Installing 22D Socket Hole	max	10.06	10.06	
		min	8.74	8.74	
	When Installing 20# or 16# Pin, Socket Hole	max	10.23	10.23	
		min	9.24	9.24	
L3	When Installing 22D Pin	max	15.08	15.08	
		min	13.91	13.91	
	When Installing 22D Socket Hole	max	15.08	15.08	
		min	13.58	13.58	
	When Installing 20# or 16# Pin, Socket Hole	max	15.25	15.25	
		min	14.08	14.08	
L4	When Installing 22D Pin	max	12.47	13.22	
		min	11.60	12.35	
	When Installing 22D Socket Hole	max	12.47	13.22	
		min	11.27	12.02	
	When Installing 20# or 16# Pin, Socket Hole	max	12.64	13.39	
		min	11.77	12.52	
L5	When Installing 22D Pin	max	11.08	11.08	
		min	9.91	9.91	
	When Installing 22D Socket Hole	max	11.08	11.08	
		min	9.58	9.58	
	When Installing 20# or 16# Pin, Socket Hole	max	11.25	11.25	
		min	10.08	10.08	
L6	When Installing 22D Pin	max	8.47	9.22	
		min	7.60	8.35	
	When Installing 22D Socket Hole	max	8.47	9.22	
		min	7.27	8.02	
	When Installing 20# or 16# Pin, Socket Hole	max	8.64	9.39	
		min	7.77	8.52	

[Outline Dimensions of GJB599 Series I Welding Products]

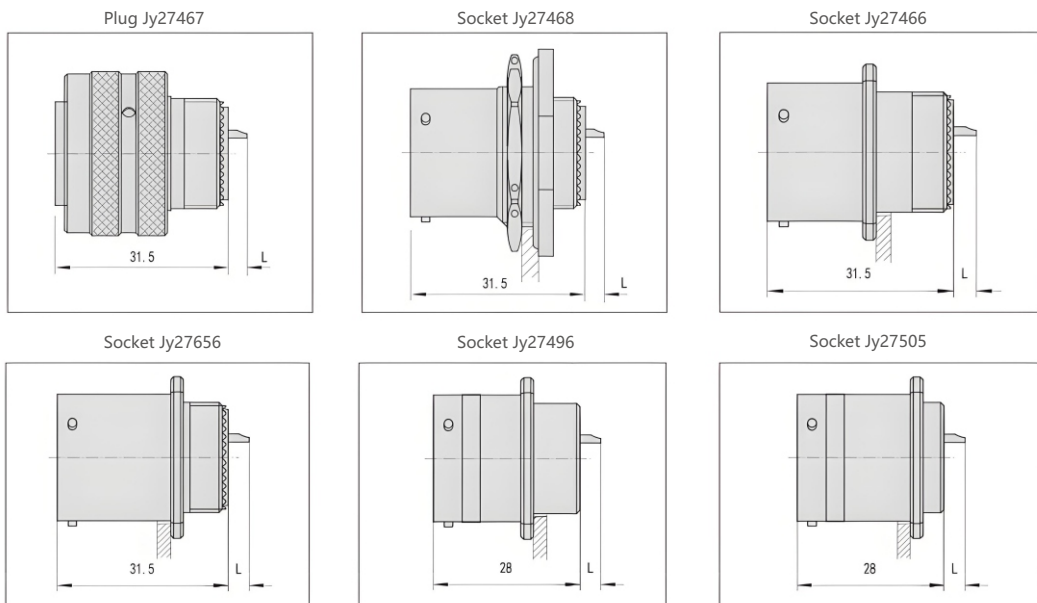

GJB599 Series I (MIL-DTL-38999 Series I) Electrical Connector

Welding Type Contact Specification	L	Inner Diameter of Wire Welding Cup	Maximum Compatible Wire Gauge (AWG)
22D	4	φ0.9	22
20#	4	φ1.1	20
16#	4	φ1.9	16
12#	4	φ2.9	12
10#	6	φ3.6	10
8#	6	φ4.8	8

Note: Coaxial contacts have no welding type contacts. [Dimensions After Plug and Socket Mating]

[Shell Key Position]

Wall-Mounted Front-Panel Socket (JY27466)/Plug (Jy27467)

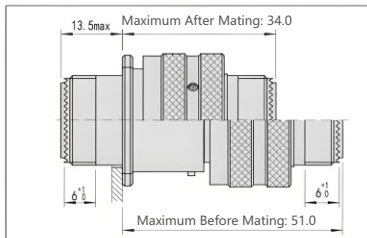

Wall-Mounted Rear-Panel Socket (JY27656)/Plug (Jy27467)

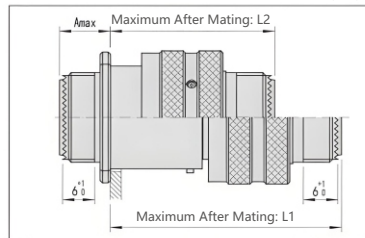

Box-Type Front-Panel Socket (JY27496)/Plug (Jy27467)

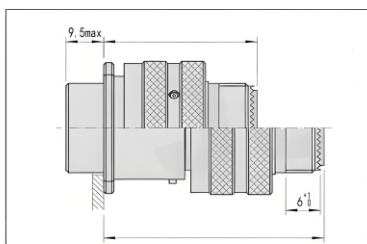

Box-Type Rear-Panel Socket (JY27505)/Plug (Jy27467)

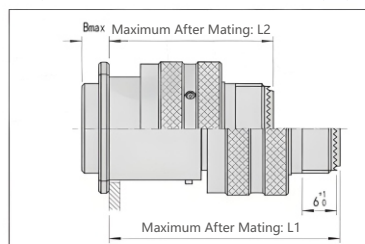

Nut-Mounted Socket (JY27468)/Plug (Jy27467)

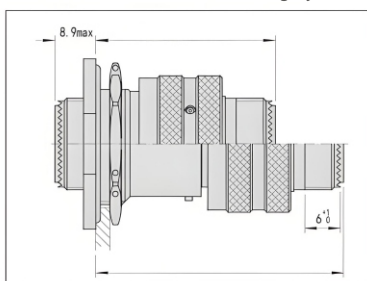

Note: For head sockets that can be equipped with tail accessories, the total length after connecting the accessories is the sum of the total length of the head socket and the total length of the accessories minus the combined length of the threads (i.e., the thread length).

Housing Number		09	11	13	15	17	19	21	23	25
L1	max	53.3	53.3	53.3	53.3	53.3	53.3	52.5	52.5	52.5
L2	max	36.4	36.4	36.4	36.4	36.4	36.4	35.6	35.6	35.6
A	max	11.1	11.1	11.1	11.1	11.1	11.1	11.9	11.9	11.9
B	max	7.1	7.1	7.1	7.1	7.1	7.1	7.9	7.9	7.9

GJB599 Series I (MIL-DTL-38999 Series I) Electrical Connector

GJB599 Series I (MIL-DTL-38999 Series I) Electrical Connector

Plug and Socket Sealing Caps

[Operating Temperature]

Metal Dust Caps:

Type B: -65°C~+175°C

Type F, E: -65°C~+200°C

Composite Material Dust Caps:

Type F, B: -40°C~+85°C

Note: Sealing caps shall be ordered separately and are not supplied with the connectors.

[Model Nomenclature for Plug Dust Caps]

Series Main Name	JY	27501	F	11	C	L
Type	JY27501 - Plug Sealing Cap (Corresponding to US Military Standard Part No. Ms27501)					
Shell Plating	B - Cadmium Plated Olive Drab; F - Electroless Nickel Plating; E - Stainless Steel Passivation					
Shell Number	09-11-13-15-17-19-21-23-25					
Chain Type	A - Without Chain; C - Stainless Steel Twisted Chain with Connecting Piece; N - Stainless Steel Twisted Chain with Ring R - Nylon Rope with Connecting Piece; S - Stainless Steel Wire Rope with Connecting Piece; E - Nylon Rope with Ring					
Length Marking	No Mark - Standard Length L - Chain Length 127mm M - Chain Length 152.4mm N - Chain Length 177.8mm					

Note: JY27501 dust caps are only of metal type.

[External Dimensions]

Plug Sealing Cap Jy27501 (Ms27501)		Type C								Type A	
Shell Number		09	11	13	15	17	19	21	23	25	
A	max	20.5	23.7	26.9	30.1	33.2	36.4	39.6	42.8	45.9	
H	max	76.2	76.2	88.9	88.9	88.9	88.9	101.6	101.6	101.6	

GJB599 Series I (MIL-DTL-38999 Series I) Electrical Connector

[Model Nomenclature for Receptacle Dust Caps]

Series Main Name	JY	27502	F	11	C	L	(J)
Type	JY27502 - Receptacle Sealing Cap (Corresponding to US Military Standard Part No. Ms27502)						
Shell Plating	B - Cadmium Plated Olive Drab; F - Electroless Nickel Plating; E - Stainless Steel Passivation						
Shell Number	09-11-13-15-17-19-21-23-25						
Chain Type	A - Without Chain; C - Stainless Steel Twisted Chain with Connecting Piece; N - Stainless Steel Twisted Chain with Ring R - Nylon Rope with Connecting Piece; S - Stainless Steel Wire Rope with Connecting Piece; E - Nylon Rope with Ring						
Length Marking	No Mark - Standard Length L - Chain Length 127mm						
Dust Cap Material Mark	(J) - Metal Shell No Mark - Composite Shell (Only for B, F Plating)						

Note: When there is no (J) after the JY27502 model, it is a composite material sealing cap.
When there is no plating, it is indicated by "-" in the model.

[Model Marking Examples]

JY27502F17C(J): JY27502 receptacle sealing cap, aluminum alloy nickel-plated, shell number 17, stainless steel twisted chain with connecting piece.

[External Dimensions]

Receptacle Sealing Cap
(Composite Material)
JY27502 (Ms27502)

(J)

A类

Shell Number		09	11	13	15	17	19	21	23	25
D	max	21.7	23.5	29.0	31.6	34.8	38.0	41.1	44.2	46.0
D1	max	20.2	23.4	27.4	30.6	34	36.9	40.1	43.1	46.4
d	min	18.0	21.1	26.0	29.0	32.4	35.5	38.6	42.0	44.7
H	max	76.2	76.2	88.9	88.9	88.9	88.9	101.6	101.6	101.6
L	max	18.9	18.9	18.9	18.9	18.9	18.9	18.9	18.9	19.7

GJB599 Series I (MIL-DTL-38999 Series I) Electrical Connector

GJB599 Series I (MIL-DTL-38999 Series I) Electrical Connector

Standard Rear Accessories (Applicable to GJB599 Series I and Series II Electrical Connectors)

This type of accessory complies with the national military standard GJB 1784 (equivalent to the U.S. military standard MIL-C-85049).

Notes:

(1) "J1784" and "J1784 A" mentioned in the following accessory models are identical and have no distinction.

(2) When using the accessories, at least one of the following anti-loosening measures should be taken:

- ① Pass a fuse through the insurance hole for anti-loosening;
- ② Apply threadlocker to the rear thread of the product and then tighten the connecting nut for anti-loosening;
- ③ Use a heat-shrinkable tube to heat-shrink the entire accessory for anti-loosening.

(3) For accessories with set screws, apply threadlocker to the set screw before tightening it.

(4) If the product adapted to the cable accessory is equipped with a No. 8 contact, please select a longer cable accessory such as J1784/49H or J1784/18A to avoid interference between the contact locator and the cable accessory.

(5) The following table lists the correspondence between GJB599 series welded and crimped products and adapted cable accessories, as well as the functional classification of cable accessories. Due to the large number of modified products and accessory types of our company at present, they cannot be listed one by one. The content of this table is for reference only. Please contact our company for detailed information.

Connector Type	Adapted Cable Accessory Function Types	Adapted Cable Accessory Models
GJB599I, II Series Crimp Type Connector	Cable Accessories Without Cable Clamping and Without Shielding	1. J1784/27, HA Type
	Cable Accessories With Cable Clamping and Without Shielding	1. J1784/49, HB Type
		2. J1784/49-xx (Short)
		3. J1784/47, HC Type
	Cable Accessories With Shielding and Without Cable Clamping	1. TJI784/62, HD Type
		2. J1784/62
		3. J1784/85
		4. J1784/87
		5. JY599 I -FJA00
		6. JY599 I -FJA90
		7. JY599 I xxFJC00
		8. JY599 I xxFJE00
Cable Accessories With Cable Clamping and With Shielding	1. TJI784/62-xxB, HE Type	
	2. TJI784/62-xxC-xx	
	3. J1784/18A Series	
GJB599I, II Series Welding Type Connector	Cable Accessories Without Cable Clamping and Without Shielding	1. J1784/27, HA Type
	Cable Accessories With Cable Clamping and Without Shielding	1. J1784/49H
		2. J1784/47, HC Type
	Cable Accessories With Shielding and Without Cable Clamping	1. TJI784/62, HD Type
		2. J1784/62
		3. J1784/85
		4. J1784/87
		5. JY599 I -FJA00
		6. JY599 I -FJA90
	Cable Accessories With Cable Clamping and With Shielding	1. TJI784/62-xxB, HE Type
		2. TJI784/62-xxC-xx
		3. J1784/18A Series

GJB599 Series I (MIL-DTL-38999 Series I) Electrical Connector

[GJB1784 Model Naming]

Series Main Name	J1784/	27-	14	N					
Type	27 - Type ANylon Cap (Cable Accessories Without Cable Clamping and Without Shielding) 49 - Type BStraight Cable Clamp (Cable Accessories With Cable Clamping and Without Shielding) 47 - Type CBent Cable Clamp (Cable Accessories With Cable Clamping and Without Shielding) 62 - Type DShielded Termination Accessory (Add "T" before the basic part number) (Cable Accessories With Shielding and Without Cable Clamping) 62 - Heat Shrinkable Sleeve Termination Accessory (Cable Accessories With Shielding and Without Cable Clamping)								
Accessory Housing Number	08	10	12	14	16	18	20	22	24
Matching GJB599 Series I Housing Number	09	11	13	15	17	19	21	23	25
Matching GJB599 Series II Housing Number	08	10	12	14	16	18	20	22	24
Housing Plating	W - Cadmium Plated Military Green N - Electroless Nickel Plating S - Stainless Steel Passivation FT - Aluminum Alloy Plated with Polished Nickel TA - Titanium Alloy								

Note: ① In the model naming of the national military standard GJB 1784 and the US military standard MIL-C-85049, except for the difference in the basic part number, the rest are completely the same. The basic part number of GJB 1784 is "J1784", and the main designation of MIL-C-85049 is "M85049", and they are interchangeable.

② The housing numbers of the above cable accessories shall be even numbers, and odd numbers are strictly prohibited from being used as housing numbers.

[Nomenclature of Models in the Industry]

Type	HACartridge-Type Rear Accessory	HBStraight Cable-Clamping Rear Accessory	HC90° Bent Cable-Clamping Rear Accessory	HDSHielded Rear Accessory	HEStraight Cable-Clamping SHielded Rear Accessory	HA-	F	18	
Housing Plating	B - Cadmium Plated Military Green F - Electroless Nickel Plating S - Stainless Steel Passivation FT - Aluminum Alloy Plated with Polished Nickel TA - Titanium Alloy								
Accessory Housing Number	08	10	12	14	16	18	20	22	24
Matching GJB599 Series I Housing Number	09	11	13	15	17	19	21	23	25
Matching GJB599 Series II Housing Number	08	10	12	14	16	18	20	22	24

[Model Comparison]

GJB1784 Accessory Model	Accessory Models in the Industry
J1784/27-×W J1784/27-×N	HA-B× HA-F×
J1784/49-×W J1784/49-×N	HB-B× HB-F×
J1784/47-×W J1784/47-×N	HC-B× HC-F×
TJ1784/62-×W TJ1784/62-×N	HD-B× HD-F×
TJ1784/62-×WB TJ1784/62-×NB	HE-B× HE-F×

(In the table, "×" represents the housing number. It is recommended that users place orders according to the GJB1784 accessory models first, and can place orders according to the accessory models in the industry when necessary.)

GJB599 Series I (MIL-DTL-38999 Series I) Electrical Connector

[Overall Dimensions]

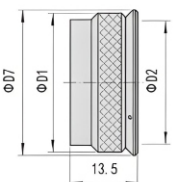
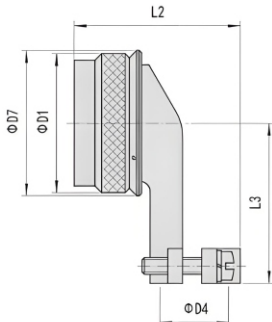
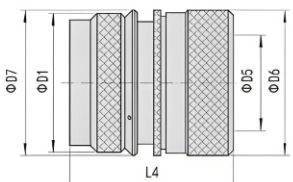
J1784/27- (HA Type) Tail Nut	J1784/47- (HC Type) Angled Cable Clip	TJ1784/62- (HD Type) Shielded Termination Tail Accessory
		
<p>Anti-rotation accessory, tightly sealing the cable body to ensure the environmental resistance of the connector. It cannot clamp cables and is used in general environmental conditions.</p>	<p>Anti-rotation, 90° cable clamping accessory. It can tightly seal the cable body and clamp the cable at 90°, ensuring the environmental resistance of the connector, and is used in situations where the cable is subject to tension.</p>	<p>Anti-rotation, shield mesh compressing accessory. It can tightly seal the cable body and provide the connection function between the shield mesh and the tail accessory, ensuring the electromagnetic shielding performance of the connector, and is used in situations where the cable is subject to small tension.</p>

Housing Number		08	10	12	14	16	18	20	22	24
D1	max	15.6	18.6	21.8	25.0	28.2	31.0	34.2	37.3	40.5
D2	max	7.9	10.8	13.6	16.9	20.1	22.4	25.6	28.8	31.9
	min	3.2	4.0	4.8	5.5	6.4	7.9	9.5	10.3	14.3
D4	max	6.4	9.5	11.1	14.3	15.9	19.1	22.2	23.8	25.4
D5	max	7.0	9.7	12.8	14.9	18.0	20.0	23.2	26.3	28.9
D6	max	17.0	19.9	23.1	26.3	29.5	32.5	35.7	38.9	42.0
D7	max	16.9	19.9	23.1	26.3	29.5	32.3	35.5	38.6	41.8
L2	max	29.0	32.0	33.5	36.5	38.5	41.5	44.5	46.0	48.0
L3	max	25.0	26.0	27.5	31.0	32.5	34.0	34.5	36.5	43.5
L4	max	31.2	31.2	31.2	33.2	33.2	33.2	36.2	36.2	36.2

GJB599 Series I (MIL-DTL-38999 Series I) Electrical Connector

[J1784/49--Straight Cable Clip] (HB Type) (When (S) and (M) are added after the model, the outlet value D changes accordingly. (S) and (M) are reflected in the product marking, for example, the outlet diameter of J1784/49-12W (M) is 4.83~6.58)

Housing No	D7 (max)	F (max)	Model with (S) Added		Model with (M) Added		Normal Model		L (max)
			D	Screw Length	D	Screw Length	D	Screw Length	
08	16.9	20.0	4.49	M3.5*12	None	None	2.49~5.94	M3.5*14	23.4
10	19.9	20.0	5.47	M3.5*12	None	None	3.87~5.94	M3.5*14	23.4
12	23.1	23.4	4.83	M3.5*12	4.83~6.58	M3.5*14	4.83~8.33	M3.5*16	23.4
14	26.3	26.6	6.60	M3.5*12	6.60~9.11	M3.5*15	6.60~11.61	M3.5*20	27.8
16	29.5	30.6	7.19	M3.5*12	7.19~11.40	M3.5*16	7.19~15.60	M3.5*20	27.8
18	32.3	34.0	8.26	M4*14	8.26~13.16	M4*18	8.26~16.10	M4*20	27.8
20	35.5	35.8	8.71	M4*14	8.71~13.61	M4*18	8.71~17.73	M4*25	27.8
22	38.6	39.0	9.68	M4*14	9.68~16.58	M4*20	9.68~20.90	M4*25	29.9
24	41.8	40.6	10.62	M4*14	10.62~17.42	M4*20	10.62~21.66	M4*30	29.9

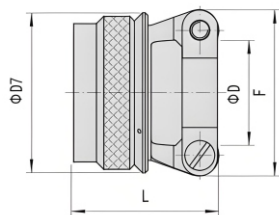

Anti-rotation and cable clamping accessory. It can tighten the sealing body and clamp the cable, ensuring the environmental resistance performance of the connector, and is used in scenarios where the cable is subject to tension.

[J1784/62--Heat Shrinkable Sleeve Tail Accessory]

(Shielded Non-Clamping Cable Accessory)	Model	D1	D2	D3
	J1784/62-08N	16.9	7.9	11.6
	J1784/62-10N	19.9	10.9	14.7
	J1784/62-12N	23.1	13.7	17.6
	J1784/62-14N	26.3	16.9	21.2
	J1784/62-16N	29.5	20.1	24.4
	J1784/62-18N	32.3	22.5	26.4
	J1784/62-20N	35.5	25.4	30.9
	J1784/62-22N	38.6	28.5	33.8
	J1784/62-24N	41.8	31.6	36.9

Anti-rotation and shield mesh compression accessory. It can tighten the sealing body and provide the function of connecting the shield mesh with the tail accessory, ensuring the environmental resistance and electromagnetic shielding performance of the connector. It cannot clamp the cable and is used in scenarios where the cable tension is small.

[J1784/49H--Welded Straight Cable Clip]

(Clamping Cable Non-Shielding Accessory)	Model	A (max)	C	L (max)	D
	J1784/49H-08N	18.0	20.0	26.4	2.49~5.94
	J1784/49H-10N	22.0	21.0	27.9	3.87~5.94
	J1784/49H-12N	25.1	23.4	29.4	4.83~8.33
	J1784/49H-14N	29.0	26.6	30.9	6.6~11.61
	J1784/49H-16N	32.1	30.6	33.1	7.19~15.6
	J1784/49H-18N	35.1	34.0	36.2	8.26~16.1
	J1784/49H-20N	38.1	35.8	39.4	8.71~17.73
	J1784/49H-22N	41.1	39.0	42.5	9.68~20.9
	J1784/49H-24N	44.1	40.6	44.6	10.62~21.66

It has the same function as J1784/49 and is matched with welded products.

GJB599 Series I (MIL-DTL-38999 Series I) Electrical Connector

[J1784/49—x × N (Short)]

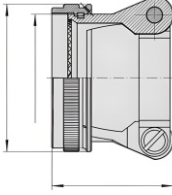
(Clamping Cable Non-Shielding Accessory)	Accessory Model	D1	Thread D2	L1	Outlet Diameter
 <p>Anti-rotation and cable-clamping cable accessory. It can tighten the sealing body and clamp the cable, ensuring the environmental resistance of the connector, and is used in scenarios where the cable is under tension. Its length is relatively shorter than that of the J1784/49 accessory.</p>	J1784/49-10N (Short)	19.5	0.5625-24	20.8	5.1~10
	J1784/49-12N (Short)	22.6	0.6875-24	19	6.7~12.9
	J1784/49-14N (Short)	25.8	0.8125-20	25.2	8.4~16
	J1784/49-16N (Short)	29	0.9375-20	25.3	9.2~18.5
	J1784/49-18N (Short)	32.2	1.0625-18	26.7	10~21.5
	J1784/49-20N (Short)	35.3	1.1875-18	26.8	11.2~24.75
	J1784/49-22N (Short)	38.5	1.3125-18	32	11.6~22.6

[TJ1784/62-NB (HE Type) Straight Clamping Shielded Rear Accessory]

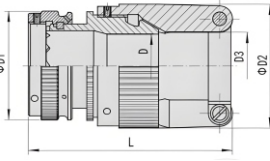
(Clamping Cable and Shielding Accessory)	Model	D	D1	D2	D3	L
 <p>Anti-rotation, shield mesh compression and cable-clamping cable accessory. It can tighten the sealing body, provide the function of connecting the shield mesh with the tail accessory and clamp the cable, ensuring the electromagnetic shielding performance of the connector, and is used in scenarios where the cable is under tension.</p>	TJ1784/62-08NB	6.5	16.3	19.4	6.8	39.0
	TJ1784/62-10NB	9.7	19.5	22.5	9.2	39.0
	TJ1784/62-12NB	12.8	22.6	25.7	12.6	39.0
	TJ1784/62-14NB	14.9	25.8	28.9	16	45.0
	TJ1784/62-16NB	18	29.0	32.1	17.5	45.0
	TJ1784/62-18NB	20	32.2	35.3	21.5	46.5
	TJ1784/62-20NB	23.2	35.3	38.4	24.8	51.3
	TJ1784/62-22NB	26.3	38.5	41.6	22.6	56.6
	TJ1784/62-24NB	28.9	41.7	44.8	23.1	57.3

[TJ1784/62- x × NC- x ×]

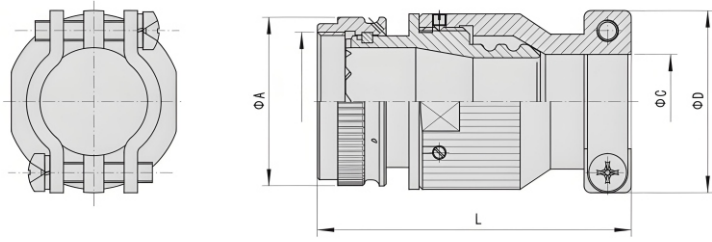
(Clamping Cable and Shielding Accessory)
 <p>Anti-rotation, compression shielding mesh and clamping wire cable accessory. It can tightly hoop the cable body, provide the connection function between the shielding mesh and the tail accessory, and the cable clamping function, ensure the electromagnetic shielding performance of the connector, and be used in situations where the cable is under tension.</p>

GJB599 Series I (MIL-DTL-38999 Series I) Electrical Connector

Accessory Model	A	Thread B UNEF	C	D	L
TJ1784/62-08NC-08	16.3	0.4375-28	8	20	39.7
TJ1784/62-10NC-08	19.5	0.5625-24	8	20	39.7
TJ1784/62-10NC-10			10	20	40.7
TJ1784/62-12NC-10	22.6	0.6875-24	10	20	40.7
TJ1784/62-12NC-12			12	25	47.4
TJ1784/62-14NC-12	25.8	0.6875-24	12	25	47.4
TJ1784/62-14NC-14			14	27	47.4
TJ1784/62-14NC-16			16	27	47.4
TJ1784/62-16NC-16	29	0.9375-20	16	27	47.4
TJ1784/62-16NC-19			19	32	47.4
TJ1784/62-18NC-19	32.2	1.0625-18	19	32	47.4
TJ1784/62-18NC-22			22	33	47.4
TJ1784/62-20NC-22	35.3	1.1875-18	22	33	47.4
TJ1784/62-20NC-25			25	36.5	47.4
TJ1784/62-22NC-25	38.5	1.3125-18	25	36.5	47.4
TJ1784/62-22NC-28			28	40	47.4
TJ1784/62-24NC-28	41.7	1.4375-18	28	40	47.4
TJ1784/62-24NC-31			31	44	47.4

[Model Naming]

J1784/18A Series (Cable Clamping and Shielding Accessory)

Series Main Name	J1784/	18A-	25	N	09	A
Type	18A-Straight Shielded Cable Clamp (Suitable for GJB599 Series I, II)					
Shell Number	See Table 1					
Shell Plating	N-Chemical Nickel Plating W-Cadmium Plated Military Green S-Stainless Steel Passivation FT-Aluminum Alloy Plated Forged Nickel TA-Titanium Alloy					
Outlet Diameter Number	Please select according to Table 1 and Table 2					
Length Code	See Table 3					

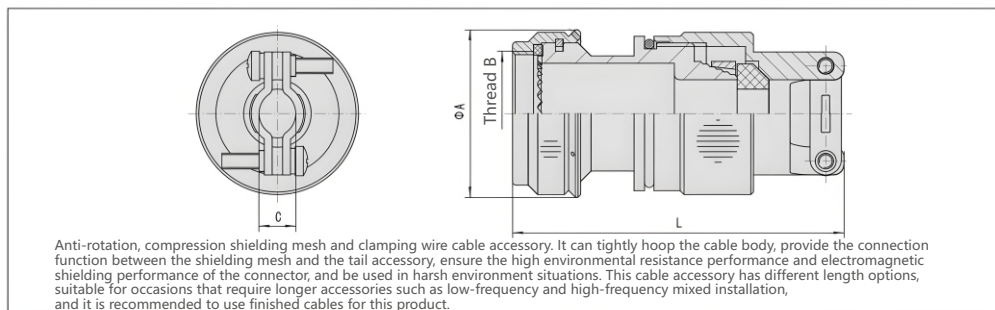

GJB599 Series I (MIL-DTL-38999 Series I) Electrical Connector

Table 1

Shell Number	Optional Outlet Diameter Numbers for Each Shell Number	A	Thread B
09	01~02	18	0.4375-28UNEF
11	01~03	22	0.5625-24UNEF
13	02~04	25	0.6875-24UNEF
15	02~05	28	0.8125-20UNEF
17	02~06	32	0.9375-20UNEF
19	03~07	35	1.0625-18UNEF
21	03~08	38	1.1875-18UNEF
23	03~09	41	1.3125-18UNEF
25	04~10	44	1.4375-18UNEF

Table 2

Outlet Diameter Number	Applicable Cable Diameter Range C
01	1.57~3.18
02	3.18~6.35
03	6.35~9.53
04	9.53~12.7
05	12.7~15.88
06	15.88~19.05
07	19.05~22.23
08	22.23~25.4
09	25.4~28.58
10	28.58~31.75

Table 3

Shell Number	Length Code	L
09~25	Standard (Omitted)	62.7
09~25	A	88.1
15~25	B	113.5
21~25	C	138.9

This type of tail accessory is particularly suitable for clamping shielded cables with shielding mesh, and is divided into two major categories: straight type and bent type. This accessory can be optionally equipped with a Ti-Ni alloy memory ring with alloy memory. By heating, it shrinks to tightly hoop the shielding mesh at the tail of the accessory, truly achieving 360° electromagnetic shielding.

Note: Heating and shrinking method of Ti-Ni alloy memory ring: It can be heated with a hot air gun, which takes about 45 seconds to 1 minute. When the temperature indicator on the memory ring changes from green to black, the memory ring has finished shrinking. At this time, the temperature of the ring is about 165°C, and heating should be stopped. Note that the memory ring should be heated evenly during heating.

[Model Naming]

J1784/85, J1784/87 External Shielding Tail Accessory (Shielding Non-Clamping Cable Accessory)

Series Main Name	J1784/	85-	10	N	A	-05			
Series Code	85-Straight Type, 87-Bent Type (Universal for GJB599 Series I, II)								
Accessory Shell Number	08	10	12	14	16	18	20	22	24
Matching Series I Shell Number	09	11	13	15	17	19	21	23	25
Matching Series II Shell Number	08	10	12	14	16	18	20	22	24
Shell Plating	W-Cadmium Plated Military Green N-Chemical Nickel Plating S-Stainless Steel Passivation FT-Aluminum Alloy Plated Forged Nickel TA-Titanium Alloy (Only for Type 85)								
Ti-Ni Ring	No Mark - No Ti-Ni Ring A - Optional Ti-Ni Ring								
Outlet Diameter or Ti-Ni Ring Specification	When there is no Ti-Ni ring, mark the outlet diameter When selecting Ti-Ni ring, mark the Ti-Ni ring specification								

GJB599 Series I (MIL-DTL-38999 Series I) Electrical Connector

JY599 I -FJA00, JY599 I -FJA90 External Shielding Tail Accessory (Shielding Non-Clamping Cable Accessory)

Series Main Name	Jy599	I	15	FJA	00	F	A	-05	
Series Code	I (Universal for GJB599 Series I, II)								
Accessory Shell Number	08	10	12	14	16	18	20	22	24
Matching Series I Shell Number	09	11	13	15	17	19	21	23	25
Matching Series II Shell Number	08	10	12	14	16	18	20	22	24
Accessory Type	FJA, FJC, FJE								
Structural Form	00 - Straight Tail Accessory 90 - 90° Bent Accessory								
Shell Plating	B - Cadmium Plated Military Green E - Stainless Steel Passivation F - Chemical Nickel Plating FT - Aluminum Alloy Plated Forged Nickel TA - Titanium Alloy (Only for Type 00)								
Ti-Ni Ring	No Mark - No Ti-Ni Ring A - Optional Ti-Ni Ring (Only for FJA, FJC)								
Outlet Diameter or Ti-Ni Ring Specification	When there is no Ti-Ni ring, mark the outlet diameter When selecting Ti-Ni ring, mark the Ti-Ni ring specification								

Note: 1. This type of accessory is used in harsh environments and occasions where frequent disassembly is not required. It can achieve internal and external shielding.
 2. If steel strapping is needed, the steel strap and strapping pliers need to be ordered separately. The steel strap is "Stainless Steel Strap A31189 (07-08-221)", and the strapping pliers are "Steel Strap Strapping Pliers A30199 TIE-DEX II (14-04-3216)".
 3. J1784/85, J1784/87 are the same as JY599 I -FJA00, JY599 I -FJA90, only the model naming is different.

Overall Dimensions

Straight Accessory (J1784/85 or JY599I-FJA00)

Bent Accessory (J1784/87 or JY599I-FJA90)

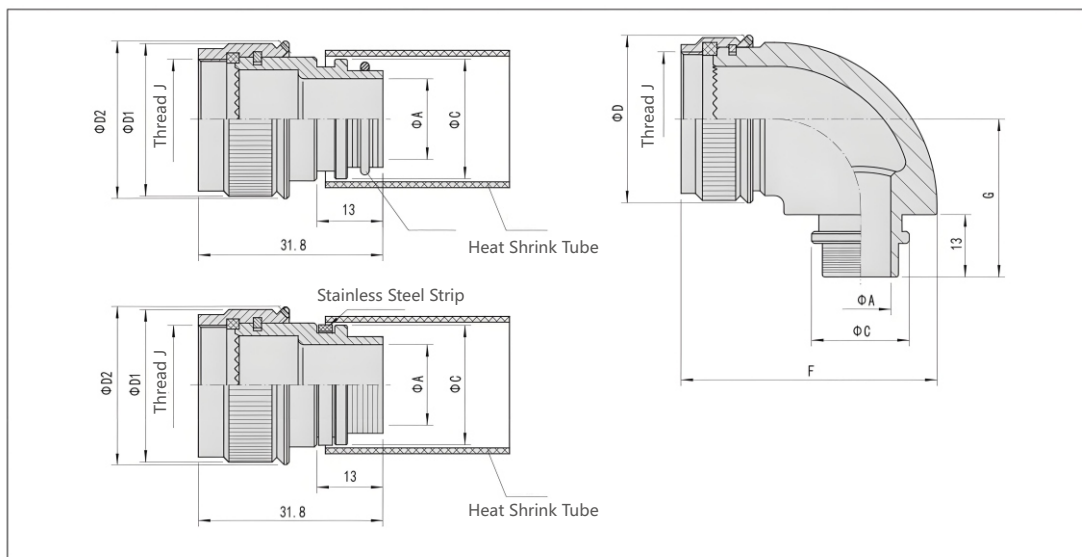

GJB599 Series I (MIL-DTL-38999 Series I) Electrical Connector

Serial Number	Shell Serial Number	Ti-Ni Ring Specification	Shield Mesh Specification (Diameter of Tinned Copper Wire)	Outlet Diameter ΦA		C		F	D1	D2	G	Thread J UNEF-2B
				Straight Type	Bent Type	Straight Type	Bent Type					
1	09	TR-04	6×10 (0.15~0.20)	6.3	6.3	14	14	36.3	17	18	26	0.4375-28
		TR-05	10×16 (0.15~0.20)	7.9	7.9	15.5	15					
		TR-06	10×16 (0.15~0.20)	9.5	9.5	17.1	15					
2	11	TR-04	6×10 (0.15~0.20)	6.3	6.3	14	14	37.8	21	22	26	0.5625-24
		TR-05	10×16 (0.15~0.20)	7.9	7.9	15.5	15.5					
		TR-06	10×16 (0.15~0.20)	9.5	9.5	17.1	17.1					
		TR-07	10×16 (0.12~0.20)	11.1	11.1	18.7	18					
3	13	TR-04	6×10 (0.15~0.20)	6.3	6.3	14	14	43.3	24	25	29	0.6875-24
		TR-05	10×16 (0.15~0.20)	7.9	7.9	15.5	15.5					
		TR-06	10×16 (0.15~0.20)	9.5	9.5	17.1	17.1					
		TR-07	10×16 (0.12~0.20)	11.1	11.1	18.7	18.7					
		TR-08	16×24 (0.12~0.25)	12.7	12.7	20.3	20.3					
		TR-10	16×24 (0.10~0.30)	16	16	23.5	23.0					
4	15	TR-05	10×16 (0.15~0.20)	7.9	None	15.5	None	45.1	27	28	29	0.8125-20
		TR-06	10×16 (0.15~0.20)	9.5	9.5	17.1	17.1					
		TR-07	10×16 (0.12~0.20)	11.1	11.1	18.7	18.7					
		TR-08	16×24 (0.12~0.25)	12.7	12.7	20.3	20.3					
		TR-10	16×24 (0.10~0.30)	16	16	23.5	23.5					
		TR-12	16×24 (0.10~0.30)	19	19	26.7	25.5					
5	17	TR-05	10×16 (0.15~0.20)	7.9	None	15.5	None	48.8	31	32	33	0.9375-20
		TR-06	10×16 (0.15~0.20)	9.5	10.5	17.1	17.1					
		TR-07	10×16 (0.12~0.20)	11.1	11.1	18.7	18.7					
		TR-08	16×24 (0.12~0.25)	12.7	12.7	20.3	20.3					
		TR-10	16×24 (0.10~0.30)	16	16	23.5	23.5					
		TR-12	16×24 (0.10~0.30)	19	19	26.7	26.7					
6	19	TR-08	16×24 (0.12~0.25)	12.7	12.7	20.3	20.3	51.6	34	35	33	1.0625-18
		TR-10	16×24 (0.10~0.30)	16	16	23.5	23.5					
		TR-12	16×24 (0.10~0.30)	19	19	26.7	26.7					
		TR-14	24×30 (0.10~0.30)	22.2	22.2	30	30					
		TR-16	24×30 (0.10~0.30)	25.4	25.4	33	32					
7	21	TR-08	16×24 (0.12~0.25)	12.7	12.7	20.3	20.3	53.8	37	38	39	1.1875-18
		TR-10	16×24 (0.10~0.30)	16	16	23.5	23.5					
		TR-12	16×24 (0.10~0.30)	19	19	26.7	26.7					
		TR-14	24×30 (0.10~0.30)	22.2	22.2	30	30					
		TR-16	24×30 (0.10~0.30)	25.4	25.4	33	33					
8	23	TR-18	30×40 (0.10~0.30)	28.5	None	36.2	None	56.3	40	41	39	1.3125-18
		TR-10	16×24 (0.10~0.30)	16	16	23.5	23.5					
		TR-12	16×24 (0.10~0.30)	19	19	26.7	26.7					
		TR-14	24×30 (0.10~0.30)	22.2	22.2	30	30					
		TR-16	24×30 (0.10~0.30)	25.4	25.4	33	33					
		TR-18	30×40 (0.10~0.30)	28.5	28.5	36.2	36.2					
9	25	TR-20	30×40 (0.10~0.30)	31.8	None	39.4	None	61.8	43	44	44	1.4375-18
		TR-10	16×24 (0.10~0.30)	16	16	23.5	None					
		TR-12	16×24 (0.10~0.30)	19	19	26.7	26.7					
		TR-14	24×30 (0.10~0.30)	22.2	22.2	30	30					
		TR-16	24×30 (0.10~0.30)	25.4	25.4	33	33					
		TR-18	30×40 (0.10~0.30)	28.5	28.5	36.2	36.2					

GJB599 Series I (MIL-DTL-38999 Series I) Electrical Connector

[JY599I xx FJC00] (Shielded Non - Clamping Cable Accessory)

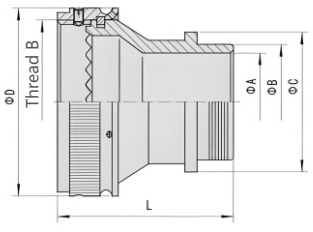
	Shell Number	A	B	C	D	Thread J UNEF	L	Ti-Ni Ring Gauge Specification
		11	8.3	11	15	18.6	0.5625—24	29
	13	10	12.7	16.6	21.8	0.6875—24	29	TR-06
	15	11.1	14.3	18.5	25	0.8125—20	29	TR-07
	17	13.1	15.9	19.8	28.2	0.9375—20	29	TR-08
	19	16.2	19	23	30.9	1.0625—18	29	TR-10
	21	16.2	19	23	34.1	1.1875—18	29	TR-10
	23	19.5	22.2	26.2	37.5	1.3125—18	29	TR-12
	25	19.5	22.2	26.2	40.5	1.4375—18	29	TR-12

[JY599I xx FJE00] (Shielded Non - Clamping Cable Accessory)

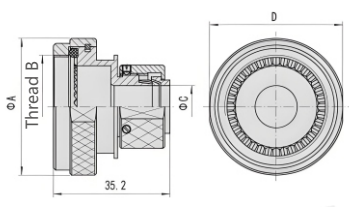
	Shell Number	A	Thread B UNEF	Outlet C Diameter	D
		09	22	0.4375—28	6.3, 7.9, 9.5
	11	25	0.5625—24	6.3, 7.9, 9.5, 11.1, 12.7	23
	13	28	0.6875—24	6.3, 7.9, 9.5, 11.1, 12.7, 16	27
	15	32	0.8125—20	7.9, 9.5, 11.1, 12.7, 16, 19	30
	17	35	0.9375—20	7.9, 9.5, 11.1, 12.7, 16, 19, 22.2	33
	23	44	1.3125—18	16, 19, 22.2, 25.4, 28.5, 31.8	42
	25	47	1.4375—18	19, 22.2, 25.4, 28.5, 31.8, 35	45

Square Plate Rubber Pad

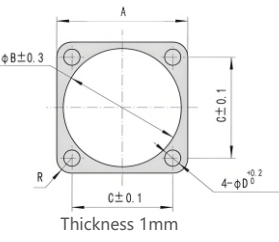
	Compatible Shell Number	Square Plate Rubber Pad Code	Square Plate Rubber Pad Code	A	B	C	D	R
		09	21E8-701-849-A1	21E8-701-850-A2	23.9	14.8	18.26	3.3
	11	21E8-701-851-A1	21E8-701-852-A2	26.3	18.0	20.62	3.3	3.2
	13	21E8-701-853-A1	21E8-701-854-A2	28.7	21.8	23.01	3.3	3.2
	15	21E8-701-855-A1	21E8-701-856-A2	31.1	25.0	24.61	3.3	3.2
	17	21E8-701-857-A1	21E8-701-858-A2	33.4	28.2	26.97	3.3	3.2
	19	21E8-701-859-A1	21E8-701-860-A2	36.6	30.9	29.36	3.3	3.2
	21	21E8-701-861-A1	21E8-701-862-A2	39.8	34.0	31.75	3.3	3.2
	23	21E8-701-863-A1	21E8-701-864-A2	43.0	37.2	34.93	3.8	3.7
	25	21E8-701-865-A1	21E8-701-866-A2	46.1	40.4	38.10	3.8	3.7

GJB599 Series I Cabinet-Type Floating (JYF) Electrical Connector



The pictures are for reference only

GJB599 Series I Cabinet-Type Floating (JYF) Electrical Connector

GJB599 Series I Cabinet-Type Floating (JYF) Electrical Connector

Product Introduction

- Product Introduction
- Electromagnetic interference shielding
- Shell grounding before contact insertion
- Lightweight and space-saving
- Shell sizes from 11# to 25#, totaling 8 types
- 100% anti-misinsertion contacts to prevent contact bending and short circuits during mating
- Contact counts from 1-core to 128-core
- Contact specifications: 22D, 20#, 16#, 12#, 8#, 4#
- Compatible with J1784 standard rear accessories
- Contact arrangement: Same as GJB599 Series I shells 11# ~ 25#



Product Features

JYF series connectors have sockets installed on the fixed unit of equipment and plugs on the mobile unit. The JYF series itself does not provide locking and unlocking mechanisms; these functions are provided by the equipment. Due to the floating design of the plug, JYF series connectors can coordinate the fit tolerance between the mobile and fixed units, absorbing deformations and offsets of the mobile unit caused by loads and other factors. The floating range of the plug is shown in Figure 1.

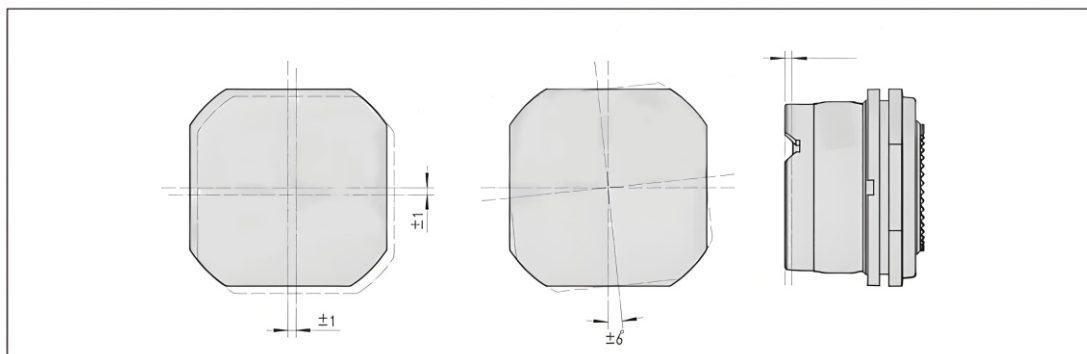

Model Nomenclature

Series Main Name	JYF	27467	T	25	B	42	P	N
Type	27467 - Nut-locking Plug 27999 - Square Plate Plug 27466 - Wall-mounted Square Plate Front-mounted Socket 27496 - Box-mounted Square Plate Front-mounted Socket 27468 - Nut-locking Socket							
Shell Type	T - With Thread at Tail E - Without Thread at Tail							
Shell Number	11/13/15/17/19/21/23/25							
Shell Plating	B - Cadmium-plated Olive Drab F - Chemical Nickel Plating							
Contact Arrangement	(According to GJB599 Series I)							
Contact Type	P - Pin S - Socket							
Key Position	N - Only Normal Key Position							

GJB599 Series I Cabinet-Type Floating (JYF) Electrical Connector

GJB599 Series I Cabinet-Type Floating (JYF) Electrical Connector

Product Introduction

[Environmental Performance]

- Temperature Range:
 - Cadmium-plated olive drab: -65°C ~ +175°C
 - Electroless nickel plating: -65°C ~ +200°C
- High Temperature Resistance: 1000 hours
- Relative Humidity: Up to 98% at 40°C
- Liquid Immersion Resistance: Resistant to various fuels, coolants, and solvents
 - Air Leakage Rate: Maximum 16cm³/h under a pressure difference of 2 atmospheres
- Salt Spray Resistance:
 - Cadmium-plated olive drab: 500 hours
 - Electroless nickel plating: 48 hours
- Liquid Immersion Resistance: Resistant to various fuels, coolants, and solvents

[Mechanical Performance]

- Retention Force of Insulator in Shell: 7 atmospheres
- Retention Force of Contact in Insulator:

Contact Specification	22D	20#	16#	12#	8#	4#
Maximum Load (N)	45	67	110	150	150	150

Mating Force and Separating Force

Shell Number	Maximum Mating Force (N)	Minimum Separating Force (N)
11	20×10	12×10
13	30×10	13×10
15	35×10	15×10
17	50×10	16×10
19	55×10	18×10
21	65×10	22×10
23	80×10	27×10
25	102×10	34×10

- Mechanical Life: 500 cycles
- Random Vibration: 10~2000Hz, acceleration peak 28g
- Sine Vibration: 10~2000Hz, acceleration peak 30g
- Shock: 3ms sine wave, acceleration peak 150g

[Electrical Performance]

Contact Rated Current:

Contact Specification	22D	20#	16#	12#	8#	4#
Rated current (A)	5	7.5	13	23	60	100

Contact Resistance:

Contact Specification	22D	20#	16#	12#	8#	4#
Contact resistance (mΩ)	8	4.7	2	1.1	0.6	0.26

Insulation Resistance: At room temperature ≥ 5000MΩ At high temperature ≥ 1000MΩ

Operating Class

Operating Class	Withstand Voltage at Sea Level (Vrms)	Withstand Voltage at 21,000 Meters Altitude (Vrms)	Working Voltage	
			Vrms	Vdc
M	1300	800	400	550
N	1000	600	300	400
I	1800	1000	600	850
II	2300	1000	900	1250

GJB599 Series I Cabinet-Type Floating (JYF) Electrical Connector

External Dimensions

[Nut Fastening Plug JYF27467]

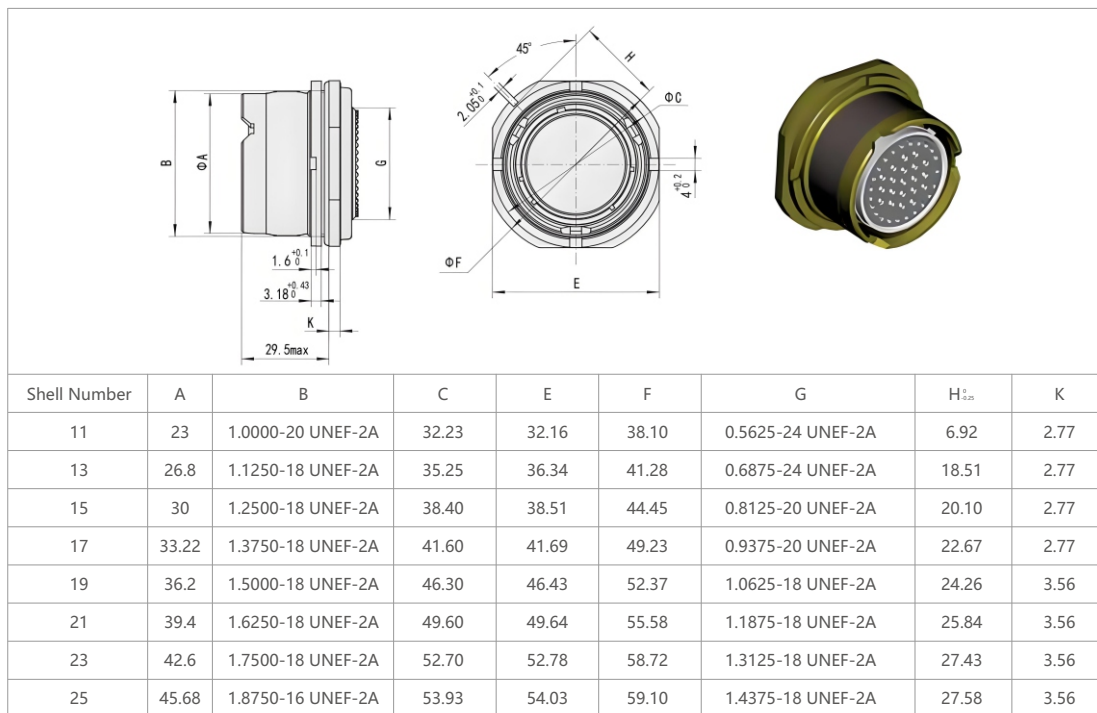

[Nut Fastening Socket JYF27468]

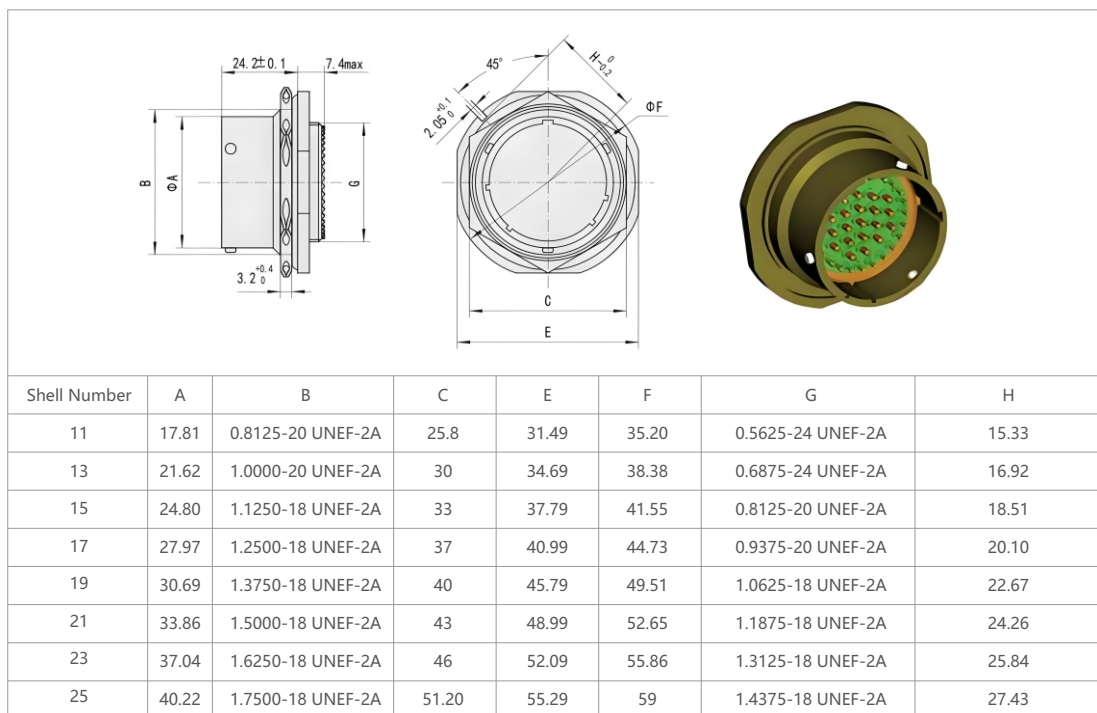

GJB599 Series I Cabinet-Type Floating (JYF) Electrical Connector

[Square Flange Plug JYF27999]

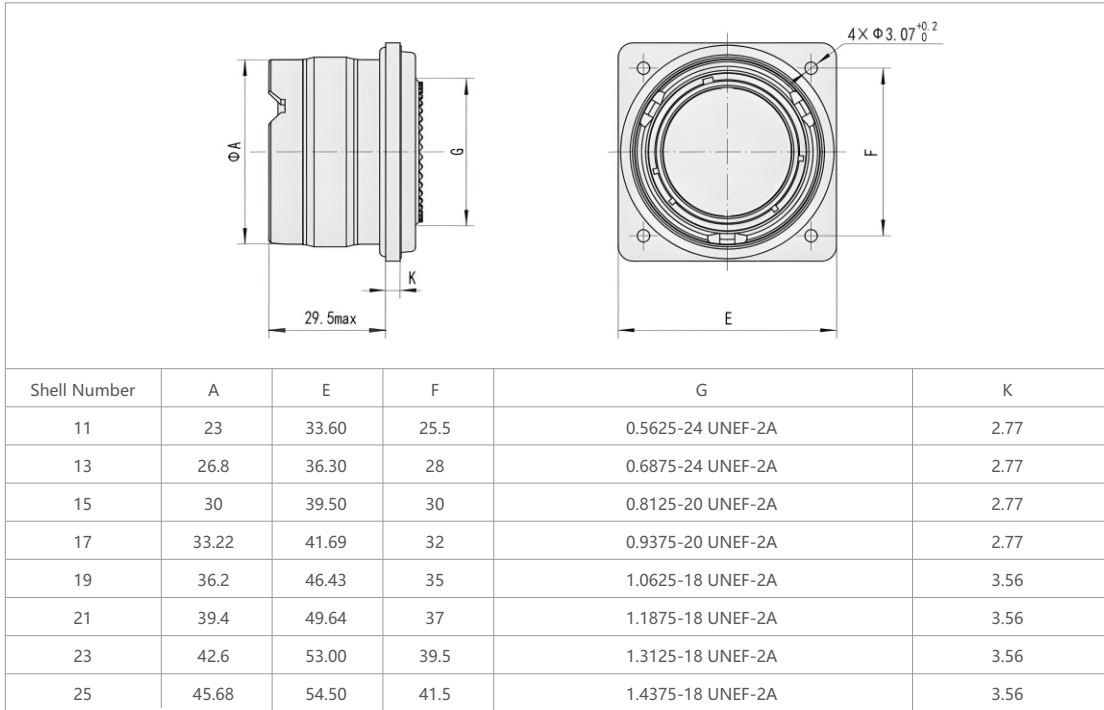

[Wall-Mounted Square Flange Front-Mounted Socket JYF27466]

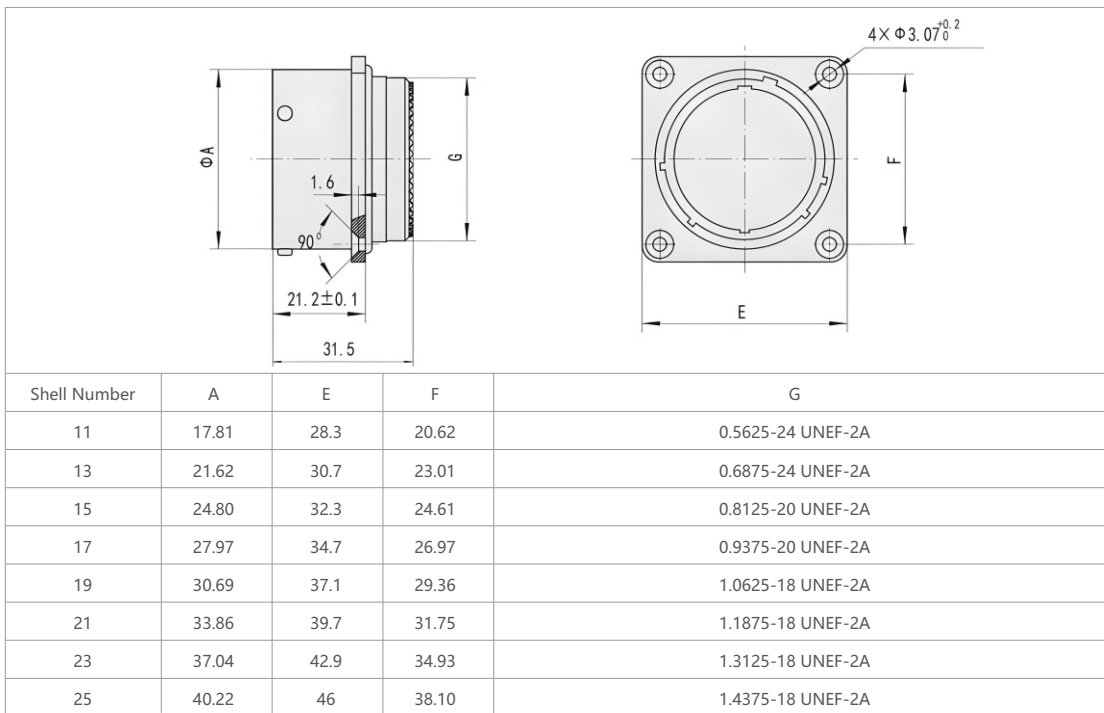

GJB599 Series I Cabinet-Type Floating (JYF) Electrical Connector

[Box-Type Square Flange Front-Mounted Socket JYF27496]

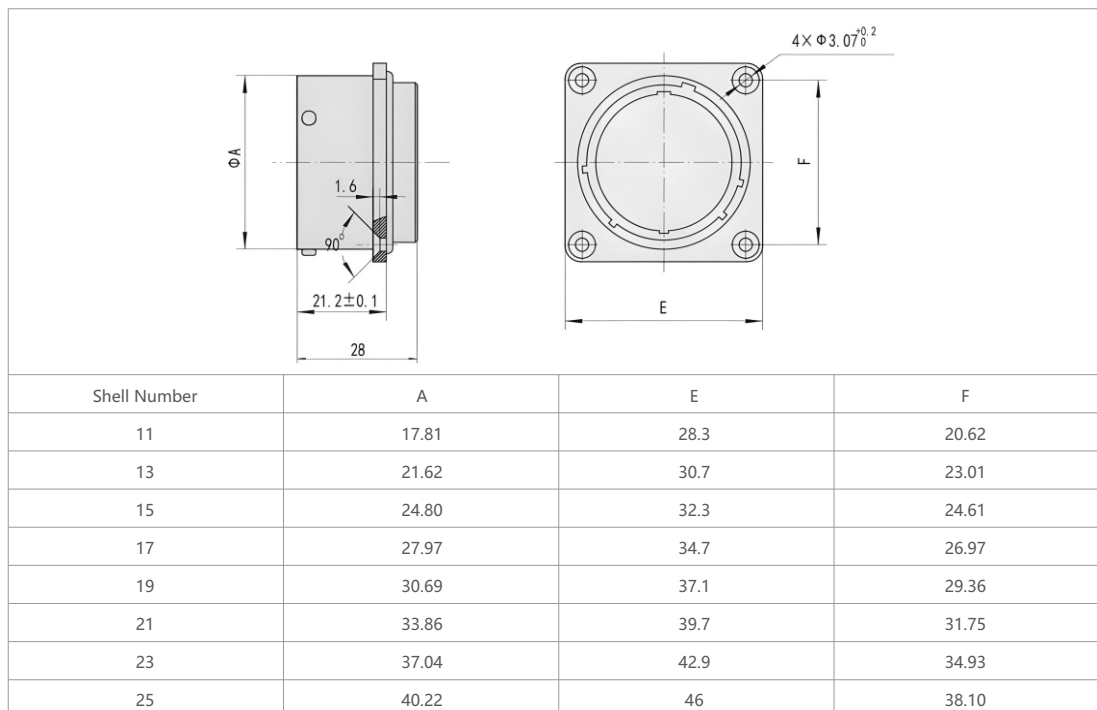

Installation of Connectors

Precautions:

- (1) The dimension between two flanges is a key dimension, which is used to ensure the technical performance after mating.
- (2) The guiding system independent of the connector keeps the moving unit in the correct position.
- (3) The cable must not apply any mechanical pressure to the tail of the plug.

Mated Connector (Nut-Fixed Plug and Nut-Fixed Socket)

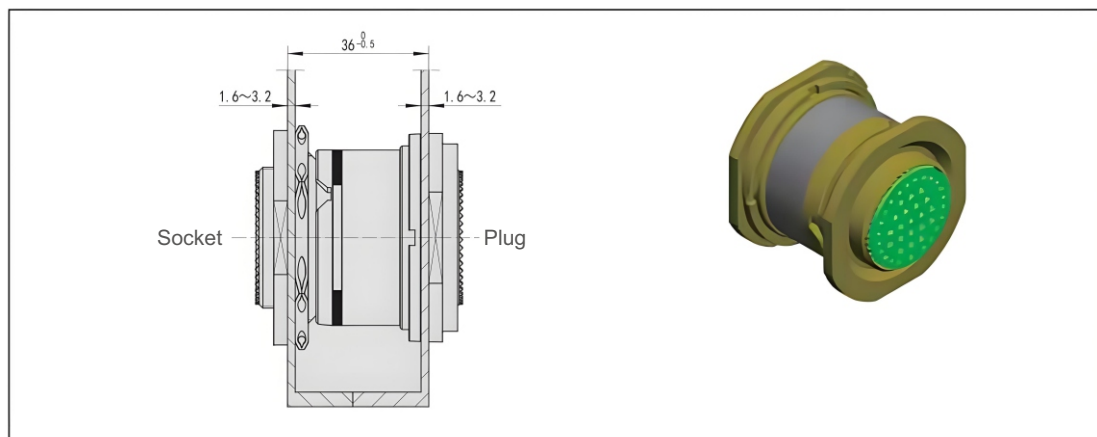

GJB599 Series I Cabinet-Type Floating (JYF) Electrical Connector

[Square Flange Plug JYF27999]

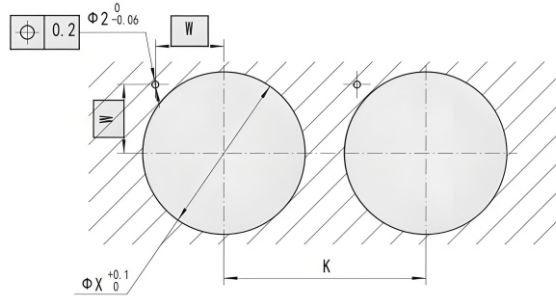

The small hole is used for press-fitting stainless steel dowel pins.

Shell Number	K(min)	H	X _{min}	Nut Connection Torque	
				min	max
Plug					
11	32.60	12.81	32.60	6.2	6.8
13	36	13.94	36	7.9	8.5
15	39.60	15.06	39.60	9	9.6
17	43.30	16.88	43.30	10.2	10.7
19	47	18.00	47	11.3	12.4
21	50.60	19.12	50.60	12.4	13.6
23	54.20	20.24	54.20	13.6	14.7
25	59.70	20.30	59.70	15.8	16.9

Shell Number	K(min)	W	X _{min}	Mated Connector (Square Flange Plug and Square Flange Socket)	
				min	max
Plug					
11	32.60	11.69	32.60	4.5	5.7
13	36	12.81	36	6.2	6.8
15	39.60	13.94	39.60	7.9	8.5
17	43.30	15.06	43.30	9	9.6
19	47	16.88	47	10.2	10.7
21	50.60	18.00	50.60	11.3	12.4
23	54.20	19.12	54.20	12.4	13.6
25	59.70	20.24	59.70	13.6	14.7

Mated Connector (Square Flange Plug and Square Flange Socket)

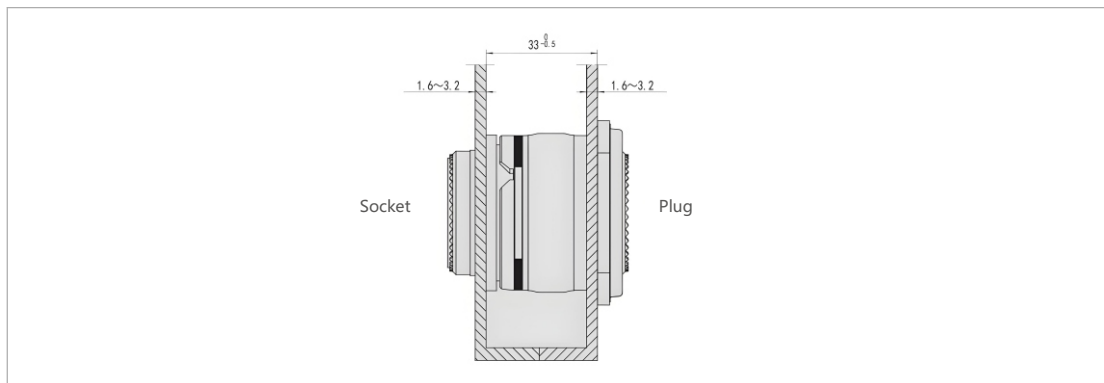

GJB599 Series I Cabinet-Type Floating (JYF) Electrical Connector

Panel Hole Dimensions (Only Applicable to Square Flange Plugs and Square Flange Sockets)

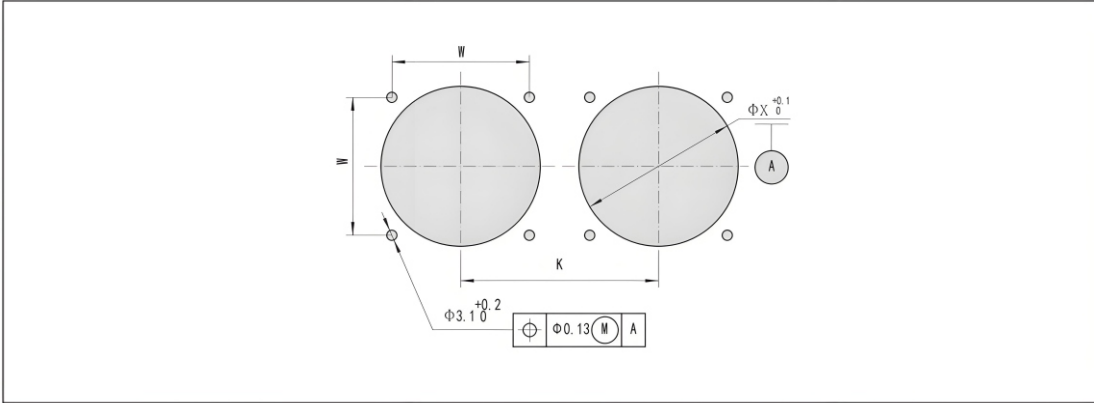

Shell Number	Plug Installation Dimensions		
	$\phi X_{-0}^{+0.1}$	W	K(min)
11	25.58	25.5	36
13	28.80	28	39.6
15	31.98	30	43.3
17	35.15	32	47
19	38.28	35	50.6
21	41.50	37	54.2
23	44.68	39.5	59.7
25	48.08	41.5	59.7

Shell Number	Socket Mounting Dimensions		
	$\phi X_{-0}^{+0.1}$	W	K(min)
11	16.78	20.62	36
13	19.98	23.01	39.6
15	22.88	24.61	43.3
17	25.88	26.97	47
19	29.08	29.36	50.6
21	32.28	31.75	54.2
23	34.08	34.93	59.7
25	37.28	38.1	59.7

GJB599 Series Power Connectors



The pictures are for reference only

GJB599 Series Power Connectors

Product Introduction

- The outline dimensions comply with GJB 599A (MIL-C-38999) Series III.
- It is used for high-power power signal transmission between devices.
- The rated operating current ranges from 7.5A to 185A.
- It features threaded quick connection with an anti-loosening mechanism.
- The tail termination method is crimping or welding.
- Both plugs and sockets can be equipped with pins or holes.



Application

The product is used for high-power power signal transmission between devices.

Operating Environment

The product is suitable for complex environments such as strong vibration, rain, wind and sand, and humidity.

Main Performance

Mechanical Performance

- Housing: Aluminum alloy, stainless steel
- Plating: W - Cadmium-plated olive drab; F - Electroless nickel plating; K - Stainless steel passivation
- Insulator: Thermoplastic material or thermosetting material
- Cable gland and sealing ring: Silicone rubber
- Contact: Copper alloy with gold plating
- Service life: 500 mating cycles
- Shock: 3ms half-sine wave, acceleration peak value 300g
- Vibration: Frequency 100~1000Hz, power spectral density 1g²/Hz, corresponding root mean square 41.7g

Electrical Performance

- Rated voltage, withstand voltage and insulation resistance:

Operating Environment	Rated Voltage V	I	II
Normal Temperature Condition	500	1800	2300
Damp Heat Condition	500	1000	1000

- Housing Conductivity

Type W: 2.5 mΩ

Type F: 1 mΩ

Type K: 5 mΩ

- Shielding

Up to 65dB at 10GHz (F)

Up to 50dB at 10GHz (W)

Up to 85dB at 1GHz (F and W)

Environmental Performance

- Temperature Range:

Type W: -65°C ~ 175°C

Type F: -65°C ~ 200°C

- Sealing: The mated connector meets the low-pressure immersion requirements of MIL-C-38999K

- Contact Resistance of Contacts and Rated Current:

Contact Specification	Contact Resistance mΩ	Rated Current A
20#	≤8.5	7.5
16#	≤4.5	13
12#	≤2.2	23
10#	≤1.2	33
8#	≤0.7	46
6#	≤0.5	60
4#	≤0.35	80
0#	≤0.17	150
2/0#	≤0.124	185

- Salt Spray: According to Method 1001 in GJB 1217, 500 hours (Class W), 1000 hours (Class K), 48 hours (Class F).
- Damp Heat: According to MIL-C-38999K: 24 hours, 10 cycles.
- Liquid Resistance: Resistant to multiple fuels, coolants, and solvents.

GJB599 Series Power Connectors

Model Naming

Series Name	J599/	20	W	G	05	P	N	-H
Type	20-Square Flange Socket 24-Nut Fastened Socket 26-RFI Shielded Plug							
Shell Plating	W – Copper-plated green F – Electroless nickel plating K – Stainless steel passivation							
Shell Number	17	19	21	23	25			
Index Number	E to J	E	F	G	H	J		
Contact Arrangement	See "Contact Arrangement Diagram"							
Contact Type	P – Pin S – Socket							
Keying	N – Normal Keying A, B, C, D, E – Variable Keying							
Weld Contact Identification (Only for Weld Contacts)	H–Weld Contact							

Note:

The tail accessories compatible with this series are the same as those of the "GJB599 III" series. The J1784/38 and J1784/18H bent accessories are not suitable for power series products. It is recommended to use J1784/38H and J1784/18H for longer cables. When there are high temperature and oil resistance requirements, the sealing parts of the connector are made of fluorosilicone rubber. Add "C1" after the original model (e.g.: J599/20FG48PNC1).

[Example of Model Marking]

J599/20KG05PSN-H

J599 series rectangular receptacle, with stainless steel passivation shell plating, G-size shell, 05-position contact, pin contact, N keying, and the solder contact is only suitable for solder connectors.

Crimp Contact

Contact Specification	Working Diameter (mm)	Contact Crimp Barrel		Compatible Wire			Crimp Tensile Strength		Crimp Contact Resistance (mΩ)
		Inner Diameter (mm)	Cross-Sectional Area (mm ²)	AWG Specification	Cross-Sectional Area (mm ²)	Cross-Sectional Diameter	Initial Value (N)	After Thermal Test (N)	
20#	Φ1.0	Φ1.17	Φ1.07	24	0.2047	0.511	30	23	1.0
				22	0.3247	0.643	49	33	0.8
				20	0.5189	0.813	74	62	0.7
16#	Φ1.60	Φ1.68	Φ2.22	20	0.5189	0.813	74	147	0.7
				18	0.8107	1.02	167	184	0.5
				16	1.318	1.29	206	271	0.4
12#	Φ2.40	Φ2.49	Φ4.87	14	2.075	1.63	314	413	0.3
				12	3.332	2.05	471	540	0.2
10#	Φ3.15	3.40	9.07	10	5.26	2.59	601	540	0.1
8#	Φ3.6	4.55	16.25	8	8.37	3.26	881	801	0.05
6#	Φ4.52	5.9	27.3	6	13.3	4.11	1330	1201	0.05
4#	Φ5.72	7.1	39.5	4	21.15	5.19	1780	1601	0.03
0#	Φ9.07	11.48	103.4	0	53.49	8.25	3110	2802	0.02
2/0#	Φ10.31	12.65	125.6	00	67.43	9.27	3340	3003	0.01

Notes:

1. Weld-type contacts are non-removable. Do not install contacts with unwelded wires into the product.
2. Weld-type contacts are packaged separately with the product. After wire welding is completed, install the contacts into the product.
3. When using accessories to press the wires tightly, ensure the contacts are horizontal or have a slight axial movement allowance.
3. The compatible crimping tool for crimp-type contacts is the YTQ manual hydraulic crimping tool.
4. Crimp-type products are equipped with a crimping locator. Before crimping the contacts, put the locator on the wire and then install it into the product together with the contacts.
5. Crimp products are designed with a metal remover and need to be ordered separately.

Crimp Contact Specification	10#	8#	6#	4#	0#	2/0#
Metal Remover Code	JY599-QX-10#	JY599-QX-8#	JY599-QX-6#	JY599-QX-4#	JY599-QX-0#	JY599-QX-2/0#

YTQ Crimp Die	10#	8#	6#	4#
Pin	YTQ-18-Z	YTQ-24-Z YTQ-28-Z	YTQ-30-Z YTQ-32-Z	YTQ-34-Z YTQ-39-Z
Socket	YTQ-18-K	YTQ-24-K YTQ-28-K	YTQ-30-K YTQ-32-K	YTQ-34-K YTQ-39-K

The crimp dies in the table are compatible with YTQ crimping tools and need to be purchased separately.

GJB599 Series Power Connectors

Overall Dimension

Same as GJB599 Series III Electrical Connector

Contact Arrangement (Front View of the Plugging Surface of the Receptacle with Insulator)

17 (E)	62 2-8#				
19 (F)	13 3-10#	01 1-2/0#	02 2-8#		
21 (G)	03 3-8#	04 4-10#	48 4-8#	31 1-0#	05 5-10#
23 (H)	03 3-6#	01 1-2/0#	24 2-4# 2-20#	12 2-6#	
	44 4-10#				
25 (J)	18 8-8#	34 4-9#	14 4-4#	28 4-4# 4-16#	
	22 2-4#	33 3-4#			

Add new contact points as needed.

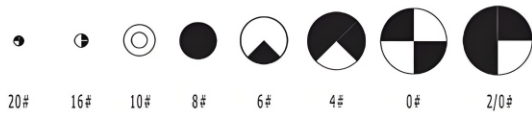

GJB599 Series Power Connectors

Overall Dimensions

[Plug]

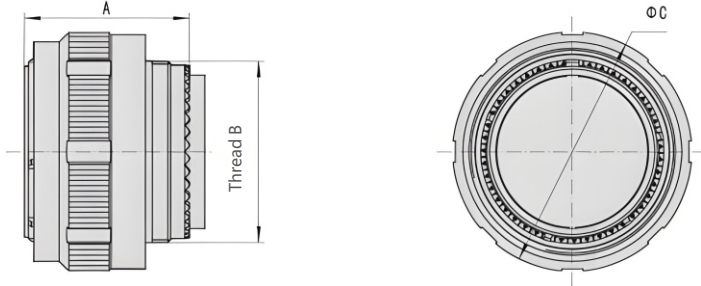

Shell Number	MS Housing Number	A max	Screw Thread B	C max
17	E	31.00	M25×1-6g	35.60
19	F	31.00	M28×1-6g	38.50
21	G	31.00	M31×1-6g	41.70
23	H	31.00	M34×1-6g	44.90
25	J	31.00	M37×1-6g	48.00

[Panel Socket]

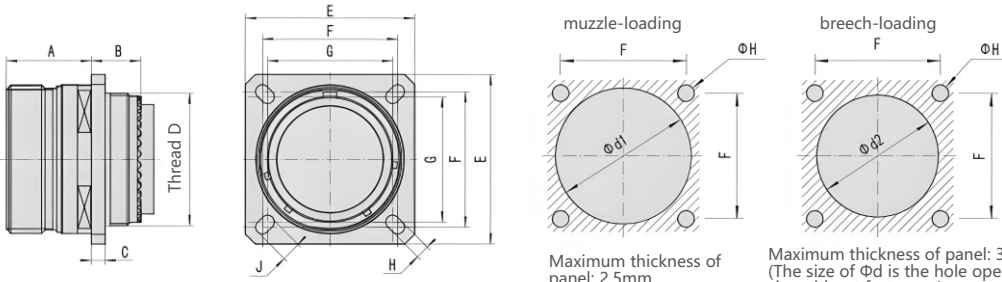

muzzle-loading

breech-loading

Maximum thickness of panel: 2.5mm

Maximum thickness of panel: 3.2mm
(The size of Φd is the hole opening size without fasteners.)

Housing Number	MS Housing Number	A max	B max	C max	Screw Thread D	E	F	G	H	J	d1 min	d2 min
17	E	20.9	10.8	2.5	M25×1-6g	33.3	26.97	24.61	3.25	4.93	30.96	25.81
19	F	20.9	10.8	2.5	M28×1-6g	36.5	29.36	26.97	3.25	4.93	32.94	28.98
21	G	20.1	11.6	3.2	M31×1-6g	39.7	31.75	29.36	3.25	4.93	36.12	32.16
23	H	20.1	11.6	3.2	M34×1-6g	42.9	34.93	31.75	3.91	6.15	39.29	34.93
25	J	20.1	11.6	3.2	M37×1-6g	46.0	38.10	34.93	3.91	6.15	42.47	37.69

GJB599 Series Power Connectors

Nut - Fastened Socket

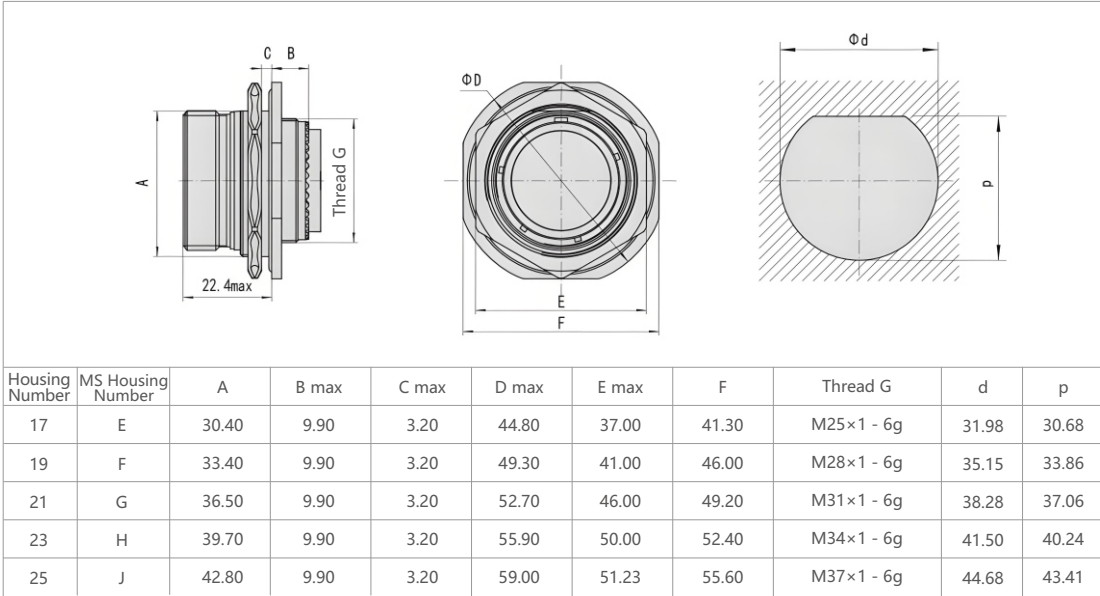

GJB599III Series Power Soldering Connector

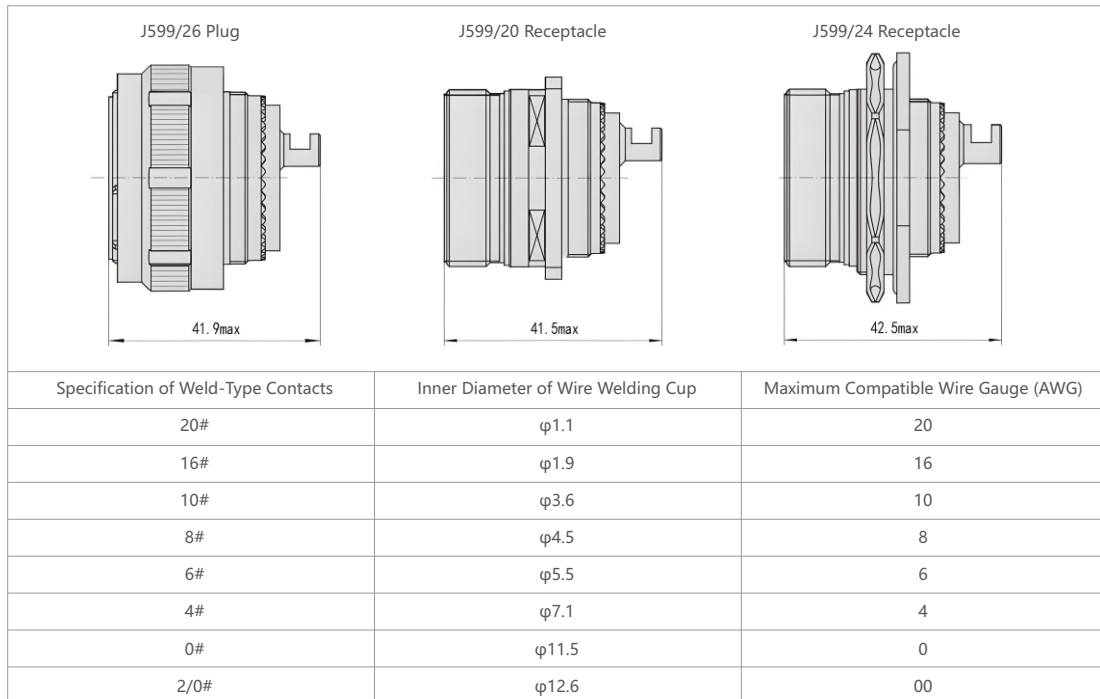

GJB599 Series High-Density Subminiature (JYS) Connector



The pictures are for reference only

GJB599 Series High-Density Subminiature (JYS) Connector

Product Introduction

- High-density subminiature design, light in weight yet high in mechanical strength
- Aluminum alloy
- Suitable for use in extremely small spaces
- Quick bayonet connection
- Contacts are available in crimp, removable, or printed circuit board types
- 2#, 4#, 6# in total three part numbers
- The product complies with the technical specification: Q/21EJ733



Model Naming

Series Name	JYS	0	P	02	05	P	N
Type	0—Oval Flange Mount Receptacle 2—Oval Receptacle with PCB Contacts		1—Cable Termination Receptacle 3—Screw Flange Mount Receptacle		6—Plug		
Shell Material	P: Aluminum Alloy with Hard Gold Plated Nickel						
Shell Number	02—04—06						
Contact Arrangement	See "Contact Arrangement"						
Contact Type	P—Pin SC—Short Printed Circuit Board Socket		S—Socket		PC—Short Printed Circuit Board Pin		
Key Position	N—Normal Key Position; A, B, C, D—Modified Key Positions						

[Model Marking Example]

JYS0P0205PN

JYS series oval flange mount receptacle, shell material is aluminum alloy with hard gold plated nickel, shell number 02, 05 contacts, pin contact, N key position.

Main Performance

Environmental Performance

- Temperature Range: -55°C ~ +175°C
- Relative Humidity: 98%
- Salt Spray Resistance: P Type, 48 Hours
- Liquid Immersion Resistance: Resistant to various fuels, coolants, and solvents

Mechanical Performance

- Mechanical Life: 250 Cycles
- Vibration: 10 - 2000Hz, 1.47m/s²
- Shock: 10 - 2000Hz, 3ms, 300g
- Contact Retention Force: 35N for 26# Contacts, 45N for 22D Contacts

Electrical Performance

Rated Current of Contacts:

Contact	Contact Resistance (mΩ)	Rated Current (A)
26#	15	3
22D	12	5

Insulation Resistance: ≥5000MΩ under normal temperature and pressure

Working Class

Working Class	Sea Level Withstand Voltage (Vrms)
22D Contact	1000
26# Contact	400

Housing Continuity: <60mΩ (Type P)

Crimp Contacts

Contact Specification	Working Diameter (mm)	Inner Diameter of Crimp Sleeve (mm)	Outer Diameter of Crimp Sleeve (mm)	Compatible Wire Cross-Section (mm)	Compatible American Wire Gauge (AWG)	Tooling Code for Removal
26#	Φ0.5	Φ0.45	Φ0.8	0.05 0.08 0.08	30 28 28	M81969/14-01-02
22D	Φ0.76	Φ0.85	Φ1.20	0.125 0.2 0.3	26 24 22	M81969/14-01

GJB599 Series High-Density Subminiature (JYS) Connector

GJB599 Series High-Density Subminiature (JYS) Connector

Structural Dimensions

[Type 6 Plug]

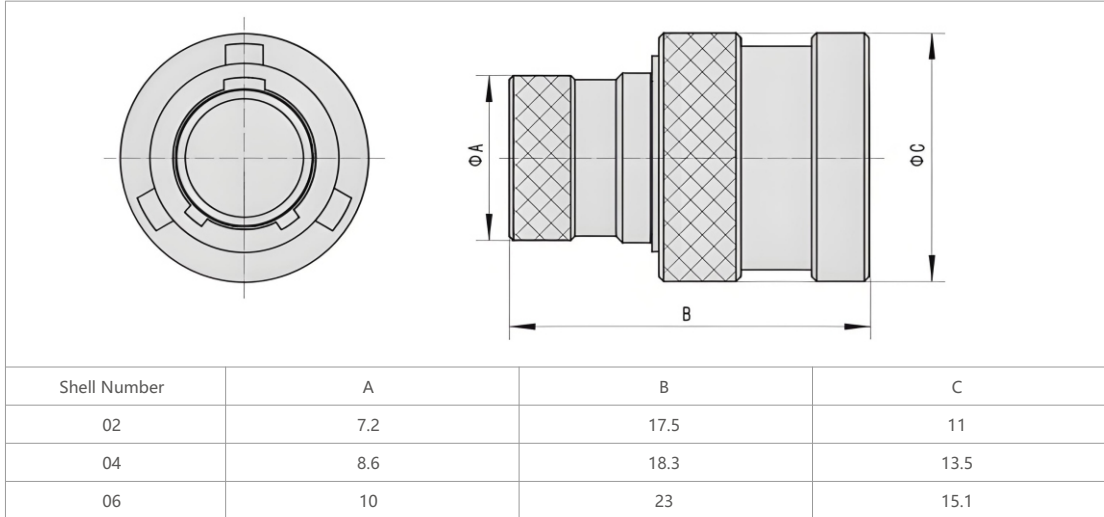

Type O Socket

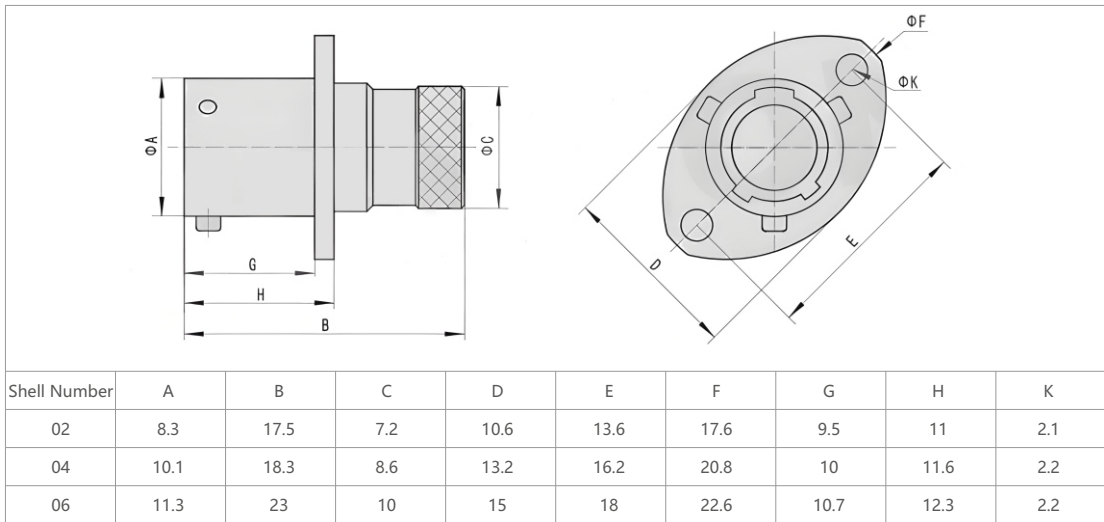

Type 1 Wiring Socket

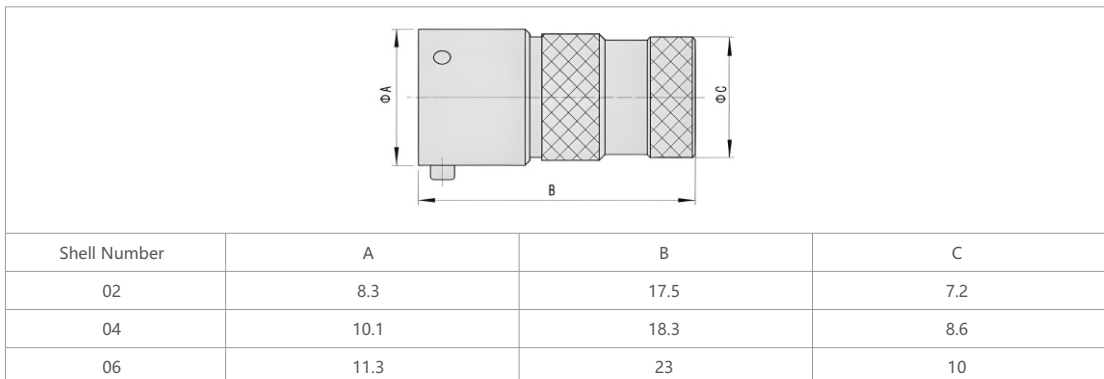

GJB599 Series High-Density Subminiature (JYS) Connector

[Type 2 PCB Board Socket]

The external structural dimensions of the Type 2 PCB Board Socket are the same as those of the Type O Socket.

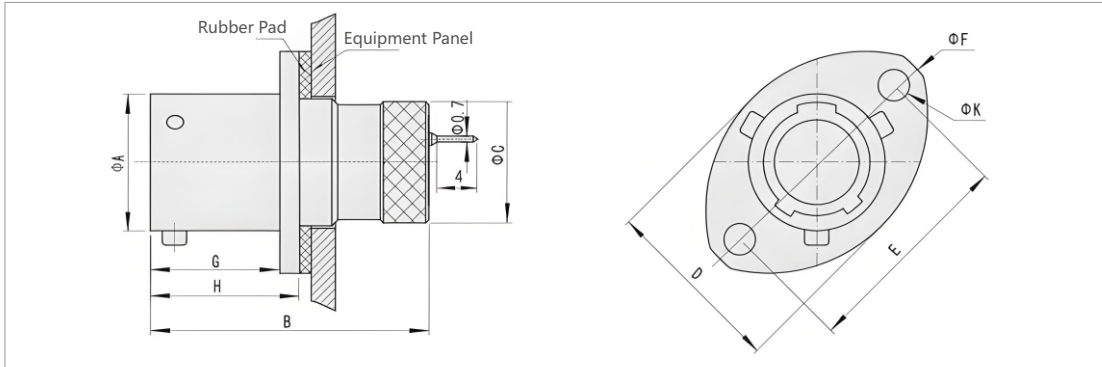

Shell Number	A	B	C	D	E	F	G	H	K
02	8.3	17.5	7.2	10.6	13.6	17.6	9.5	11.2	2.1
04	10.1	18.3	8.6	13.2	16.2	20.8	10	12	2.2
06	11.3	23	10	15	18	22.6	10.7	12.7	2.2

[Type 2 PCB Board Socket]

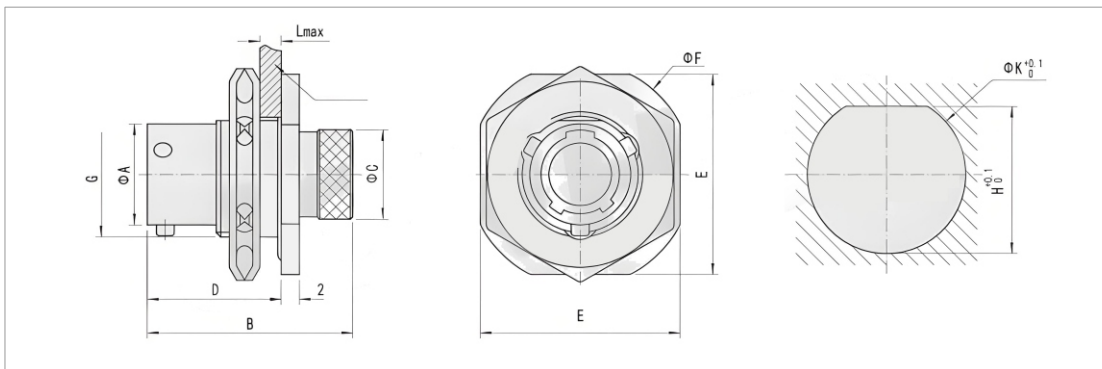

Shell Number	A	B	C	D	E	F	G	L	H	K
02	8.3	17.5	7.2	14	16.4	18	M10×0.75	2.3	9.4	10.2
04	10.1	18.3	8.6	15	20.2	22	M12×1	3	11.5	12.8
06	11.3	23	10	15	22.4	25	M14×1	3	13.2	14.2

[Recommended User Panel Hole Sizing for Type O Socket and Type 2 PCB Board Socket]

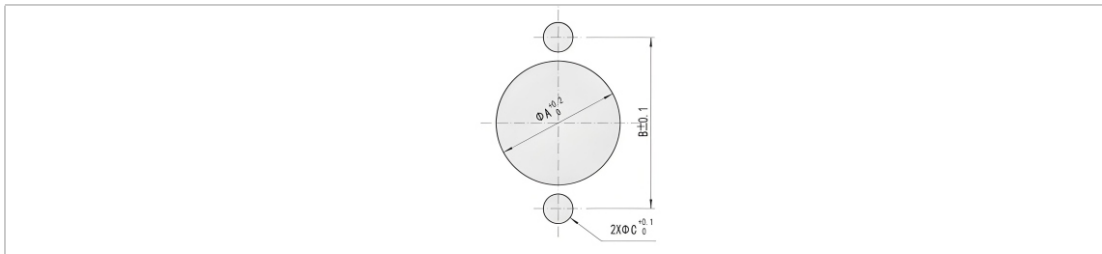

Shell Number	A	B	C
02	7.5	13.6	2.1
04	9	16.2	2.2
06	10.5	18	2.2

GJB599 Series High-Density Subminiature (JYS) Connector

Contact Arrangement

Shell No	Hole Group Arrangement	Number of Contacts	Diagram
02	02-05	5-26#	
02	02-35	3-22D	
04	04-35	3-22D	
06	06-35	5-22D	

GJB599 Series Hermetically Sealed Electrical Connectors

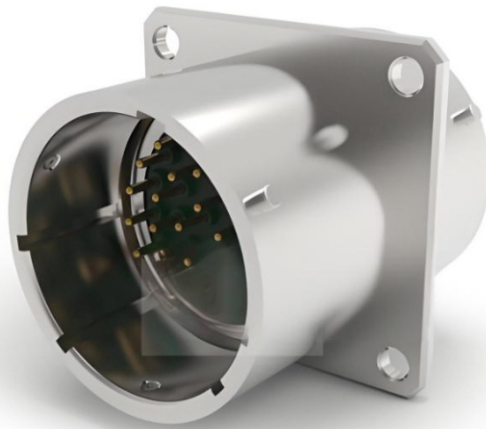

The pictures are for reference only

GJB599 Series Hermetically Sealed Electrical Connectors

GJB599 Series Hermetically Sealed Electrical Connectors

To meet the airtightness requirements of electrical connectors, in accordance with GJB599A (MIL-DTL-38999K) and the corresponding detailed specifications of the U.S. military standard, our company has designed and developed the GJB599 Series I, II, and III hermetic electrical connectors, which are mainly divided into two categories: "sealed electrical connectors" and "wall-penetrating sealed electrical connectors". By sintering the contact parts into the socket shell or the adapter socket shell, the electrical connector has good airtight performance, and the matching plug still uses an ordinary non-sealed plug.

The currently developed GJB599 series sealed sockets and wall-penetrating sealed sockets mainly include:

Socket Type	Installation Method	Basic Marking	Features
GJB599 Series I Sealed Socket	Flange Mounting	JY27469Y-P	Stainless steel shell; bayonet quick connection; Contact parts: soldered pins
	Nut Mounting	JY27470Y-P	
	Soldering Mounting	JY27471Y-P	
GJB599 Series I Wall-Penetrating Sealed Socket	Flange Mounting	JY27466Y-C	Stainless steel shell; bayonet quick connection; Contact parts: wall-penetrating pins
	Nut Mounting	JY27468Y-C	
GJB599 Series II Sealed Socket	Wall-Mounted Flange Mounting (with Thread at the Tail)	JY27475Y-P	Stainless steel short shell; bayonet quick connection; Contact parts: soldered pins
	Box-Mounted Flange Mounting (without Thread at the Tail)	JY27476Y-P	
	Nut Mounting	JY27477Y-P	
	Soldering Mounting	JY27478Y-P	
GJB599 Series III Sealed Socket	Flange Mounting	J599/21Y _n -P	Stainless steel shell; threaded quick connection; Contact parts: soldered pins
	Nut Mounting	J599/23Y _n -P	
	Soldering Mounting	J599/25Y _n -P	
	Fusion Welding Mounting	J599/27Y _n -P	
GJB599 Series III Wall-Penetrating Sealed Socket	Flange Mounting	J599/20Y _n -C	Stainless steel shell; threaded quick connection; Contact parts: wall-penetrating pins
	Nut Mounting	J599/24Y _n -C	

Application

The product is used for circuit signal connection.

Operating Environment

The product is used in complex environments such as strong vibration, rain, sand, and humidity.

Main Performance

[Mechanical Performance]

- Shell: Stainless Steel
- Plating Layer:
 - Series I, II: Type E Stainless Steel Passivation, Type N Electroplated Nickel
 - Series III: Type Y Stainless Steel Passivation, Type N Electroplated Nickel
- Insulator: Fused Glass Material when Equipped with Pins
- Sealing Ring and Interface Seal: Silicone Rubber Material
- Contact: Fe-Ni-Co Sealing Alloy, Nickel-Plated with Gold, Tail Welded

[Electrical Performance]

Withstand Voltage: V

Operating Class*	M	N	I	II
Sea Level	1300	1000	1800	2300
21000m	800	600	1000	1000

Note: Different contact arrangements have different working levels. For details, see Contact Arrangement.

Electromagnetic Interference Shielding:

At 100MHz~1GHz, the minimum attenuation is 85dB

At 1GHz~10GHz, the minimum attenuation is 50dB

[Environmental Performance]

- Temperature Range: -65°C ~ +200°C
- Airtightness: When the pressure difference between the two ends of the sealed socket is 1 atmosphere, the air leakage rate $\leq 1 \times 10^{-3}$ Pa·cm³/s
- Mechanical Life: 500 mating cycles
- Shock: 3ms half-sine wave, acceleration peak value 300g
- Vibration:
 - Series I, III
 - Sinusoidal Vibration: Frequency 10~2000Hz, Acceleration 294m/s²
 - Random Vibration: Frequency 100~1000Hz, Power Spectral Density 1g²/Hz
 - Series II
 - Random Vibration: Frequency 100~1000Hz, Power Spectral Density 0.4g²/Hz
- Contact Resistance and Rated Current of Contacts:

Contact Specifications	Working Diameter (mm)	Contact Resistance (mΩ)	Rated Current (A)
22D	Φ0.76	≤28	5
20#	Φ1.00	≤12	7.5
16#	Φ1.60	≤8.5	13
12#	Φ2.40	≤5.0	23

Insulation Resistance: ≥5000MΩ under normal conditions

GJB599 Series Hermetically Sealed Electrical Connectors

Model Naming

[GJB599 Series I]

Series Main Name	JYF	27469	Y	17	N	35	P	N
Type	27469 – Flange Mounted Sealed Socket 27470 – Nut Mounted Sealed Socket 27471 – Soldered Mounted Sealed Socket (Only N Plating Optional) 27466 – Wall-Mounted Flange Through-Wall Sealed Socket 27468 – Nut Mounted Through-Wall Sealed Socket							
Shell Type	Y – Hermetic Seal Type							
Shell Number	09 – 11 – 13 – 15 – 17 – 19 – 21 – 23 – 25							
Shell Plating	E – Stainless Steel Passivation N – Electroplated Nickel							
Contact Arrangement	See “Contact Arrangement” Diagram							
Contact Type	For Sealed Sockets: P – Pin (Only Pin-Mounting Type) For Through-Wall Sealed Sockets: C – Through-Wall Pin Contact							
Key Position	N – Normal Key Position; A, B, C, D – Variable Key Positions							

Note:

In the model naming of the national military standard GJB599A and the U.S. military standard MIL-DTL-38999K, except for the different main designators, the rest are completely the same. The main designator of GJB599A is “JY”, and that of MIL-DTL-38999K is “MS”. They are interchangeable and intermateable.

The two plugs mated with the through-wall sealed socket must both be hole-mounted, one is a left plug and the other is a right plug.

The left plug should be marked with “-U” after the original plug model, and the right plug is marked with the original plug model.

[Model Marking Example]

JY27469Y17E35PNIt is a JY series flange-mounted sealed socket, hermetic seal type, housing number 17, housing plating is stainless steel passivation, contact arrangement 35, contact is pin, key position N.

[GJB599 Series II]

Series Main Name	JY	27475	Y	16	N	35	P	N
Type	27475 – Wall-Mounted Flange Sealed Socket 27476 – Box-Mounted Flange Sealed Socket 27477 – Nut-Mounted Sealed Socket 27478 – Soldered Mounted Sealed Socket (Only N Plating Optional)							
Shell Type	Y – Hermetic Seal Type							
Shell Number	08 – 10 – 12 – 14 – 16 – 18 – 20 – 22 – 24							
Shell Plating	E – Stainless Steel Passivation N – Electroplated Nickel							
Contact Arrangement	See “Contact Arrangement” Diagram							
Contact Type	P – Pin							
Key Position	N – Normal Key Position; A, B, C, D – Variable Key Positions							

Note: The model naming of the national military standard GJB599A and the U.S. military standard MIL-DTL-38999K are identical except for the main designator. The main designator of GJB599A is “JY”, and that of MIL-DTL-38999K is “MS”. They are interchangeable and intermateable.

[Model Marking Example]

JY27475Y16E35PNIt is a JY series wall-mounted flange sealed socket, hermetic seal type, housing number 16, housing plating is stainless steel passivation, contact arrangement 35, contact is pin, key position N.

GJB599 Series Hermetically Sealed Electrical Connectors

[GJB599 Series III]

Series Main Name	J599/	21	Y	E	35	P	N
Type	21 – Flange Mounted Sealed Socket 23 – Nut Mounted Sealed Socket 25 – Soldered Mounted Sealed Socket (Only N Plating Optional) 27 – Fusion Welded Mounted Sealed Socket 20 – Flange Mounted Through-Wall Sealed Socket 24 – Nut Mounted Through-Wall Sealed Socket						
Shell Plating	Y – Stainless Steel Passivation N – Stainless Steel Electroplated Nickel						
Shell Number Shell Code	See “Contact Arrangement” Diagram						
Contact Arrangement	09 11 13 15 17 19 21 23 25 A to J $\frac{A}{A}$ $\frac{B}{B}$ $\frac{C}{C}$ $\frac{D}{D}$ $\frac{E}{E}$ $\frac{F}{F}$ $\frac{G}{G}$ $\frac{H}{H}$ $\frac{J}{J}$						
Contacts	For Sealed Sockets: P – Pin (Only Pin-Mounting Type) For Through-Wall Sealed Sockets: C – Through-Wall Pin Contact						
Key Position	N – Normal Key Position; A, B, C, D, E – Variable Key Positions						

Note:

1. In the model naming of the national military standard GJB599A and the U.S. military standard MIL-DTL-38999K, except for the different main designators, the rest are identical. The main designator of GJB599A is "J599", and that of MIL-DTL-38999K is "D38999". They are interchangeable and intermateable.
2. The two plugs mated with the through-wall sealed socket must both be hole-mounted, one is a left plug and the other is a right plug. The left plug should be marked with "-U" after the original plug model, and the right plug is marked with the original plug model.

[Model Marking Example]

J599/21YE35PNIt is a J599 series flange-mounted sealed socket, with stainless steel passivation for the housing plating, housing code E, contact arrangement 35, pin contacts, and key position N.

Overall Dimensions

GJB599 Series I Sealed Socket

[JY27469 Wall-Mounted Sealed Socket]

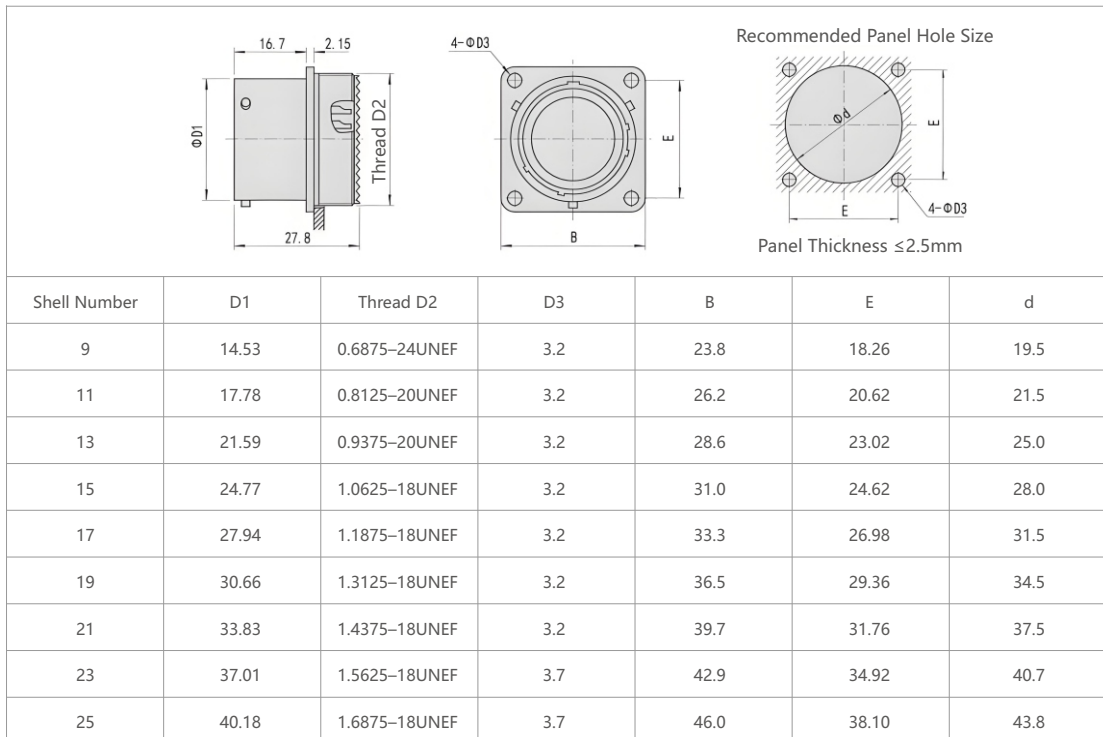

GJB599 Series Hermetically Sealed Electrical Connectors

[JY27470 Nut Mounted Sealed Receptacle]

Shell Number	D1	D2	D3	D4	L	K	B	d	p
9	14.53	15.29	16.31	30.18	29.9	2.8	26.97	17.7	17.0
11	17.78	18.44	19.46	34.93	29.9	2.8	31.75	21.0	19.6
13	21.59	21.64	22.66	38.10	29.9	2.8	34.93	25.6	24.3
15	24.77	24.84	25.86	41.28	29.9	2.8	38.10	28.8	27.6
17	27.94	27.99	29.01	44.45	29.9	2.8	41.28	32.0	30.7
19	30.66	31.19	32.21	49.23	30.7	3.6	46.02	35.2	33.9
21	33.83	34.34	35.36	52.37	30.7	3.6	49.23	38.3	37.1
23	37.01	37.54	38.56	55.58	30.7	3.6	52.37	41.5	40.0
25	40.18	40.69	41.7	58.72	30.7	3.6	55.58	44.7	43.4

[JY27471 Soldering Mounted Sealed Receptacle]

Shell Number	D1	D2	D3	d	L1max		L2		L3	
					Pin	Hole	Pin	Hole	Pin	Hole
9	14.53	17.07	19.05	17.6	9.6	10.09	16.7	18.97	22.3	25
11	17.78	19.84	21.44	20.3	9.6	10.09	16.7	18.97	22.3	25
13	21.59	23.01	24.61	23.5	9.6	10.09	16.7	18.97	22.3	25
15	24.77	26.19	27.79	26.7	9.6	10.09	16.7	18.97	22.3	25
17	27.94	29.36	30.94	29.9	9.6	10.09	16.7	18.97	22.3	25
19	30.66	31.75	33.32	32.3	9.6	10.09	16.7	18.97	22.3	25
21	33.83	34.93	36.53	35.4	9.6	10.09	16.7	18.97	22.3	25
23	37.01	38.10	39.70	38.6	9.6	10.85	16.7	18.97	23.1	25.8
25	40.18	41.28	42.88	41.8	9.6	9.55	16.7	18.97	23.1	25.8

GJB599 Series Hermetically Sealed Electrical Connectors

GJB599 Series I Wall-Penetrating Sealed Socket

[JY27466 Wall-Mounted Square Flange Installation Wall-Penetrating Sealed Socket]

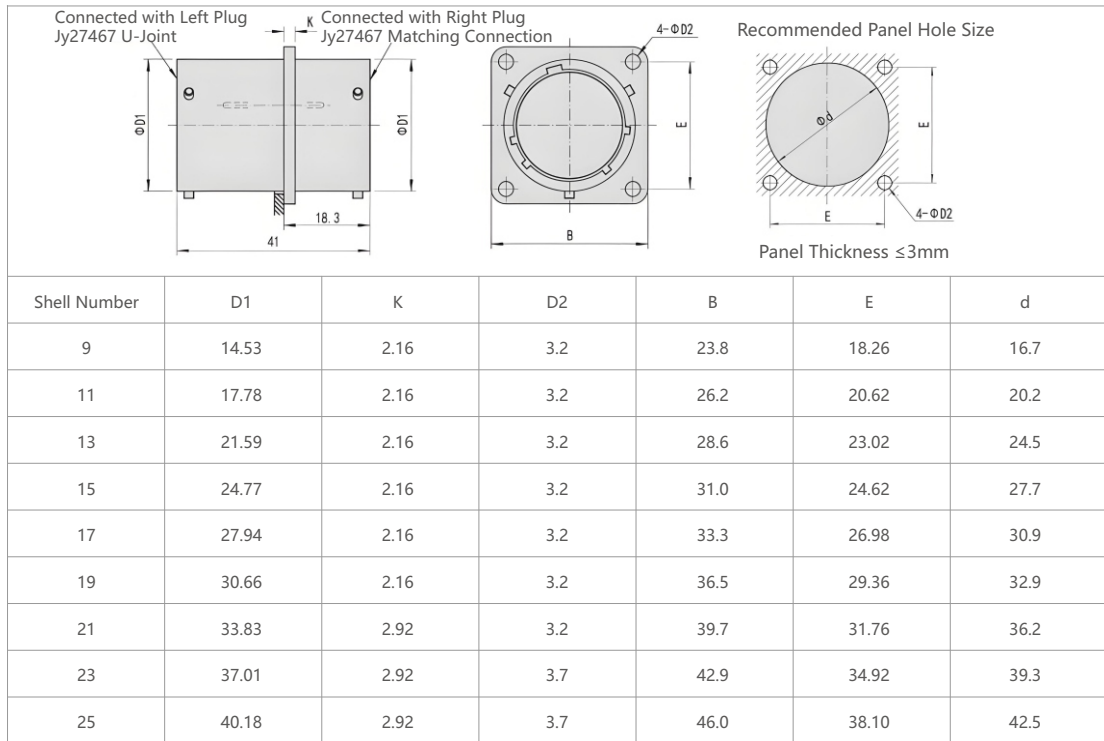

[JY27468 Nut-Mounted Wall-Penetrating Sealed Socket]

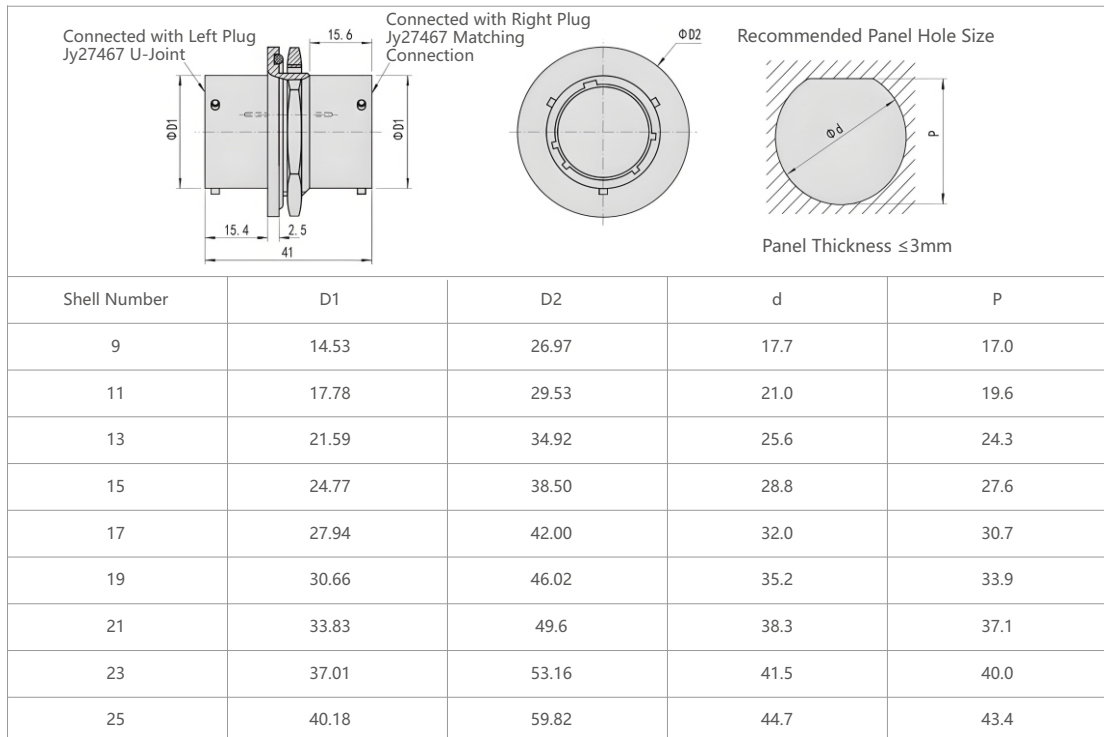

GJB599 Series Hermetically Sealed Electrical Connectors

GJB599 Series II Sealed Socket

[JY27475 Wall-Mounted Sealed Socket]

Shell Number	D1	Thread D2	L	D3	B	E	d
8	12.00	0.5625-24UNEF	15.9	3.2	21.0	15.09	15.5
10	15.00	0.6875-24UNEF	15.9	3.2	24.1	18.26	19.5
12	19.05	0.8125-20UNEF	15.9	3.2	26.5	20.62	21.5
14	22.23	0.9375-20UNEF	15.9	3.2	28.9	23.01	25.0
16	25.40	1.0625-18UNEF	15.9	3.2	31.2	24.61	28.0
18	28.58	1.1875-18UNEF	15.9	3.2	33.6	26.97	31.5
20	31.75	1.3125-18UNEF	15.9	3.2	36.8	29.36	34.5
22	34.93	1.4375-18UNEF	19.1	3.2	40.0	31.75	37.5
24	38.10	1.5625-18UNEF	19.1	4.0	43.1	34.93	40.7

Note: When using accessories, the housing number of the corresponding accessory should be two housing numbers larger than that of the socket.

[JY27476 Box-Mounted Sealed Socket]

Shell Number	D1	D2	L	D3	B	E	d
8	12.00	14.27	11.5	3.2	21.0	15.09	15.3
10	15.00	17.07	11.5	3.2	24.1	18.26	18.1
12	19.05	19.84	11.5	3.2	26.5	20.62	20.8
14	22.23	23.01	11.5	3.2	28.9	23.01	24.0
16	25.40	26.19	11.5	3.2	31.2	24.61	27.2
18	28.58	29.36	11.5	3.2	33.6	26.97	30.4
20	31.75	31.75	11.5	3.2	36.8	29.36	32.8
22	34.93	34.93	12.3	3.2	40.0	31.75	35.9
24	38.10	38.10	12.3	4.0	43.1	34.93	39.1

GJB599 Series Hermetically Sealed Electrical Connectors

[JY27477 Nut-Mounted Sealed Socket]

Shell Number	D1	D2	L	B	d	p
8	12.00	34.95	13.5	31.75	22.46	21.08
10	15.00	38.10	13.5	34.95	25.58	24.26
12	19.05	41.28	13.5	38.10	28.80	27.53
14	22.23	44.45	13.5	41.28	31.98	30.68
16	25.40	49.23	13.5	45.24	35.15	33.86
18	28.58	51.21	13.5	48.00	38.28	37.06
20	31.75	54.38	14.2	51.21	41.50	40.03
22	34.93	57.53	14.2	54.36	44.68	43.21
24	38.10	60.71	14.2	57.53	47.85	46.38

[JY27478 Soldering-Mounted Sealed Socket]

Shell Number	D1	D2	D3	L	d
8	12.00	14.27	17.45	12.0	14.8
10	15.00	17.07	20.24	12.0	17.6
12	19.05	19.84	23.01	12.0	20.3
14	22.23	23.01	26.19	12.0	23.5
16	25.40	26.19	29.36	12.0	26.7
18	28.58	29.36	32.54	12.0	29.9
20	31.75	31.75	34.93	12.0	32.3
22	34.93	34.93	38.10	12.8	35.4
24	38.10	38.10	41.28	12.8	38.6

GJB599 Series Hermetically Sealed Electrical Connectors

GJB599 Series III Sealed Socket

[J599/21 Square Flange Mounted Sealed Socket]

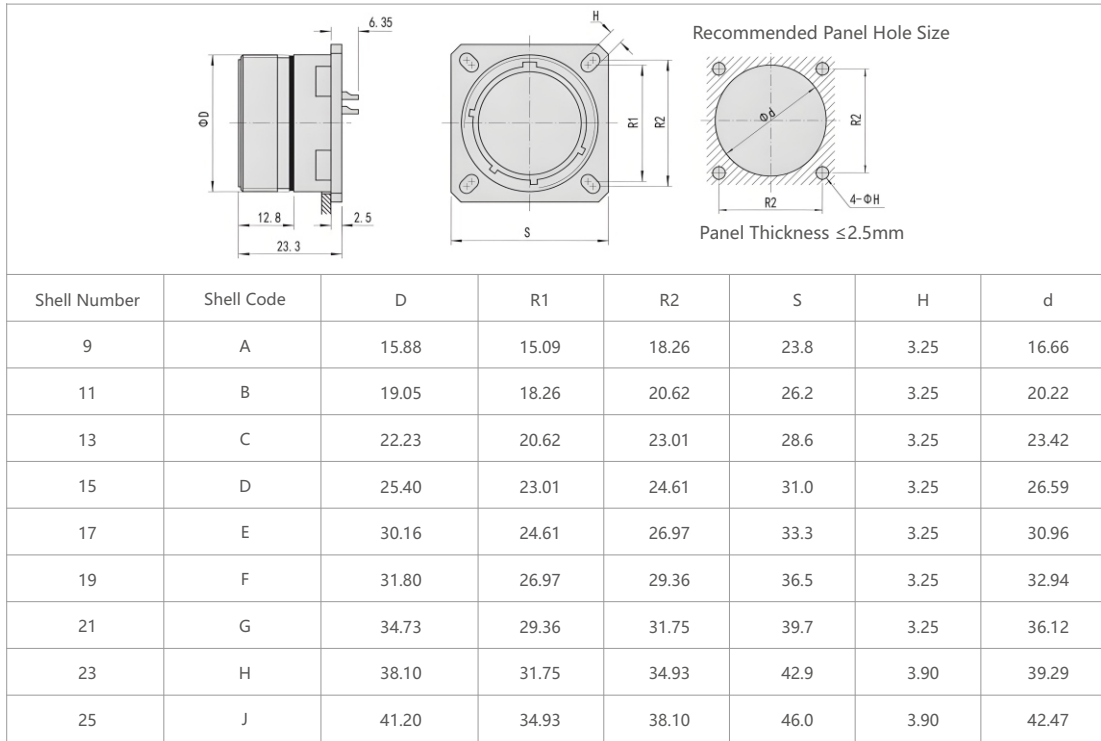

[J599/23 Nut-Mounted Sealed Socket]

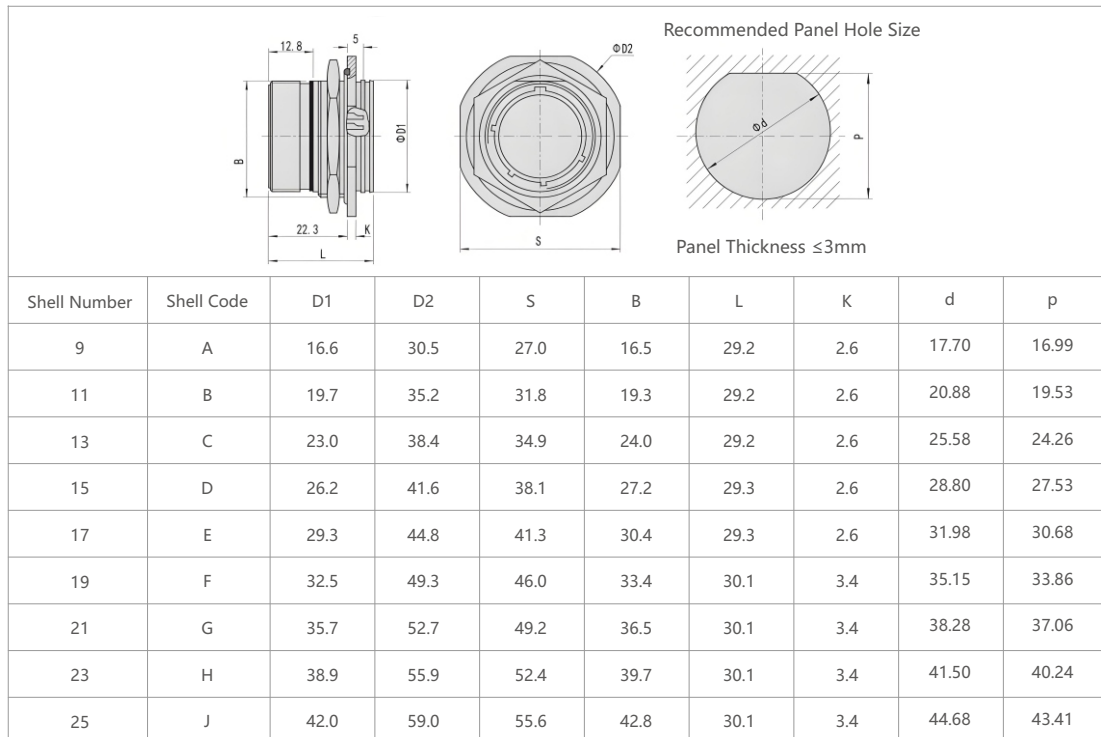

GJB599 Series Hermetically Sealed Electrical Connectors

[J599/25 Soldering-Mounted Sealed Socket]

Shell Number	Shell Code	D1	D2	L	d
9	A	17.1	19.4	23.8	17.6
11	B	19.9	21.8	23.8	20.4
13	C	23.1	24.9	23.8	23.6
15	D	26.2	28.1	23.8	26.7
17	E	29.4	31.3	23.8	29.9
19	F	31.8	33.6	23.8	32.3
21	G	35.0	36.8	23.8	35.5
23	H	38.2	40.0	24.6	38.7
25	J	41.3	43.2	24.6	41.8

[J599/27 Fusion Welding-Mounted Sealed Socket]

Shell Number	Shell Code	D1	D2	L	K
9	A	15.88	25.0	24.1	3.2
11	B	19.05	28.1	24.1	3.2
13	C	22.23	31.3	24.1	3.2
15	D	25.40	34.5	24.1	3.2
17	E	30.16	36.7	24.1	3.2
19	F	31.80	40.4	24.1	3.2
21	G	34.73	44.0	24.1	3.2
23	H	38.10	48.2	24.9	4.0
25	J	41.20	50.4	24.9	4.0

GJB599 Series Hermetically Sealed Electrical Connectors

GJB599 Series III Wall-Penetrating Sealed Socket

[J599/20 Square Panel-Mounted Wall-Penetrating Sealed Socket]

Shell Number	Shell Code	D1	A	K	R1	R2	S	H	d
9	A	15.88	19.5	2.1	15.09	18.26	23.8	3.25	16.66
11	B	19.05	19.5	2.1	18.26	20.62	26.2	3.25	20.22
13	C	22.23	19.5	2.1	20.62	23.01	28.6	3.25	23.42
15	D	25.40	19.5	2.1	23.01	24.61	31.0	3.25	26.59
17	E	30.16	19.5	2.1	24.61	26.97	33.3	3.25	30.96
19	F	31.80	19.5	2.1	26.97	29.36	36.5	3.25	32.94
21	G	34.73	18.7	2.8	29.36	31.75	39.7	3.25	36.12
23	H	38.10	18.7	2.8	31.75	34.93	42.9	3.90	39.29
25	J	41.20	18.7	2.8	34.93	38.10	46.0	3.90	42.47

[J599/24 Nut-Mounted Wall-Penetrating Sealed Socket]

Shell Number	Shell Code	D	S	H	Thread V	d	p
9	A	30.5	27.0	16.5	0.6875-24UNEF	17.70	16.99
11	B	35.2	31.8	19.3	0.8125-20UNEF	20.88	19.53
13	C	38.4	34.9	24.0	1.0000-20UNEF	25.58	24.26
15	D	41.6	38.1	27.2	1.1250-18UNEF	28.80	27.53
17	E	44.8	41.3	30.4	1.2500-18UNEF	31.98	30.68
19	F	49.3	46.0	33.4	1.3750-18UNEF	35.15	33.86
21	G	52.7	49.2	36.5	1.5000-18UNEF	38.28	37.06
23	H	55.9	52.4	39.7	1.6250-18UNEF	41.50	40.24
25	J	59.0	55.6	42.8	1.7500-20UN	44.68	43.41

GJB599 Series Hermetically Sealed Electrical Connectors

[JY27468Y-C8 Series Wall-Penetrating Sealed Socket (8mm Panel Thickness Type)]

Series Main Name	JY 27468 Y 17 E 35 C 8 N -S
Type	27468—Nut-Mounted Wall-Penetrating Sealed Socket
Shell Category	Y—Hermetic Seal Type
Shell Number	09-11-13-15-17-19-21-23-25
Shell Plating	E—Stainless Steel Passivation; N—Stainless Steel Electroplated Nickel; TA—Titanium Alloy
Contact Arrangement	See "GJB599I Series Contact Arrangement Diagram"
Contact Type	C—Wall-Mounted Pin Contact
Maximum Panel Thickness	8
Key Position	N—Standard Key Position; A, B, C, D—Alternate Key Positions
Safety Hole Marking	—S

Notes:

1. Both plugs mated with the wall-penetrating sealed socket must be socket-type (receptacle) — one left plug and one right plug. For the left plug, add "-U" after the original plug model; the right plug uses the original plug model as marked.
2. The left plug end is located inside the cabin, and the right plug end is located outside the cabin.
3. When the product is a socket with a safety hole, add "-S" at the end of the model. Example: JY27468Y17E35C8N-S.

[Overall Dimensions]

Left Plug Mating Mated with JY27467-JU

Right Plug Mating Mated with Jy27467

Recommended Panel Hole Size

Panel Thickness ≤8mm

Shell Number	A		B		D1	D2		D3	d	p	R
	Without -S	With -S	Without -S	With -S		With -S	Without -S				
9	15.4	14.8	2.5	4	14.56	30.97	27.97	18.5	18.7	18.0	≤6
11	15.4	14.8	2.5	4	17.81	33.53	30.53	21.6	22.0	20.6	
13	15.4	14.8	2.5	4	21.59	38.92	35.92	26.4	26.6	25.3	
15	15.4	14.8	2.5	4	24.77	42.50	39.50	29.6	29.8	28.6	
17	15.4	14.8	2.5	4	27.97	46.00	43.00	32.8	33.0	31.7	
19	15.4	14.8	2.5	4	30.69	50.02	47.02	36	36.2	34.9	≤8
21	15.4	14.8	2.5	4	33.83	53.60	50.60	39.1	39.3	38.1	
23	15.4	14.8	2.5	4	37.00	57.16	54.16	42.3	42.5	41.0	
25	15.4	14.8	2.5	4	40.20	63.82	60.82	45.5	45.7	44.4	

[Installation Diagram]

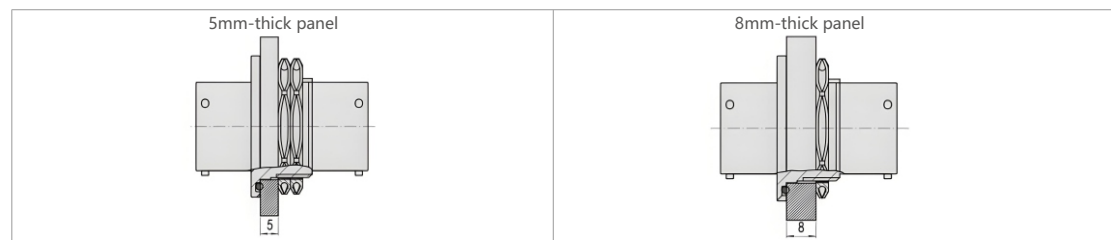

Notes:

1. Each wall-penetrating socket is equipped with two locking nuts; the usage (of one or two nuts) depends on the specific thickness of the panel.
2. When the panel thickness is 8mm, it is recommended to use one locking nut and apply safety locking (e.g., safety wire) at the same time.

GJB599 Series Hermetically Sealed Electrical Connectors

[J599/24Y - C8 Panel Thickness 8mm Type Nut - Mounted Through - Wall Sealed Socket]

Series Name	J599/ 24 Y B 35 C 8 N S
Type	24—Nut-Locking Socket
Shell Plating	Y—Stainless Steel Passivation; N—Stainless Steel Electroplated Nickel; TA—Titanium Alloy
Shell Number Index Number	09 11 13 15 17 19 21 23 25 A to J A B C D E F G H J
Contact Arrangement	See "GJB599III Series Contact Arrangement Diagram"
Contact Type	C—Wall-Mounted Pin Contact
Maximum Panel Thickness	8
Key Position	N—Standard Key Position; A, B, C, D, E—Alternate Key Positions
Safety Hole Marking	—S

- Notes: 1.Both plugs mated with the wall-penetrating sealed socket must be socket-type (receptacle): one left plug and one right plug. For the left plug, add "-U" after the original plug model; the right plug uses the original plug model as marked.
 2.The left plug end is located inside the cabin, and the right plug end is located outside the cabin.
 3.The above model naming rules apply only to low-frequency products; they are not applicable to products equipped with coaxial, differential, or other special contacts. For detailed models and technical parameters, please consult specifically.
 4.When the product is a socket with a safety hole, add "-S" at the end of the model. Example: J599/24YB35C8N-S.

[Overall Dimensions]

Shell Code	D1	D2	S	H	Thread V	d	p	R
A	18.5	31.5	28.0	17.5	0.6875-24UNEF	18.70	17.99	≤6
B	21.6	36.2	32.8	20.3	0.8125-20UNEF	21.88	20.53	
C	26.4	39.4	35.9	25.0	1.0000-20UNEF	26.58	25.26	≤6
D	29.6	42.6	39.1	28.2	1.1250-18UNEF	29.80	28.53	
E	32.8	45.8	42.3	31.4	1.2500-18UNEF	32.98	31.68	≤8
F	35.9	50.3	47.0	34.4	1.3750-18UNEF	36.15	34.86	
G	39.1	53.7	50.2	37.5	1.5000-18UNEF	39.28	38.06	
H	42.3	56.9	53.4	40.7	1.6250-18UNEF	42.50	41.24	
J	45.5	60.0	56.6	43.8	1.7500-20UN	45.68	44.41	≤10

[Installation Diagram]

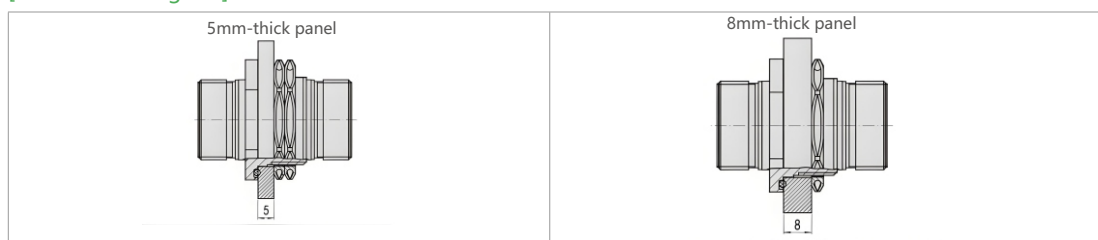

- Notes:
 1.Each wall-penetrating socket is equipped with two locking nuts; the usage (of one or two nuts) depends on the specific thickness of the panel.
 2.When the panel thickness is 8mm, it is recommended to use one locking nut and apply safety locking (e.g., safety wire) at the same time.

GJB599 Series Hermetically Sealed Electrical Connectors

GJB599 Series Hermetic Sealing Connector Contact Arrangement
(View of Pin-Equipped Insulator Mating Surface)

			35	M	98							
Series I	Series II	Series III										
09	08	A										
11	10	B		M								
				M								
13	12	C		M								
				M								
17	16	E		M								
				M								
19	18	F		M								
				M								

GJB599 Series Hermetically Sealed Electrical Connectors

[J599/24Y - C8 Panel Thickness 8mm Type Nut - Mounted Through - Wall Sealed Socket]

Shell Number														
Series I	Series II	Series III												
23	22	H	35	M		55	I		53	I		36	I	
			34	I		32	I		21	II		97	I	
			99	II										
25	24	J	35	M		61	I		29	I		19	I	
			24	I		43	I		04	I				

Power Contact Component Specifications



GJB599 Aerospace-Grade Electrical Connector

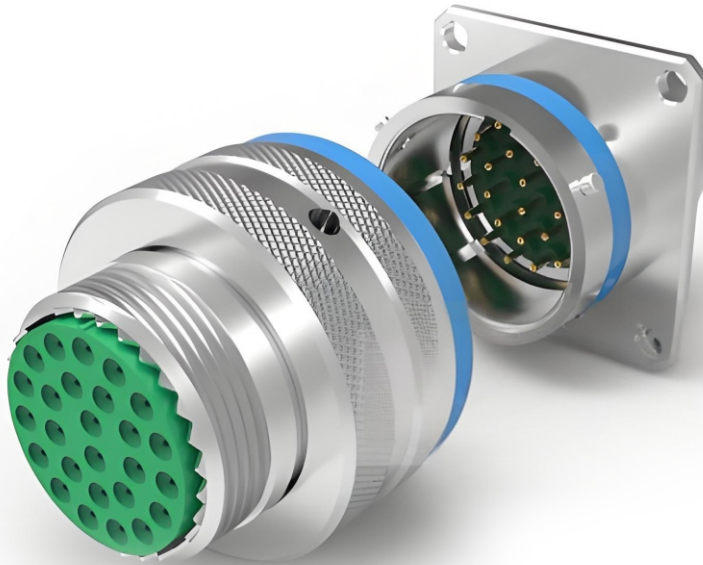

The pictures are for reference only

GJB599 Aerospace-Grade Electrical Connector

Space-Grade GJB599 Series | Circular Electrical Connector

Product Overview

- Complies with GJB 599 (MIL-DTL-38999) Series I
- Bayonet quick connection
- Small size, light weight
- High contact density
- EMI/RFI shielding
- Hermetic sealing at mating interface
- Anti-misplug design
- Widely used in aviation, aerospace and military systems
- Resistant to thermal vacuum
- Radiation-resistant



Main Performance

[Mechanical Performance]

- Shell: Aluminum alloy, stainless steel
- Plating:
 - Type F: Chemical nickel plating
 - Type E: Stainless steel passivation
- Insulator: Thermoset plastic
- Sealing body and seal: Rubber material

- Contacts: Beryllium copper gold-plated, crimp-removable
- Mechanical life: 500 cycles
- Vibration: Environmental temperature: Ambient; Frequency: 100~1000Hz; Power spectrum density: 5g²/Hz; Corresponding root mean square value: 9.5g
- Shock: 3ms half-sine wave; Acceleration peak value: 300g

[Electrical Performance]

Contact resistance and rated current of contacts:

Contact Specifications	Working Diameter (mm)	Contact Resistance (mΩ)	Rated Current (A)
22D	Φ0.76	≤12	5
20#	Φ1.00	≤5	7.5
16#	Φ1.60	≤2.5	13
12#	Φ2.40	≤1.5	23
10#	Φ3.15	≤1.0	40

Withstand voltage: V

Operating Class	M	N	I	II
Sea Level	1300	1000	1800	2300
21000m	800	600	1000	1000
30480m	800	600	1000	1000
30480m ~ 100000m	200	150	250	300

Electromagnetic shielding:

At 100MHz–1GHz, the minimum attenuation is 85dB; At 1GHz–10GHz, the minimum attenuation is 50dB

Note: Different contact arrangements correspond to different operating classes. For specific operating classes, please refer to the letter in the upper right corner of the contact arrangement.

[Environmental Performance]

- Operating temperature: -65°C to +200°C
- Salt spray resistance: Tested for 48h per Method 1001 of GJB1217
- Relative humidity: 40°C, up to 98%, lasting 48h
- The electrical connector also has good resistance to moisture, fog, mold, rain and dust

- Insulation resistance: Normal conditions: ≥5000MΩ Humid-heat conditions: ≥100MΩ
- Shell-to-shell continuity: Type F: ≤1.0mΩ
- Resistance to thermal vacuum: Weight loss of non-metallic materials: ≤1.0% Deposition of volatile condensates: ≤0.1%
- Radiation resistance: Irradiated by cobalt-60 γ-ray source, dose rate 0.5Gy/s, absorbed total dose: ≥5×10³Gy

GJB599 Aerospace-Grade Electrical Connector

Space-Grade GJB599 Series I Circular Electrical Connector

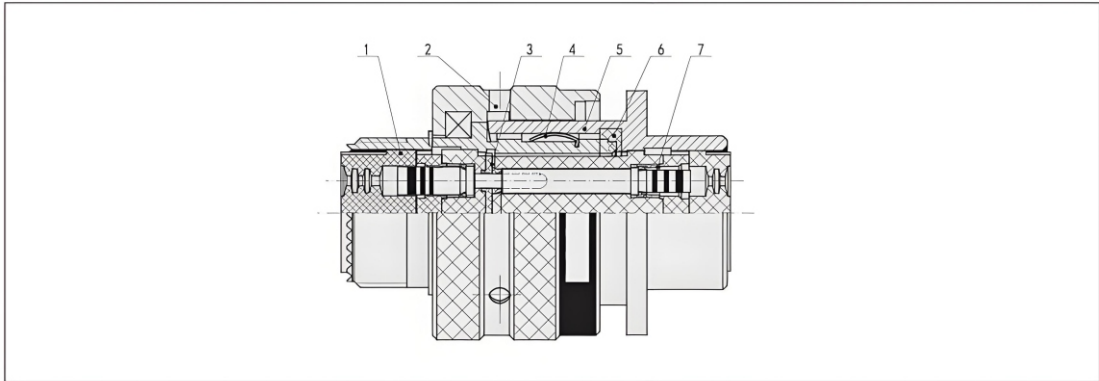

- The sealing body meets GJB599A for liquid immersion and low-pressure immersion resistance.
- Bayonet connection mechanism: Ensures quick connection and reliable anti-loosening performance.
- Interface sealing: Each contact is individually sealed.
- Shielding spring: Enables shell conduction before electrical contact, providing excellent EMI/RFI protection.
- Five-key shell positioning: Achieves blind mating and precise alignment of contacts.
- Sealing: Sealing is implemented around the insulator to ensure immersion resistance performance.
- Metal positioning sleeve: Ensures the reliability of contacts when installed inside the connector.

Model Naming

Series Main Name	JY	27467	G	17	F	35	P	N
Type	27467—Plug 27466—Wall-mount front-loading socket 27656—Wall-mount rear-loading socket 27468—Nut-mount socket							
Category	G—Space-grade; threaded tail for accessory installation							
Shell Number	09—11—13—15—17—19—21—23—25							
Shell Plating	F—Chemical nickel plating E—Stainless steel passivation							
Contact Arrangement	See GJB599 Series I Contact Arrangement Diagram							
Contact Type	Crimp type P—Pin S—Socket							
Key Position	N—Standard key position; A, B, C, D—Alternate key positions							

Note: In the model naming of national military standard GJB599 and U.S. military standard MIL-C-38999, all elements are identical except for the main designation. The main designation for GJB599 is "JY", while that for MIL-C-38999 is "MS"—the two are interoperable and interchangeable.

[Model Marking Example]

JY27467G17T35PN

This is a JY series plug; space-grade, with a threaded tail for accessory installation; 17# housing, housing plating is chemical nickel; 35 contacts, pin-type contacts, N key position.

The crimp contacts, shell key position, external dimensions and optional accessories are the same as those of GJB599 Series I electrical connectors.

GJB599 Aerospace-Grade Electrical Connector

Space-Grade GJB599 Series II Circular Electrical Connector

Product Overview

- Complies with GJB 599 (MIL-DTL-38999) Series II
- Bayonet quick connection
- Small size, light weight
- High contact density
- Optional EMI/RFI Shielding
- Hermetic sealing at mating interface
- Anti-misplug design
- Widely used in aviation, aerospace and military systems
- Resistant to thermal vacuum
- Radiation-resistant



Main Performance

[Mechanical Performance]

- Shell: Aluminum alloy, stainless steel
- Plating:
 - Type F: Chemical nickel plating
 - Type E: Stainless steel passivation
- Insulator: Thermoset plastic
- Sealing body and seal: Rubber material

- Contacts: Beryllium copper gold-plated, crimp-removable
- Mechanical life: 500 cycles
- Vibration:
 - Frequency: 100~1000Hz; Power spectral density: 1g²/Hz; Corresponding root mean square value: 41.7g
- Shock: 3ms half-sine wave; Acceleration peak value: 300g

[Electrical Performance]

Contact resistance and rated current of contacts:

Contact Specifications	Working Diameter (mm)	Contact Resistance (mΩ)	Rated Current (A)
22D	Φ0.76	≤12	5
20#	Φ1.00	≤5	7.5
16#	Φ1.60	≤2.5	13
12#	Φ2.40	≤1.5	23

Withstand voltage: V

Operating Class	M	N	I	II
Sea Level	1300	1000	1800	2300
21000m	800	600	1000	1000
30480m	800	600	1000	1000
30480m ~ 100000m	200	150	250	300

Electromagnetic shielding:

At 100MHz–1GHz, the minimum attenuation is 85dB; At 1GHz–10GHz, the minimum attenuation is 50dB

Note: Different contact arrangements correspond to different operating classes. For specific operating classes, please refer to the letter in the upper right corner of the contact arrangement.

[Environmental Performance]

- Operating temperature: -65°C to +200°C
- Salt spray resistance: Tested for 48h per Method 1001 of GJB1217
- Relative humidity: 40°C, up to 98%, lasting 48h
- The electrical connector also has good resistance to moisture, fog, mold, rain and dust

- Insulation resistance: Normal conditions: ≥5000MΩ Humid-heat conditions: ≥100MΩ
- Shell-to-shell continuity: Type F: ≤1.0mΩ
- Resistance to thermal vacuum: Weight loss of non-metallic materials: ≤1.0% Deposition of volatile condensates: ≤0.1%
- Radiation resistance: Irradiated by cobalt-60 γ-ray source, dose rate 0.5Gy/s, absorbed total dose: ≥5×10³Gy

GJB599 Aerospace-Grade Electrical Connector

Space-Grade GJB599 Series | Circular Electrical Connector

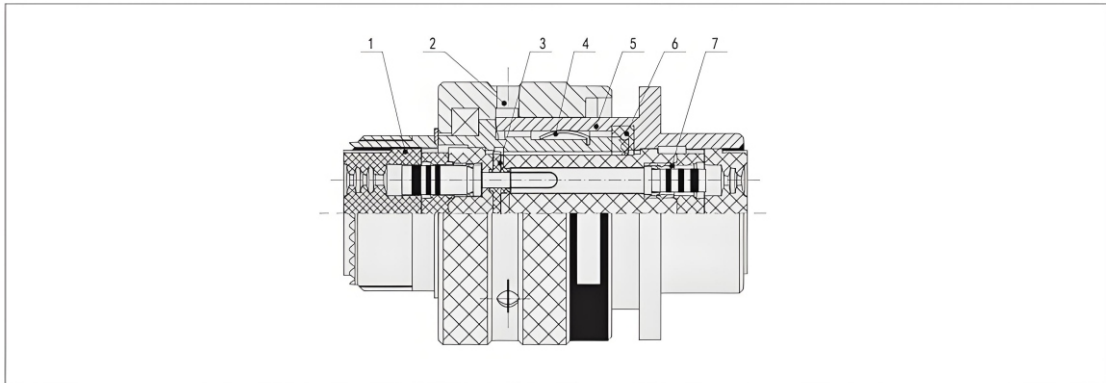

- The sealing body meets GJB599A for liquid immersion and low-pressure immersion resistance.
- Bayonet connection mechanism: Ensures quick connection and reliable anti-loosening performance.
- Interface sealing: Each contact is individually sealed.
- Shielding spring: Provides excellent EMI/RFI protection;
- Five-key shell positioning: Achieves blind mating and precise alignment of contacts.
- Sealing: Sealing is implemented around the insulator to ensure immersion resistance performance.
- Metal positioning sleeve: Ensures the reliability of contacts when installed inside the connector.

Model Naming

Series Main Name	JY	27473	G	17	F	35	P	N
Type	27473—Plug 27484—Shielded Plug 27474—Nut-Mount Socket 27472—Wall-Mount Front-Loading Socket 27497—Wall-Mount Rear-Loading Socket							
Category	G—Space-grade; threaded tail for accessory installation							
Shell Number	09—11—13—15—17—19—21—23—25							
Shell Plating	F—Space-grade, chemical nickel plating E—Stainless steel passivation							
Contact Arrangement	See GJB599 Series II Contact Arrangement Diagram							
Contact Type	Crimp type P—Pin S—Socket							
Key Position	N—Standard key position; A, B, C, D—Alternate key positions							

Note: In the model naming of national military standard GJB599 and U.S. military standard MIL-C-38999, all elements are identical except for the main designation. The main designation for GJB599 is "JY", while that for MIL-C-38999 is "MS"—the two are interoperable and interchangeable.

[Model Marking Example]

JY2476G717F35PN

This is a JY series plug, space-grade, with a threaded tail (for mounting rear accessories), 17# housing, housing plating of chemical nickel, 35 contacts, pin-type contacts, N key position.

The crimp contacts, shell key position, external dimensions and optional accessories are consistent with GJB599 Series II electrical connectors.

GJB599 Aerospace-Grade Electrical Connector

Space-Grade GJB599 Series III Circular Electrical Connector

Product Overview

- Compliant with GJB599 (MIL-DTL-38999) Series III
- Bayonet quick connection
- Small size, light weight
- High contact density
- EMI/RFI Shielding
- Hermetic sealing at mating interface
- Anti-misplug design
- Widely used in aviation, aerospace and military systems
- Resistant to thermal vacuum
- Radiation-resistant



Main Performance

[Mechanical Performance]

- Shell: Aluminum alloy, stainless steel
- Plating:
Type G: Chemical Nickel Plating
- Insulator: Thermoset plastic
- Sealing body and seal ring:
Silicone rubber material
- Contacts: Gold-plated copper alloy, crimp-type (removable)

[Electrical Performance]

Contact resistance and rated current of contacts:

Contact Specifications	Working Diameter (mm)	Contact Resistance (mΩ)	Rated Current (A)
22D	Φ0.76	≤12	5
20#	Φ1.00	≤5	7.5
16#	Φ1.60	≤2.5	13
12#	Φ2.40	≤1.5	23
10#	Φ3.15	≤1.0	40

Electromagnetic shielding:

At 100MHz–1GHz, the minimum attenuation is 85dB; At 1GHz–10GHz, the minimum attenuation is 50dB

[Environmental Performance]

- Operating temperature: -65°C to +200°C
- Salt spray resistance: Tested for 48h per Method 1001 of GJB1217
- Relative humidity: 40°C, up to 98%, lasting 48h
- The electrical connector also has good resistance to moisture, fog, mold, rain and dust

- Mechanical life: 500 cycles
- Vibration:
At high temperature: Frequency 100~1000Hz, power spectral density 1g²/Hz, corresponding RMS value 41.7g
At ambient temperature: Frequency 100~1000Hz, power spectral density 5g²/Hz, corresponding RMS value 49.5g
- Shock: 3ms half-sine wave, peak acceleration 300g

Withstand voltage: V

Operating Class	M	N	I	II
Sea Level	1300	1000	1800	2300
21000m	800	600	1000	1000
30480m	800	600	1000	1000
30480m ~ 100000m	200	150	250	300

Note: Different contact arrangements correspond to different operating classes. For specific operating classes, please refer to the letter in the upper right corner of the contact arrangement.

- Insulation resistance: Normal conditions: ≥5000MΩ Humid-heat conditions: ≥100MΩ
- Shell-to-shell continuity: Type F: ≤1.0mΩ
- Resistance to thermal vacuum: Weight loss of non-metallic materials: ≤1.0% Deposition of volatile condensates: ≤0.1%
- Radiation resistance: Irradiated by cobalt-60 γ-ray source, dose rate 0.5Gy/s, absorbed total dose: ≥5×10³Gy

GJB599 Aerospace-Grade Electrical Connector

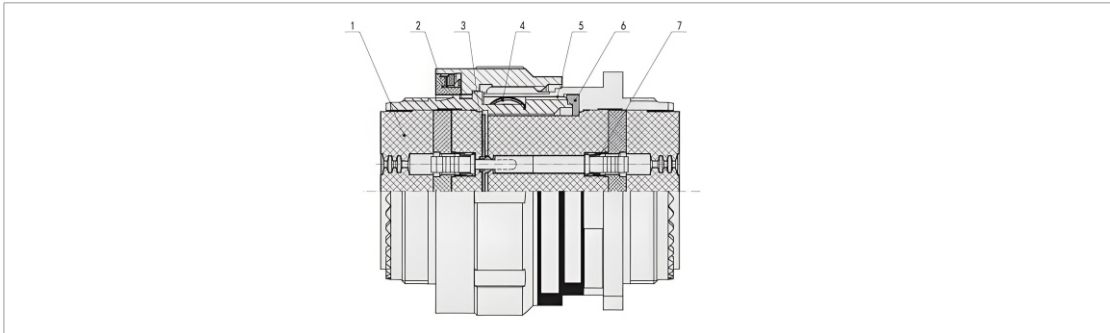

- The sealing body meets GJB599A for resistance to liquid immersion and low-pressure immersion.
- Anti-loosening mechanism: Ensures the ratio of mating force to unmating force is 1:2.
- Interface sealing: Each contact is individually sealed.
- Shielding spring: Enables shell conduction before electrical contact, providing excellent EMI/RFI protection.
- Five-key shell positioning: Achieves blind mating and precise alignment of contacts.
- Sealing: Sealing is implemented around the insulator to ensure immersion resistance performance.
- Metal positioning sleeve: Ensures the reliability of contacts when installed inside the connector.

Model Naming

Series Main Name	J599/	20	G	B	35	P	N
Type	20—Square-flange socket 24—Nut-locking socket 26—RFI-shielded plug						
Shell Plating	G—Space-grade, chemical nickel plating						
Shell Number	09 11 13 15 17 19 21 23 25 A to J A B C D E F G H J						
Contact Arrangement	See GJB599 Series I Contact Arrangement Diagram						
Contact Type	P—Pin S—Socket						
Key Position	N—Standard key position; A, B, C, D—Alternate key positions						

Note: In the model naming of national military standard GJB599 and U.S. military standard MIL-C-38999, all elements are identical except for the main designation. The main designation for GJB599 is "JY", while that for MIL-C-38999 is "MS"—the two are interoperable and interchangeable.

[Model Marking Example]

J599/20G235PN

This is a J599 series square-flange socket: the housing plating is space-grade chemical nickel, 23# housing, 35 contacts, pin-type contacts, N key position.

The crimp contacts, shell key position, external dimensions and optional accessories are consistent with GJB599 Series III electrical connectors.

